



www.vdo.it

Vehicle Electronics Catalog

Special OEM Solutions for Automotive, Industry and Marine

VDO



The Future of Mobility Starts with Today's Innovations

As a global supplier of mobile technologies, our passion for mobility strengthens everything we do. Mobility is about more than just effectiveness, it is the key driving force that allows us to reach new goals, make progress, and push beyond boundaries. The concept of mobility is at the core of our vision and reflected in everything we do.

Our employees around the globe are united by their common enthusiasm for modern vehicles and the opportunities that technology offers. The ability to embrace new ideas is just as important to us as experience and focused research and development. That's why experts from a wide range of fields work together within our company. Today, our innovative developments are proof of the success of this operational model.

Examples include our VDO products for a diverse range of special vehicles and machinery. These system solutions and individual components meet the most demanding requirements, yet at the same time offer maximum driving and working convenience.

Our catalog: always up-to-date

We want our Vehicle Electronics catalog to be a reliable companion that is always at your side to help you in your work. To ensure that, it is frequently updated. You will be kept informed of these updates by e-mail. This means you can always have the latest information available with just a few clicks – simply visit our extranet at <http://extranet.vdo.com>.

The process is simple.

If you already have extranet access

Access updates directly	Direct link on the Extranet Home Page or under the following link: Communications >> HQ Communications >> Marketing Communications >> Print >> Segment VE >> Catalog
-------------------------	--

If you do not yet have extranet access

Please register at	http://extranet.vdo.com and select Profile . Your access details will be sent to you immediately.
--------------------	--

To find updates, navigate to	above mentioned link
------------------------------	-----------------------------

Visit us at www.vdo.com

Visit www.vdo.com for all the latest news on our products and their innovative features, to find your nearest sales office, or for further information about the world of mobility.

For Italian Market visit www.it.vdo.com.

Sommario VDO

1. Instrumentation	10
1.1 Analog Instruments	10
1.1.1 Viewline instruments	11
1.1.2 International Cockpit	42
1.1.3 Customer-Specific Solutions	49
1.1.4 Modulcockpit II	50
1.2 Analog Clusters*	53
1.2.1 Centrobase 500	53
1.3 CAN Instruments*	55
1.3.1 CANcockpit*	56
1.3.2 Ocean Link	63
1.3.3 Accessories	66
1.3.4 Centrobase 350/400	67
1.3.5 FlexCluster	70
1.3.6 Display Controller MultiViu® Flex 7&4	72
2. Sensor and Switches	75
2.1 Speed and RPM Sensors	75
2.1.1 Blocking Oscillator Sensor	76
2.1.2 Inductive Sensor	78
2.1.3 Hall-Effect Sensor	80
2.1.4 Generator Sensor	81
2.1.5 Active Wheel Speed Sensor	82
2.2 Pressure Sensors	83
2.2.1 Pressure Sensor, Single-Pole, Common Ground	84
2.2.2 Pressure Sensor with Warning Contact, Common Ground	86
2.2.3 Pressure Sensor, Insulated Return	89
2.2.4 Pressure Sensor with Warning Contact (3 Connections)	91
2.3 Pressure Switches	93
2.3.1 Pressure Switch, Single-Pole, Common Ground	94
2.3.2 Pressure Sensor, Insulated Return	95

2.4 Temperature Sensors	96
2.4.1 Temperature Sensor, Single-Pole, Common Ground	97
2.4.2 Temperature Sensor, Dual-Pole, Insulated Return	98
2.4.3 Temperature Sensor with Warning Contact	101
2.4.4 Temperature Sensor for Air Temperature	103
2.4.5 Temperature Sensors (Special version)	104
2.4.6 Pyrometer Sensor	105
2.5 Temperature Switches	106
2.5.1 Temperature Switch, Single-Pole, Common Ground	107
2.5.2 Temperature Switch, Dual-Pole, Insulated Return	109
2.6 Liquid Level Switches	110
2.6.1 Liquid Level Switch, Linear Type, Oil/Diesel	111
2.6.2 Liquid Level Switch, Lever Type, Water	112
2.7 Customer-Specific Solutions Sensors for Engine Management Systems	113
2.7.1 Electronic Pressure Sensor (EPS)	114
2.7.2 Intake Air Pressure Sensors (MAP, T-MAP)	115
2.7.3 Mass airflow Sensor	116
2.7.4 Knock Sensor	117
2.7.5 Crankshaft Position Sensor	117
2.7.6 Camshaft Position Sensor	117
2.7.7 High Temperature Sensor (HTS)	118
2.8 Differential pressure sensor (2-port) for particulate filter	119
2.9 Inertial Sensor	121
2.10 UniNOx Sensor	124
3. Fuel and Water Management Systems	129
3.1 Fuel and Water Level Senders, Tubular Type	131
3.1.1 Tubular Fuel Level Sender, Metal, Standard	132
3.1.2 Fuel and Water Level Sensors, Stainless Steel	135
3.1.3 Tubular Fuel Level Sender, Metal, Robust	137
3.1.4 Tubular Fuel Level Sender, Plastic	139
3.2 Fuel Level Senders, Lever-Arm Type	141
3.2.1 Lever-Arm Fuel Level Sender, Plastic	142
3.2.2 Adjustable Lever-Arm Fuel Level Sender, Standard/ALAS I	145
3.2.3 Adjustable Lever-Arm Fuel Level Sender, ALAS II	150

3.3 Water Level Sensors	152
3.3.1 Fresh Water Level Sensors	153
3.3.2 Black Water Level Sensors	154
4. Control Systems	155
4.1 Pedal Interface II	156
4.2 AGB III	159
4.3 E-Gas® Compact	160
4.4 Actuators	163
4.5 KIBES (Key to Integrated OnBoard Electronic Systems)	166
5. Accelerator Pedals	170
5.1 Pedals	170
5.1.1 Floor-Mounted Pedal	171
5.1.2 Suspended Pedal	181
5.1.3 Customer-Specific Solutions	188
5.2 Hand-Operated Accelerators and Pedal Sensors	190
6. Screen Washer Systems	193
7. Customer-Specific Solutions	196
7.1 Control Units and Electronic Network Solutions (ENS)	197
7.2 Custom Solutions	198
7.2.1 Panel Design and Build*	198
8. Radio and speakers	199
8.1 Radio	199
8.2 Loudspeakers	204
8.3 Accessories	207
9. Rearview systems	208
9.1 Standard Line	209
9.2 Pro Line	212
10. Product Solutions and Applications	218

Flexible product solutions for diverse applications

We offer standard components, flexible systems, and customized solutions for on-highway and off-highway vehicles, stationary machinery, sports vehicles, and leisure boats.

On-highway

We develop comprehensive systems technology for commercial vehicles approved for highway use. Our portfolio focuses on products for heavy plant and special vehicles, including municipal vehicles, mobile cranes, buses, and other types of commercial vehicle. We offer tailored solutions to suit every type of vehicle, usage profile, and manufacturer requirement

Off-highway

Our systems for the various types of special off-highway vehicles are developed in close cooperation with engineering and production specialists. We offer proven systems, including audio equipment, for machinery, cranes, and special vehicles used in areas like forestry, agriculture, and aviation.

Leisure vehicles

Tuning companies and car manufacturers who primarily produce hand-finished vehicles in small production runs often have highly specialized requirements, especially when it comes to instrumentation. Many years of experience and a high degree of flexibility make us the ideal partner for anyone seeking custom solutions for these kinds of vehicles.

Leisure boats

We supply shipyards and boat manufacturers with reliable, accurate instruments for navigation, engine monitoring, and onboard electrical system monitoring. Our product range for motorboats and sailing yachts is based on our extensive expertise as a supplier to the boatbuilding industry.

Engines and stationary machinery

We also develop sensor, control, and instrumentation technology for machines and other equipment, such as generators and compressors, that are powered by an engine but used solely in stationary applications. By utilizing systems that are already in large-scale production, we are able to offer highly cost-effective solutions.



Applications

Special OEM Solutions for

On-highway

Systems technology for commercial vehicles approved for road use

- _ Trucks
- _ Mobile cranes
- _ Buses
- _ Specialist vehicles, e.g., fire trucks



Off-highway

Rugged solutions for tough conditions

- _ Construction vehicles
- _ Agricultural and forestry vehicles
- _ Industrial trucks
- _ All types of special vehicles, e.g., for airports



Engines/stationary machinery

Sensor, control, and instrumentation technology for stationary machinery, e.g.:

- _ Generators
- _ Compressors
- _ Engine-powered equipment
- _ Engines
- _ Transmissions



Leisure vehicles

Custom short-run solutions for the leisure and sports sectors, e.g.:

- _ Sports vehicles (power quads, jet skis, snowmobiles, etc.)
- _ Motorcycles
- _ Tuned vehicles



Leisure boats

Ocean-going instrumentation, engine components for boatbuilders

- _ Motor yachts
- _ Sailing boats
- _ Boat engines





1. Instrumentation

1.1 Analog Instruments

1.2 Analog Cluster

1.3 Can Instruments



1.1.1 Viewline instruments

Viewline is our new standardized instrument platform for special vehicles and machinery from various sectors. With modular solutions in three housing variants, we offer more features, more flexible installation, and a wide variety of design options. Our space-saving multifunction and combi-instruments are unique in this sector. In addition, Viewline offers designers maximum freedom when laying out the cockpit and represents impressive value.

Built for the toughest jobs

As a technology leader, we are familiar with the complex product requirements of manufacturers of specialist vehicles for industry, construction, forestry, and agriculture. Our product range is tailored to meet these requirements, enabling us to offer fully customized, reliable solutions. Maximum precision and the integration of pioneering technologies are just as important to us as ease of use and stylish design. The latest outcome of our research and development program is Viewline - an innovative and comprehensive standard instru-

mentation platform that will replace the existing product series. A whole host of instrumentation variants are possible thanks to the flexibility offered by a range of housing sizes.



Harmony in function and design

Our plug and play design concept for panel and flush mounting means that Viewline instruments offer maximum flexibility when it comes to installation. With or without bezel, the modular concept allows for a high degree of design variation. Uniquely for this sector, every solution features full backlight technology.

The Viewline platform now incorporates a generic display concept that allows a huge variety of sensor signals to be processed and displayed. Viewline is a forward-looking instrumentation concept that guarantees quality and flexibility and offers greater design freedom and diversity.

Long-term benefits with new technologies

During development of the Viewline instrumentation range, our focus lied firmly on the requirements of manufacturers. The result is a cross-platform standard that offers maximum freedom in cockpit design.

Certified quality and innovative technology

Viewline is a comprehensive range of state-of-the-art modular instruments for engine monitoring. Featuring more functions and greater flexibility in terms of installation and design, Viewline increases the scope for creative cockpit design. High quality workmanship and engineering excellence allow for outstanding reliability and readability.

Flush or panel mounting

All Viewline instruments can be conveniently inserted in the instrument panel from behind. It is possible to install the instruments with modular bezels or to integrate them flush with the panel without a bezel. This allows high flexibility for cockpit customization and creates opportunities for numerous design variants.

Simple to switch

The far-sighted flexibility of the Viewline design concept makes a high degree of installation freedom. This makes switching or upgrading to Viewline always a smooth and straightforward process. We offer a reliable, advanced solution for instruments in this range. As an experienced and trusted partner to leading manufacturers of special vehicles and machinery, we are on hand right from the planning stage to enable seamless integration and optimum utilization of all Viewline benefits.



Anti-fog, water resistant

Electrical devices designed for special vehicles and machinery used under extreme conditions need to be carefully protected. That is why every Viewline instrument casing is made from corrosion-proof materials and has a front face that is hermetically sealed in compliance with the IP 67 standard. Anti-fog double lenses in shock-resistant plastic are also available on request. Irritating reflections are practically eliminated and water resistance is increased. The domed construction also makes possible that rainwater flows off quickly even when instruments are mounted horizontally.



LED illumination and warning lights

Viewline instruments are fitted with highly visible, high intensity LED warning lights. These ensure that critical operating states can be quickly and safely move detected before quickly. In the case of multifunctional speedometers and rev counters, the Viewline platform allows instruments to be equipped with up to five warning lights. All Viewline instruments feature LED illumination for the LCD display, dial face, and needle.

Clip-on bezels

The modular bezel concept offers true design flexibility in the layout of instrument panels. The three attractive designs in black, white or chrome are suitable for every machinery instrument panel or special vehicle cockpit. The range also includes bezels with flat, round, and triangular profiles. Each of the bezel designs is compatible with every Viewline product.



Cutaway showing double lens



Highly visible LED warning lights



Bezels: choice of color and design

Liquid crystal display

In addition to an analog needle showing speed or engine revs, the new Viewline speedometer and rev counter instruments also feature an additional digital display.

- Display size 37 x 11 mm.
- Quick, reliable access to additional data.
- Optimized reading angle and display layout.
- Displays for speed or engine revs.
- Additional monitoring functions available on LCD.
- Individual function selection via external control button.

Full backlight technology

All Viewline instruments benefit from fully backlit dial faces and needles.

- Optimum contrast and superb readability of the display when lit.
- Attractive display at night thanks to clear dial face design.

Signal inputs

Viewline supports the following signal inputs:

- Standard speedometer and rev counter signals.
- Second frequency input (optional).
- Standard signals for engine monitoring and onboard electrical system.
- Signal inputs for special senders.
- Up to five switching inputs for warning lights (optional).

Programmable displays

Viewline gives users a choice of different settings and programming options:

- Basic setup via dip switches, internal/external button or PC software.
- Various configurable display functions.

Our range of instrumentation is dedicated to engines, machines and special vehicles

Our technology leadership brings us to be confronted to the complexity and the variety of requirements of special vehicles manufacturers in the industry, forestry, agriculture, construction, the motor racing competition and tuning. Our product gamut responds to these requirements. The accuracy and the employment of innovative technologies are also important for us as well as the usability and appealing design of our products.

VIEWLINE: standard range

An adapted solution to every application on the market and configurable.

Viewline 600 references are available in standard version for all applications: complete dashboards, to

modernize a facility, for navigation, route and extreme environments.

There are 2 types of packaging: blister and carton box of 10 pcs.



Bezels Viewline

Blister packaging, adapted for distribution, which includes:

- The instrument.
- Bezel.
- The clamping ring.
- Installation instructions.
- Buttons (for tachometer and speedometer).
- The cable harness with connector (30 cm).
- Industrial cardboard version 10 (single instrument) with or without strapping.



Packaging	Part number	Dial color	Operating voltage	Dial scale	Outer scale	Outer scale Max	Bezel shape	Bezel color	Input signal
-----------	-------------	------------	-------------------	------------	-------------	-----------------	-------------	-------------	--------------

Ø 52 MM

Tachometer



Blister	A2C59512322	black	12/24 V	single	0 rpm	4000 rpm	triangle	black	terminal W, Inductive, Generator, Hall effect, terminal 1
Blister	A2C59512323	black	12/24 V	single	0 rpm	6000 rpm	triangle	black	terminal W, Inductive, Generator, Hall effect, terminal 1
Blister	A2C59512324	black	12/24 V	single	0 rpm	8000 rpm	triangle	black	terminal W, Inductive, Generator, Hall effect, terminal 1
Blister	A2C59512325	white	12/24 V	single	0 rpm	4000 rpm	triangle	chrome	terminal W, Inductive, Generator, Hall effect, terminal 1
Blister	A2C59512326	white	12/24 V	single	0 rpm	6000 rpm	triangle	chrome	terminal W, Inductive, Generator, Hall effect, terminal 1
Blister	A2C59512327	white	12/24 V	single	0 rpm	8000 rpm	triangle	chrome	terminal W, Inductive, Generator, Hall effect, terminal 1
Blister	A2C59512344	black	12/24 V	single	0 rpm	4000 rpm	round	black	terminal W, Inductive, Generator, Hall effect, terminal 1
Blister	A2C59512345	black	12/24 V	single	0 rpm	6000 rpm	round	black	terminal W, Inductive, Generator, Hall effect, terminal 1
Blister	A2C59512346	black	12/24 V	single	0 rpm	8000 rpm	round	black	terminal W, Inductive, Generator, Hall effect, terminal 1
Blister	A2C59512347	white	12/24 V	single	0 rpm	4000 rpm	round	white	terminal W, Inductive, Generator, Hall effect, terminal 1
Blister	A2C59512348	white	12/24 V	single	0 rpm	6000 rpm	round	white	terminal W, Inductive, Generator, Hall effect, terminal 1
Blister	A2C59512349	white	12/24 V	single	0 rpm	8000 rpm	round	white	terminal W, Inductive, Generator, Hall effect, terminal 1
10 pcs	A2C59510038	black	12/24 V	single	0 rpm	4000 rpm	no bezel	no bezel	terminal W, Inductive, Generator, Hall effect, terminal 1
10 pcs	A2C59510039	black	12/24 V	single	0 rpm	6000 rpm	no bezel	no bezel	terminal W, Inductive, Generator, Hall effect, terminal 1
10 pcs	A2C59510040	black	12/24 V	single	0 rpm	8000 rpm	no bezel	no bezel	terminal W, Inductive, Generator, Hall effect, terminal 1
10 pcs	A2C59510041	white	12/24 V	single	0 rpm	4000 rpm	no bezel	no bezel	terminal W, Inductive, Generator, Hall effect, terminal 1
10 pcs	A2C59510042	white	12/24 V	single	0 rpm	6000 rpm	no bezel	no bezel	terminal W, Inductive, Generator, Hall effect, terminal 1
10 pcs	A2C59510043	white	12/24 V	single	0 rpm	8000 rpm	no bezel	no bezel	terminal W, Inductive, Generator, Hall effect, terminal 1

Ammeter



Blister	A2C59512306	black	12/24 V	single	-30 A	+30 A	triangle	black	60 mV
Blister	A2C59512307	black	12/24 V	single	-60 A	+60 A	triangle	black	60 mV
Blister	A2C59512308	black	12/24 V	single	-100 A	+100 A	triangle	black	60 mV
Blister	A2C59512309	black	12/24 V	single	-150 A	+150 A	triangle	black	60 mV
Blister	A2C59512310	white	12/24 V	single	-30 A	+30 A	triangle	chrome	60 mV
Blister	A2C59512311	white	12/24 V	single	-60 A	+60 A	triangle	chrome	60 mV
Blister	A2C59512312	white	12/24 V	single	-100 A	+100 A	triangle	chrome	60 mV
Blister	A2C59512313	white	12/24 V	single	-150 A	+150 A	triangle	chrome	60 mV
Blister	A2C59512328	black	12/24 V	single	-60 A	+60 A	round	black	60 mV
Blister	A2C59512329	black	12/24 V	single	-150 A	+150 A	round	black	60 mV
Blister	A2C59512330	white	12/24 V	single	-60 A	+60 A	round	white	60 mV
10 pcs	A2C59510000	black	12/24 V	single	-30 A	+30 A	no bezel	no bezel	60 mV
10 pcs	A2C59510002	black	12/24 V	single	-100 A	+100 A	no bezel	no bezel	60 mV
10 pcs	A2C59510004	white	12/24 V	single	-30 A	+30 A	no bezel	no bezel	60 mV
10 pcs	A2C59510006	white	12/24 V	single	-100 A	+100 A	no bezel	no bezel	60 mV
10 pcs	A2C59510022	black	12/24 V	single	-60 A	+60 A	no bezel	no bezel	60 mV
10 pcs	A2C59510023	black	12/24 V	single	-150 A	+150 A	no bezel	no bezel	60 mV
10 pcs	A2C59510024	white	12/24 V	single	-60 A	+60 A	no bezel	no bezel	60 mV
10 pcs	A2C59510025	white	12/24 V	single	-150 A	+150 A	no bezel	no bezel	60 mV

Engine running hours meter

Packaging	Part number	Dial color	Operating voltage	Dial scale	Outer scale	Outer scale Max	Inner scale	Inner scale	Bezel shape	Bezel color	Input signal
-----------	-------------	------------	-------------------	------------	-------------	-----------------	-------------	-------------	-------------	-------------	--------------

Ø 52 MM

Hour counters



Blister	A2C59512448	black	12/24 V	triangle	chrome						
Blister	A2C59512449	white	12/24 V	triangle	chrome						
Blister	A2C59512451	white	12/24 V	triangle	chrome						
Blister	A2C59512452	black	12/24 V	triangle	chrome						
Blister	A2C59512453	black	12/24 V	round	black						
Blister	A2C59512454	white	12/24 V	round	white						
Blister	A2C59512653	black	12/24 V	triangle	black						
Blister	A2C59512654	black	12/24 V	triangle	black						
10 pcs	A2C59510872	black	12/24 V	no bezel	no bezel						
10 pcs	A2C59510873	white	12/24 V	no bezel	no bezel						
10 pcs	A2C59510876	black	12/24 V	no bezel	no bezel						
10 pcs	A2C59510877	white	12/24 V	no bezel	no bezel						

Engine oil pressure



Blister	A2C59514107	black	12/24 V	double	0 psi	100 psi	0 bar	7 bar	round	black	240-33,5 Ω
Blister	A2C59514108	black	12/24 V	double	0 psi	100 psi	0 bar	7 bar	triangle	chrome	240-33,5 Ω
Blister	A2C59514109	black	12/24 V	double	0 psi	100 psi	0 bar	7 bar	triangle	black	240-33,5 Ω
Blister	A2C59514110	black	12/24 V	single	0 psi	100 psi	-	-	triangle	black	240-33,5 Ω
Blister	A2C59514111	black	12/24 V	double	0 bar	10 bar	0 psi	150 psi	round	black	10-184 Ω
Blister	A2C59514112	black	12/24 V	double	0 bar	10 bar	0 psi	150 psi	triangle	chrome	10-184 Ω
Blister	A2C59514113	black	12/24 V	double	0 bar	10 bar	0 psi	150 psi	triangle	black	10-184 Ω
Blister	A2C59514114	black	12/24 V	single	0 bar	10 bar	-	-	triangle	black	10-184 Ω
Blister	A2C59514115	black	12/24 V	single	0 kPa	10 kPa x100	-	-	triangle	black	10-184 Ω
Blister	A2C59514117	black	12/24 V	double	0 psi	150 psi	0 bar	10 bar	triangle	black	10-184 Ω
Blister	A2C59514118	black	12/24 V	double	0 psi	150 psi	0 bar	10 bar	round	black	240-33,5 Ω
Blister	A2C59514119	black	12/24 V	double	0 psi	150 psi	0 bar	10 bar	triangle	chrome	240-33,5 Ω
Blister	A2C59514120	black	12/24 V	double	0 psi	150 psi	0 bar	10 bar	triangle	black	240-33,5 Ω
Blister	A2C59514121	black	12/24 V	single	0 psi	150 psi	-	-	triangle	black	10-184 Ω
Blister	A2C59514122	black	12/24 V	single	0 psi	150 psi	-	-	triangle	black	240-33,5 Ω
Blister	A2C59514123	black	12/24 V	double	0 bar	5 bar	0 psi	80 psi	round	black	10-184 Ω
Blister	A2C59514124	black	12/24 V	double	0 bar	5 bar	0 psi	80 psi	triangle	chrome	10-184 Ω
Blister	A2C59514125	black	12/24 V	double	0 bar	5 bar	0 psi	80 psi	triangle	black	10-184 Ω
Blister	A2C59514126	black	12/24 V	single	0 bar	5 bar	-	-	triangle	black	10-184 Ω
Blister	A2C59514127	black	12/24 V	single	0 kPa	5 kpa	-	-	triangle	black	10-184 Ω
Blister	A2C59514128	black	12/24 V	double	0 psi	80 psi	0 bar	5 bar	round	black	10-184 Ω
Blister	A2C59514129	black	12/24 V	double	0 psi	80 psi	0 bar	5 bar	triangle	chrome	10-184 Ω
Blister	A2C59514130	black	12/24 V	double	0 psi	80 psi	0 bar	5 bar	triangle	black	10-184 Ω
Blister	A2C59514132	black	12/24 V	double	0 psi	80 psi	0 bar	5 bar	triangle	black	240-33,5 Ω
Blister	A2C59514134	black	12/24 V	single	0 psi	80 psi	-	-	triangle	black	10-184 Ω
Blister	A2C59514135	black	12/24 V	single	0 psi	80 psi	-	-	triangle	black	240-33,5 Ω

Packaging	Part number	Dial color	Operating voltage	Dial scale	Outer scale	Outer scale Max	Inner scale	Inner scale	Bezel shape	Bezel color	Input signal
Blister	A2C59514196	white	12/24 V	double	0 psi	100 psi	0 bar	7 bar	round	white	240-33,5 Ω
Blister	A2C59514197	white	12/24 V	double	0 psi	100 psi	0 bar	7 bar	triangle	chrome	240-33,5 Ω
Blister	A2C59514199	white	12/24 V	double	0 bar	10 bar	0 psi	150 psi	round	white	10-184 Ω
Blister	A2C59514200	white	12/24 V	double	0 bar	10 bar	0 psi	150 psi	triangle	chrome	10-184 Ω
Blister	A2C59514201	white	12/24 V	single	0 bar	10 bar	-	-	triangle	chrome	10-184 Ω
Blister	A2C59514202	white	12/24 V	double	0 psi	150 psi	0 bar	10 bar	round	white	10-184 Ω
Blister	A2C59514203	white	12/24 V	double	0 psi	150 psi	0 bar	10 bar	triangle	chrome	10-184 Ω
Blister	A2C59514204	white	12/24 V	double	0 psi	150 psi	0 bar	10 bar	round	white	240-33,5 Ω
Blister	A2C59514205	white	12/24 V	double	0 psi	150 psi	0 bar	10 bar	triangle	chrome	240-33,5 Ω
Blister	A2C59514206	white	12/24 V	double	0 bar	25 bar	0 psi	350 psi	round	white	10-184 Ω
Blister	A2C59514207	white	12/24 V	double	0 bar	25 bar	0 psi	350 psi	triangle	chrome	10-184 Ω
Blister	A2C59514208	white	12/24 V	double	0 bar	30 bar	0 psi	435 psi	round	white	10-184 Ω
Blister	A2C59514209	white	12/24 V	double	0 bar	30 bar	0 psi	435 psi	triangle	chrome	10-184 Ω
Blister	A2C59514211	white	12/24 V	double	0 bar	5 bar	0 psi	80 psi	round	white	10-184 Ω
Blister	A2C59514212	white	12/24 V	double	0 bar	5 bar	0 psi	80 psi	triangle	chrome	10-184 Ω
Blister	A2C59514213	white	12/24 V	single	0 bar	5 bar	-	-	triangle	chrome	10-184 Ω
Blister	A2C59514214	white	12/24 V	double	0 psi	80 psi	0 bar	5 bar	round	white	10-184 Ω
Blister	A2C59514215	white	12/24 V	double	0 psi	80 psi	0 bar	5 bar	triangle	chrome	10-184 Ω
Blister	A2C59514216	white	12/24 V	double	0 psi	80 psi	0 bar	5 bar	round	white	240-33,5 Ω
Blister	A2C59514217	white	12/24 V	double	0 psi	80 psi	0 bar	5 bar	triangle	chrome	240-33,5 Ω
Blister	A2C59514218	white	12/24 V	single	0 psi	80 psi	-	-	triangle	chrome	10-184 Ω
10 pcs	A2C60000967	black	12/24 V	single	0 bar	5 bar	-	-	no bezel	no bezel	10-184 Ω
10 pcs	A2C60000968	black	12/24 V	single	0 bar	10 bar	-	-	no bezel	no bezel	10-184 Ω
10 pcs	A2C60000972	black	12/24 V	single	0 psi	80 psi	-	-	no bezel	no bezel	10-184 Ω
10 pcs	A2C60000973	black	12/24 V	single	0 psi	80 psi	-	-	no bezel	no bezel	240-33,5 Ω
10 pcs	A2C60000974	black	12/24 V	single	0 psi	100 psi	-	-	no bezel	no bezel	240-33,5 Ω
10 pcs	A2C60000976	black	12/24 V	single	0 psi	150 psi	-	-	no bezel	no bezel	240-33,5 Ω
10 pcs	A2C60000977	black	12/24 V	single	0 psi	150 psi	-	-	no bezel	no bezel	10-184 Ω
10 pcs	A2C60000980	black	12/24 V	single	0 kPa	5 kpa	-	-	no bezel	no bezel	10-184 Ω
10 pcs	A2C60000981	black	12/24 V	single	0 kPa	10 kPa x100	-	-	no bezel	no bezel	10-184 Ω
10 pcs	A2C60000983	black	12/24 V	double	0 psi	80 psi	0 bar	5 bar	no bezel	no bezel	240-33,5 Ω
10 pcs	A2C60000984	white	12/24 V	single	0 bar	5 bar	-	-	no bezel	no bezel	10-184 Ω
10 pcs	A2C60000985	white	12/24 V	single	0 bar	10 bar	-	-	no bezel	no bezel	10-184 Ω
10 pcs	A2C60000990	white	12/24 V	single	0 psi	80 psi	-	-	no bezel	no bezel	10-184 Ω
10 pcs	A2C60001024	black	12/24 V	double	0 bar	5 bar	0 psi	80 psi	no bezel	no bezel	10-184 Ω
10 pcs	A2C60001025	black	12/24 V	double	0 bar	10 bar	0 psi	150 psi	no bezel	no bezel	10-184 Ω
10 pcs	A2C60001028	black	12/24 V	double	0 psi	80 psi	0 bar	5 bar	no bezel	no bezel	10-184 Ω
10 pcs	A2C60001029	black	12/24 V	double	0 psi	100 psi	0 bar	7 bar	no bezel	no bezel	240-33,5 Ω
10 pcs	A2C60001030	black	12/24 V	double	0 psi	150 psi	0 bar	10 bar	no bezel	no bezel	240-33,5 Ω
10 pcs	A2C60001031	black	12/24 V	double	0 psi	150 psi	0 bar	10 bar	no bezel	no bezel	10-184 Ω
10 pcs	A2C60001035	white	12/24 V	double	0 bar	5 bar	0 psi	80 psi	no bezel	no bezel	10-184 Ω
10 pcs	A2C60001036	white	12/24 V	double	0 bar	10 bar	0 psi	150 psi	no bezel	no bezel	10-184 Ω
10 pcs	A2C60001037	white	12/24 V	double	0 bar	25 bar	0 psi	350 psi	no bezel	no bezel	10-184 Ω
10 pcs	A2C60001038	white	12/24 V	double	0 bar	30 bar	0 psi	435 psi	no bezel	no bezel	10-184 Ω
10 pcs	A2C60001039	white	12/24 V	double	0 psi	80 psi	0 bar	5 bar	no bezel	no bezel	240-33,5 Ω
10 pcs	A2C60001044	white	12/24 V	double	0 psi	80 psi	0 bar	5 bar	no bezel	no bezel	10-184 Ω
10 pcs	A2C60001045	white	12/24 V	double	0 psi	100 psi	0 bar	7 bar	no bezel	no bezel	240-33,5 Ω
10 pcs	A2C60001046	white	12/24 V	double	0 psi	150 psi	0 bar	10 bar	no bezel	no bezel	240-33,5 Ω
10 pcs	A2C60001047	white	12/24 V	double	0 psi	150 psi	0 bar	10 bar	no bezel	no bezel	10-184 Ω

Packaging	Part number	Dial color	Operating voltage	Dial scale	Outer scale	Outer scale Max	Inner scale	Inner scale	Bezel shape	Bezel color	Input signal
-----------	-------------	------------	-------------------	------------	-------------	-----------------	-------------	-------------	-------------	-------------	--------------

Ø 52 MM

Gearbox pressure



Blister	A2C59514136	black	12/24 V	double	0 bar	25 bar	0 psi	350 psi	round	black	10-184 Ω
Blister	A2C59514137	black	12/24 V	double	0 bar	25 bar	0 psi	350 psi	triangle	chrome	10-184 Ω
Blister	A2C59514138	black	12/24 V	double	0 bar	25 bar	0 psi	350 psi	triangle	black	10-184 Ω
Blister	A2C59514139	black	12/24 V	single	0 bar	25 bar	-	-	triangle	black	10-184 Ω
Blister	A2C59514140	black	12/24 V	single	0 kPa	25 kpa	-	-	triangle	black	10-184 Ω
Blister	A2C59514141	black	12/24 V	double	0 bar	30 bar	0 psi	435 psi	round	black	10-184 Ω
Blister	A2C59514142	black	12/24 V	double	0 bar	30 bar	0 psi	435 psi	triangle	chrome	10-184 Ω
Blister	A2C59514143	black	12/24 V	double	0 bar	30 bar	0 psi	435 psi	triangle	black	10-184 Ω
Blister	A2C59514144	black	12/24 V	double	0 psi	350 psi	0 kPa	25 kPa	triangle	black	10-184 Ω
Blister	A2C59514145	black	12/24 V	double	0 psi	400 psi	0 bar	25 bar	round	black	10-184 Ω
Blister	A2C59514146	black	12/24 V	double	0 psi	400 psi	0 bar	25 bar	triangle	chrome	10-184 Ω
Blister	A2C59514147	black	12/24 V	double	0 psi	400 psi	0 bar	25 bar	triangle	black	10-184 Ω
Blister	A2C59514148	black	12/24 V	single	0 psi	400 psi	-	-	triangle	black	10-184 Ω
Blister	A2C59514219	white	12/24 V	single	0 bar	25 bar	-	-	triangle	chrome	10-184 Ω
Blister	A2C59514220	white	12/24 V	double	0 psi	350 psi	0 bar	25 bar	round	white	10-184 Ω
Blister	A2C59514221	white	12/24 V	double	0 psi	350 psi	0 bar	25 bar	triangle	chrome	10-184 Ω
Blister	A2C59514222	white	12/24 V	single	0 psi	350 psi	-	-	triangle	chrome	10-184 Ω
Blister	A2C59514223	white	12/24 V	double	0 psi	400 psi	0 bar	25 bar	round	white	10-184 Ω
Blister	A2C59514224	white	12/24 V	double	0 psi	400 psi	0 bar	25 bar	triangle	chrome	10-184 Ω
10 pcs	A2C60000970	black	12/24 V	single	0 bar	25 bar	-	-	no bezel	no bezel	10-184 Ω
10 pcs	A2C60000979	black	12/24 V	single	0 psi	400 psi	-	-	no bezel	no bezel	10-184 Ω
10 pcs	A2C60000982	black	12/24 V	single	0 kPa	25 kpa	-	-	no bezel	no bezel	10-184 Ω
10 pcs	A2C60000987	white	12/24 V	single	0 bar	25 bar	-	-	no bezel	no bezel	10-184 Ω
10 pcs	A2C60000993	white	12/24 V	single	0 psi	350 psi	-	-	no bezel	no bezel	10-184 Ω
10 pcs	A2C60001000	black	12/24 V	double	0 psi	350 psi	0 kPa	25 kPa	no bezel	no bezel	10-184 Ω
10 pcs	A2C60001026	black	12/24 V	double	0 bar	25 bar	0 psi	350 psi	no bezel	no bezel	10-184 Ω
10 pcs	A2C60001027	black	12/24 V	double	0 bar	30 bar	0 psi	435 psi	no bezel	no bezel	10-184 Ω
10 pcs	A2C60001032	black	12/24 V	double	0 psi	400 psi	0 bar	25 bar	no bezel	no bezel	10-184 Ω
10 pcs	A2C60001048	white	12/24 V	double	0 psi	350 psi	0 bar	25 bar	no bezel	no bezel	10-184 Ω
10 pcs	A2C60001049	white	12/24 V	double	0 psi	400 psi	0 bar	25 bar	no bezel	no bezel	10-184 Ω

Packaging	Part number	Dial color	Operating voltage	Dial scale	Outer scale	Outer scale Max	Inner scale	Inner scale	Bezel shape	Bezel color	Input signal
-----------	-------------	------------	-------------------	------------	-------------	-----------------	-------------	-------------	-------------	-------------	--------------

Ø 52 MM

Turbo pressure



Blister	A2C59514149	black	12/24 V	double	0 bar	2 bar	0 psi	28 psi	round	black	10-184 Ω
Blister	A2C59514150	black	12/24 V	double	0 bar	2 bar	0 psi	28 psi	triangle	chrome	10-184 Ω
Blister	A2C59514151	black	12/24 V	double	0 bar	2 bar	0 psi	28 psi	triangle	black	10-184 Ω
Blister	A2C59514152	black	12/24 V	single	0 bar	2 bar	-	-	triangle	black	10-184 Ω
Blister	A2C59514153	black	12/24 V	single	0 psi	30 psi	-	-	triangle	black	10-184 Ω
Blister	A2C59514225	white	12/24 V	double	0 bar	2 bar	0 psi	28 psi	round	white	10-184 Ω
Blister	A2C59514226	white	12/24 V	double	0 bar	2 bar	0 psi	28 psi	triangle	chrome	10-184 Ω
Blister	A2C59514227	white	12/24 V	single	0 bar	2 bar	-	-	round	white	10-184 Ω
Blister	A2C59514228	white	12/24 V	single	0 bar	2 bar	-	-	triangle	chrome	10-184 Ω
Blister	A2C59514229	white	12/24 V	single	0 psi	80 psi	-	-	triangle	chrome	10-184 Ω
10 pcs	A2C60000966	black	12/24 V	single	0 bar	2 bar	-	-	no bezel	no bezel	10-184 Ω
10 pcs	A2C60000971	black	12/24 V	single	0 psi	30 psi	-	-	no bezel	no bezel	10-184 Ω
10 pcs	A2C60000989	white	12/24 V	single	0 psi	80 psi	-	-	no bezel	no bezel	10-184 Ω
10 pcs	A2C60001023	black	12/24 V	double	0 bar	2 bar	0 psi	28 psi	no bezel	no bezel	10-184 Ω
10 pcs	A2C60001033	white	12/24 V	single	0 bar	2 bar	-	-	no bezel	no bezel	10-184 Ω
10 pcs	A2C60001034	white	12/24 V	double	0 bar	2 bar	0 psi	28 psi	no bezel	no bezel	10-184 Ω

Air pressure



Blister	A2C59514103	black	12/24 V	double	0 psi	150 psi	0 kPa 10 kPa x100 triangle	black	10-184 Ω		
10 pcs	A2C60000998	black	12/24 V	double	0 psi	150 psi	0 kPa 10 kPa x100 no bezel	no bezel	10-184 Ω		

Brake pressure



Blister	A2C59514104	black	12/24 V	single	0 bar	10 bar	-	-	triangle	black	10-184 Ω
Blister	A2C59514105	black	12/24 V	double	0 psi	150 psi	0 kPa 10 kPa x100 triangle	black	10-184 Ω		
Blister	A2C59514195	white	12/24 V	single	0 bar	10 bar	- triangle	chrome	10-184 Ω		
10 pcs	A2C60000969	black	12/24 V	single	0 bar	10 bar	- no bezel	no bezel	10-184 Ω		
10 pcs	A2C60000986	white	12/24 V	single	0 bar	10 bar	- no bezel	no bezel	10-184 Ω		
10 pcs	A2C60000999	black	12/24 V	double	0 psi	150 psi	0 kPa 10 kPa x100 no bezel	no bezel	10-184 Ω		

Packaging	Part number	Dial color	Operating voltage	Dial scale	Outer scale	Outer scale Max	Inner scale	Inner scale	Bezel shape	Bezel color	Input signal
-----------	-------------	------------	-------------------	------------	-------------	-----------------	-------------	-------------	-------------	-------------	--------------

Ø 52 MM

Pressure, no bezel symbol



Blister	A2C59514101	black	12/24 V	single	0 psi	100 psi	triangle	black	10-184 Ω		
Blister	A2C59514194	white	12/24 V	single	0 psi	150 psi	triangle	chrome	10-184 Ω		
10 pcs	A2C60000975	black	12/24 V	single	0 psi	100 psi	no bezel	no bezel	10-184 Ω		
10 pcs	A2C60000992	white	12/24 V	single	0 psi	150 psi	no bezel	no bezel	10-184 Ω		

Fuel level



Blister	A2C59514079	black	12/24 V	single	0	1/1	round	black	90-0,5 Ω		
Blister	A2C59514080	black	12/24 V	single	0	1/1	triangle	chrome	90-0,5 Ω		
Blister	A2C59514081	black	12/24 V	single	0	1/1	triangle	black	90-0,5 Ω		
Blister	A2C59514082	black	12/24 V	single	0	1/1	round	black	3-180 Ω		
Blister	A2C59514083	black	12/24 V	single	0	1/1	triangle	chrome	3-180 Ω		
Blister	A2C59514084	black	12/24 V	single	0	1/1	triangle	black	3-180 Ω		
Blister	A2C59514085	black	12/24 V	single	E	F	round	black	0-90 Ω		
Blister	A2C59514086	black	12/24 V	single	E	F	triangle	chrome	0-90 Ω		
Blister	A2C59514087	black	12/24 V	single	E	F	triangle	black	0-90 Ω		
Blister	A2C59514088	black	12/24 V	single	E	F	round	black	90-0,5 Ω		
Blister	A2C59514089	black	12/24 V	single	E	F	triangle	chrome	90-0,5 Ω		
Blister	A2C59514090	black	12/24 V	single	E	F	triangle	black	90-0,5 Ω		
Blister	A2C59514091	black	12/24 V	single	E	F	round	black	3-180 Ω		
Blister	A2C59514092	black	12/24 V	single	E	F	triangle	chrome	3-180 Ω		
Blister	A2C59514093	black	12/24 V	single	E	F	triangle	black	3-180 Ω		
Blister	A2C59514094	black	12/24 V	single	E	F	round	black	240-33,5 Ω		
Blister	A2C59514095	black	12/24 V	single	E	F	triangle	chrome	240-33,5 Ω		
Blister	A2C59514096	black	12/24 V	single	E	F	triangle	black	240-33,5 Ω		
Blister	A2C59514182	white	12/24 V	single	0	1/1	round	white	90-0,5 Ω		
Blister	A2C59514183	white	12/24 V	single	0	1/1	triangle	chrome	90-0,5 Ω		
Blister	A2C59514184	white	12/24 V	single	0	1/1	round	white	3-180 Ω		
Blister	A2C59514185	white	12/24 V	single	0	1/1	triangle	chrome	3-180 Ω		
Blister	A2C59514186	white	12/24 V	single	E	F	round	white	0-90 Ω		
Blister	A2C59514187	white	12/24 V	single	E	F	triangle	chrome	0-90 Ω		
Blister	A2C59514188	white	12/24 V	single	E	F	round	white	90-0,5 Ω		
Blister	A2C59514189	white	12/24 V	single	E	F	triangle	chrome	90-0,5 Ω		
Blister	A2C59514190	white	12/24 V	single	E	F	round	white	240-33,5 Ω		
Blister	A2C59514191	white	12/24 V	single	E	F	triangle	chrome	240-33,5 Ω		
10 pcs	A2C60001050	black	12/24 V	single	0	1/1	no bezel	no bezel	3-180 Ω		
10 pcs	A2C60001051	black	12/24 V	single	0	1/1	no bezel	no bezel	90-0,5 Ω		
10 pcs	A2C60001052	black	12/24 V	single	E	F	no bezel	no bezel	3-180 Ω		
10 pcs	A2C60001053	black	12/24 V	single	E	F	no bezel	no bezel	240-33,5 Ω		
10 pcs	A2C60001054	black	12/24 V	single	E	F	no bezel	no bezel	0-90 Ω		
10 pcs	A2C60001055	black	12/24 V	single	E	F	no bezel	no bezel	90-0,5 Ω		

Packaging	Part number	Dial color	Operating voltage	Dial scale	Outer scale	Outer scale Max	Inner scale	Inner scale	Bezel shape	Bezel color	Input signal
10 pcs	A2C60001056	white	12/24 V	single	0	1/1	no bezel	no bezel	3-180 Ω		
10 pcs	A2C60001057	white	12/24 V	single	0	1/1	no bezel	no bezel	90-0,5 Ω		
10 pcs	A2C60001058	white	12/24 V	single	E	F	no bezel	no bezel	240-33,5 Ω		
10 pcs	A2C60001059	white	12/24 V	single	E	F	no bezel	no bezel	0-90 Ω		
10 pcs	A2C60001060	white	12/24 V	single	E	F	no bezel	no bezel	90-0,5 Ω		

Fresh water level



Blister	A2C59514097	black	12/24 V	single	0	1/1	round	black	3-180 Ω		
Blister	A2C59514098	black	12/24 V	single	0	1/1	triangle	chrome	3-180 Ω		
Blister	A2C59514099	black	12/24 V	single	E	F	round	black	3-180 Ω		
Blister	A2C59514100	black	12/24 V	single	E	F	triangle	chrome	3-180 Ω		
Blister	A2C59514192	white	12/24 V	single	0	1/1	round	white	3-180 Ω		
Blister	A2C59514193	white	12/24 V	single	E	F	round	white	3-180 Ω		
Blister	A2C59514676	black	12/24 V	single	0	1/1	round	black	20 mA		
Blister	A2C59514677	white	12/24 V	single	0	1/1	round	white	20 mA		
10 pcs	A2C60001061	black	12/24 V	single	0	1/1	no bezel	no bezel	3-180 Ω		
10 pcs	A2C60001062	black	12/24 V	single	E	F	no bezel	no bezel	3-180 Ω		
10 pcs	A2C60001063	white	12/24 V	single	0	1/1	no bezel	no bezel	3-180 Ω		
10 pcs	A2C60001064	white	12/24 V	single	E	F	no bezel	no bezel	3-180 Ω		
10 pcs	A2C60520086	black	12/24 V	single	0	1/1	no bezel	no bezel	20 mA		
10 pcs	A2C60520087	white	12/24 V	single	0	1/1	no bezel	no bezel	20 mA		

Black water level



Blister	A2C59512342	black	12/24 V	single	0	1/1	round	black	20 mA		
Blister	A2C59512343	white	12/24 V	single	0	1/1	round	white	20 mA		
10 pcs	A2C59510036	black	12/24 V	single	0	1/1	no bezel	no bezel	20 mA		
10 pcs	A2C59510037	white	12/24 V	single	0	1/1	no bezel	no bezel	20 mA		

Coolant liquid temperature



Blister	A2C59514173	black	12/24 V	single	40°C	120°C	triangle	black	287,4-22,7 Ω		
10 pcs	A2C60000952	black	12/24 V	single	40°C	120°C	no bezel	no bezel	287,4-22,7 Ω		

Packaging	Part number	Dial color	Operating voltage	Dial scale	Outer scale	Outer scale Max	Inner scale	Inner scale	Bezel shape	Bezel color	Input signal
-----------	-------------	------------	-------------------	------------	-------------	-----------------	-------------	-------------	-------------	-------------	--------------

Ø 52 MM

Coolant liquid temperature "on-road"



Blister	A2C59514159	black	12/24 V	single	40°C	120°C	-	-	triangle	black	287,4-22,7 Ω
Blister	A2C59514170	black	12/24 V	double	40°C	120°C	105°F	250°F	round	black	287,4-22,7 Ω
Blister	A2C59514171	black	12/24 V	double	40°C	120°C	105°F	250°F	triangle	chrome	287,4-22,7 Ω
Blister	A2C59514172	black	12/24 V	double	40°C	120°C	105°F	250°F	triangle	black	287,4-22,7 Ω
Blister	A2C59514175	black	12/24 V	single	100°F	240°F	-	-	triangle	black	384-29 Ω
Blister	A2C59514176	black	12/24 V	double	100°F	250°F	40°C	120°C	round	black	287,4-22,7 Ω
Blister	A2C59514177	black	12/24 V	double	100°F	250°F	40°C	120°C	triangle	chrome	287,4-22,7 Ω
Blister	A2C59514178	black	12/24 V	double	100°F	250°F	40°C	120°C	triangle	black	287,4-22,7 Ω
Blister	A2C59514179	black	12/24 V	single	100°F	250°F	-	-	triangle	black	287,4-22,7 Ω
Blister	A2C59514237	white	12/24 V	double	40°C	120°C	105°F	250°F	round	white	287,4-22,7 Ω
Blister	A2C59514238	white	12/24 V	double	40°C	120°C	105°F	250°F	triangle	chrome	287,4-22,7 Ω
Blister	A2C59514239	white	12/24 V	single	40°C	120°C	-	-	triangle	chrome	287,4-22,7 Ω
Blister	A2C59514241	white	12/24 V	double	100°F	250°F	40°C	120°C	round	white	287,4-22,7 Ω
Blister	A2C59514242	white	12/24 V	double	100°F	250°F	40°C	120°C	triangle	chrome	287,4-22,7 Ω
Blister	A2C59514243	white	12/24 V	single	100°F	250°F	-	-	triangle	chrome	287,4-22,7 Ω
10 pcs	A2C60000950	black	12/24 V	single	40°C	120°C	-	-	no bezel	no bezel	287,4-22,7 Ω
10 pcs	A2C60000957	black	12/24 V	single	100°F	240°F	-	-	no bezel	no bezel	384-29 Ω
10 pcs	A2C60000958	black	12/24 V	single	100°F	250°F	-	-	no bezel	no bezel	287,4-22,7 Ω
10 pcs	A2C60000961	white	12/24 V	single	40°C	120°C	-	-	no bezel	no bezel	287,4-22,7 Ω
10 pcs	A2C60000964	white	12/24 V	single	100°F	250°F	-	-	no bezel	no bezel	287,4-22,7 Ω
10 pcs	A2C60001021	white	12/24 V	double	100°F	250°F	40°C	120°C	no bezel	no bezel	287,4-22,7 Ω
10 pcs	A2C60001076	black	12/24 V	double	40°C	120°C	105°F	250°F	no bezel	no bezel	287,4-22,7 Ω
10 pcs	A2C60001078	black	12/24 V	double	100°F	250°F	40°C	120°C	no bezel	no bezel	287,4-22,7 Ω
10 pcs	A2C60001080	white	12/24 V	double	40°C	120°C	105°F	250°F	no bezel	no bezel	287,4-22,7 Ω

Oil temperature "off-road"



Blister	A2C59514163	black	12/24 V	single	50°C	150°C	triangle	black	322,8-18,6 Ω		
Blister	A2C59514236	white	12/24 V	single	120°F	300°F	triangle	chrome	322,8-18,6 Ω		
10 pcs	A2C60000954	black	12/24 V	single	50°C	150°C	no bezel	no bezel	322,8-18,6 Ω		
10 pcs	A2C60000965	white	12/24 V	single	120°F	300°F	no bezel	no bezel	322,8-18,6 Ω		

Packaging	Part number	Dial color	Operating voltage	Dial scale	Outer scale	Outer scale Max	Inner scale	Inner scale	Bezel shape	Bezel color	Input signal
-----------	-------------	------------	-------------------	------------	-------------	-----------------	-------------	-------------	-------------	-------------	--------------

Oil temperature "on-road"



Blister	A2C59514160	black	12/24 V	double	50°C	150°C	120°F	300°F	round	black	322,8-18,6 Ω
Blister	A2C59514161	black	12/24 V	double	50°C	150°C	120°F	300°F	triangle	chrome	322,8-18,6 Ω
Blister	A2C59514162	black	12/24 V	double	50°C	150°C	120°F	300°F	triangle	black	322,8-18,6 Ω
Blister	A2C59514164	black	12/24 V	single	50°C	150°C	-	-	triangle	black	322,8-18,6 Ω
Blister	A2C59514165	black	12/24 V	double	120°F	300°F	50°C	150°C	round	black	322,8-18,6 Ω
Blister	A2C59514166	black	12/24 V	double	120°F	300°F	50°C	150°C	triangle	chrome	322,8-18,6 Ω
Blister	A2C59514167	black	12/24 V	double	120°F	300°F	50°C	150°C	triangle	black	322,8-18,6 Ω
Blister	A2C59514168	black	12/24 V	single	120°F	300°F	-	-	triangle	black	322,8-18,6 Ω
Blister	A2C59514231	white	12/24 V	double	50°C	150°C	120°F	300°F	round	white	322,8-18,6 Ω
Blister	A2C59514232	white	12/24 V	double	50°C	150°C	120°F	300°F	triangle	chrome	322,8-18,6 Ω
Blister	A2C59514233	white	12/24 V	single	50°C	150°C	-	-	triangle	chrome	322,8-18,6 Ω
Blister	A2C59514234	white	12/24 V	double	120°F	300°F	50°C	150°C	round	white	322,8-18,6 Ω
Blister	A2C59514235	white	12/24 V	double	120°F	300°F	50°C	150°C	triangle	chrome	322,8-18,6 Ω
10 pcs	A2C60000953	black	12/24 V	single	50°C	150°C	-	-	no bezel	no bezel	322,8-18,6 Ω
10 pcs	A2C60000959	black	12/24 V	single	120°F	300°F	-	-	no bezel	no bezel	322,8-18,6 Ω
10 pcs	A2C60000962	white	12/24 V	single	50°C	150°C	-	-	no bezel	no bezel	322,8-18,6 Ω
10 pcs	A2C60001020	white	12/24 V	double	50°C	150°C	120°F	300°F	no bezel	no bezel	322,8-18,6 Ω
10 pcs	A2C60001022	white	12/24 V	double	120°F	300°F	50°C	150°C	no bezel	no bezel	322,8-18,6 Ω
10 pcs	A2C60001077	black	12/24 V	double	50°C	150°C	120°F	300°F	no bezel	no bezel	322,8-18,6 Ω
10 pcs	A2C60001079	black	12/24 V	double	120°F	300°F	50°C	150°C	no bezel	no bezel	322,8-18,6 Ω

Gearbox oil temperature



Blister	A2C59514169	black	12/24 V	single	50°C	150°C	triangle	black	322,8-18,6 Ω		
10 pcs	A2C60000955	black	12/24 V	single	50°C	150°C	no bezel	no bezel	322,8-18,6 Ω		

Hydraulic oil temperature



Blister	A2C59514158	black	12/24 V	single	20°C	100°C	triangle	black	287,4-22,7 Ω		
Blister	A2C59514174	black	12/24 V	single	40°C	120°C	triangle	black	287,4-22,7 Ω		
10 pcs	A2C60000949	black	12/24 V	single	20°C	100°C	no bezel	no bezel	287,4-22,7 Ω		
10 pcs	A2C60000951	black	12/24 V	single	40°C	120°C	no bezel	no bezel	287,4-22,7 Ω		

Packaging	Part number	Dial color	Operating voltage	Dial scale	Outer scale	Outer scale Max	Inner scale	Inner scale	Bezel shape	Bezel color	Input signal
-----------	-------------	------------	-------------------	------------	-------------	-----------------	-------------	-------------	-------------	-------------	--------------

Ø 52 MM

Cylinder temperature



Blister	A2C59514156	black	12/24 V	single	60°C	200°C	triangle	black	482,5-14,3 Ω		
Blister	A2C59514157	black	12/24 V	single	150°F	400°F	triangle	black	482,5-14,3 Ω		
10 pcs	A2C60000956	black	12/24 V	single	60°C	200°C	no bezel	no bezel	482,5-14,3 Ω		
10 pcs	A2C60000960	black	12/24 V	single	150°F	400°F	no bezel	no bezel	482,5-14,3 Ω		

External temperature



Blister	A2C59512318	black	12/24 V	single	-25°C	+50°C	triangle	black	2 kΩ		
Blister	A2C59512319	black	12/24 V	single	-10°F	+120°F	triangle	black	2 kΩ		
Blister	A2C59512320	white	12/24 V	single	-25°C	+50°C	triangle	chrome	2 kΩ		
Blister	A2C59512321	white	12/24 V	single	-10°F	+120°F	triangle	chrome	2 kΩ		
Blister	A2C59512336	black	12/24 V	single	-25°C	+50°C	round	black	2 kΩ		
Blister	A2C59512337	black	12/24 V	single	-10°F	+120°F	round	black	2 kΩ		
Blister	A2C59512338	white	12/24 V	single	-25°C	+50°C	round	white	2 kΩ		
Blister	A2C59512339	white	12/24 V	single	-10°F	+120°F	round	white	2 kΩ		
10 pcs	A2C59510030	black	12/24 V	single	-25°C	+50°C	no bezel	no bezel	2 kΩ		
10 pcs	A2C59510031	black	12/24 V	single	-10°F	+120°F	no bezel	no bezel	2 kΩ		
10 pcs	A2C59510032	white	12/24 V	single	-25°C	+50°C	no bezel	no bezel	2 kΩ		
10 pcs	A2C59510033	white	12/24 V	single	-10°F	+120°F	no bezel	no bezel	2 kΩ		

Pyrometer



Blister	A2C59512314	black	12/24 V	single	100°C	900°C	triangle	black	37 mV		
Blister	A2C59512315	white	12/24 V	single	100°C	900°C	triangle	chrome	37 mV		
Blister	A2C59512316	black	12/24 V	single	250°F	1650°F	triangle	black	37 mV		
Blister	A2C59512317	white	12/24 V	single	250°F	1650°F	triangle	chrome	37 mV		
Blister	A2C59512332	black	12/24 V	single	100°C	900°C	round	black	37 mV		
Blister	A2C59512333	white	12/24 V	single	100°C	900°C	round	white	37 mV		
Blister	A2C59512334	black	12/24 V	single	250°F	1650°F	round	black	37 mV		
Blister	A2C59512335	white	12/24 V	single	250°F	1650°F	round	white	37 mV		
10 pcs	A2C59510026	black	12/24 V	single	100°C	900°C	no bezel	no bezel	37 mV		
10 pcs	A2C59510027	white	12/24 V	single	100°C	900°C	no bezel	no bezel	37 mV		
10 pcs	A2C59510028	black	12/24 V	single	250°F	1650°F	no bezel	no bezel	37 mV		
10 pcs	A2C59510029	white	12/24 V	single	250°F	1650°F	no bezel	no bezel	37 mV		

Packaging	Part number	Dial color	Operating voltage	Dial scale	Outer scale	Outer scale Max	Inner scale	Inner scale	Bezel shape	Bezel color	Input signal
-----------	-------------	------------	-------------------	------------	-------------	-----------------	-------------	-------------	-------------	-------------	--------------

Voltmeter



Blister	A2C59512457	black	24 V	single	18 V	32 V	triangle	chrome			
Blister	A2C59512458	black	24 V	single	18 V	32 V	round	black			
Blister	A2C59512459	white	24 V	single	18 V	32 V	round	white			
Blister	A2C59514840	black	24 V	single	18 V	32 V	triangle	black			
Blister	A2C59514841	white	24 V	single	18 V	32 V	triangle	chrome			
10 pcs	A2C60100078	black	24 V	single	18 V	32 V	no bezel	no bezel			
10 pcs	A2C60100079	white	24 V	single	18 V	32 V	no bezel	no bezel			
Blister	A2C59512545	black	12 V	single	8 V	16 V	round	black			
Blister	A2C59512546	white	12 V	single	8 V	16 V	round	white			
Blister	A2C59514850	white	12 V	single	8 V	16 V	triangle	chrome			
Blister	A2C59514851	black	12 V	single	8 V	16 V	triangle	black			
10 pcs	A2C60100178	black	12 V	single	8 V	16 V	no bezel	no bezel			
10 pcs	A2C60100179	white	12 V	single	8 V	16 V	no bezel	no bezel			

Clock



Blister	A2C59513443	white	12 V	single	round	white					
Blister	A2C59513444	white	24 V	single	round	white					
Blister	A2C59513445	black	12 V	single	round	black					
Blister	A2C59513446	black	24 V	single	round	black					
10 pcs	A2C60001015	white	12 V	single	no bezel	no bezel					
10 pcs	A2C60001016	white	24 V	single	no bezel	no bezel					
10 pcs	A2C60001017	black	12 V	single	no bezel	no bezel					
10 pcs	A2C60001018	black	24 V	single	no bezel	no bezel					

Rudder angle



Blister	A2C59514154	black	12/24 V	single	40° Port	40° Stb	round	black	3-180 Ω		
Blister	A2C59514155	black	12/24 V	single	40° Port	40° Stb	triangle	chrome	3-180 Ω		
Blister	A2C59514230	white	12/24 V	single	40° Port	40° Stb	round	white	3-180 Ω		
10 pcs	A2C60001065	black	12/24 V	single	40° Port	40° Stb	no bezel	no bezel	3-180 Ω		
10 pcs	A2C60001066	white	12/24 V	single	40° Port	40° Stb	no bezel	no bezel	3-180 Ω		

Packaging	Part number	Dial color	Operating voltage	Dial scale	Outer scale	Outer scale Max	Inner scale	Inner scale	Bezel shape	Bezel color	Input signal
-----------	-------------	------------	-------------------	------------	-------------	-----------------	-------------	-------------	-------------	-------------	--------------

Ø 52 MM

Trim



Blister	A2C59514180	black	12/24 V	single	Up	Down	round	black	84-5 Ω		
Blister	A2C59514181	black	12/24 V	single	Up	Down	triangle	chrome	84-5 Ω		
Blister	A2C59514244	white	12/24 V	single	Up	Down	round	white	84-5 Ω		
10 pcs	A2C60001067	black	12/24 V	single	Up	Down	no bezel	no bezel	84-5 Ω		
10 pcs	A2C60001068	white	12/24 V	single	Up	Down	no bezel	no bezel	84-5 Ω		



Packaging	Part number	Dial color	Operating voltage	Dial scale	Outer scale	Outer scale Max	Bezel shape	Bezel color	Input signal
-----------	-------------	------------	-------------------	------------	-------------	-----------------	-------------	-------------	--------------

Ø 85 MM

Tachometer without LCD



Blister	A2C59512430	black	12/24 V	single	0 rpm	3000 rpm	round	black	terminal W, Inductive, Generator, Hall effect, terminal 1
Blister	A2C59512431	black	12/24 V	single	0 rpm	4000 rpm	round	black	terminal W, Inductive, Generator, Hall effect, terminal 1
Blister	A2C59512432	black	12/24 V	single	0 rpm	6000 rpm	round	black	terminal W, Inductive, Generator, Hall effect, terminal 1
Blister	A2C59512433	white	12/24 V	single	0 rpm	3000 rpm	round	white	terminal W, Inductive, Generator, Hall effect, terminal 1
Blister	A2C59512434	white	12/24 V	single	0 rpm	4000 rpm	round	white	terminal W, Inductive, Generator, Hall effect, terminal 1
Blister	A2C59512435	white	12/24 V	single	0 rpm	6000 rpm	round	white	terminal W, Inductive, Generator, Hall effect, terminal 1
Blister	A2C59512436	black	12/24 V	single	0 rpm	3000 rpm	triangle	black	terminal W, Inductive, Generator, Hall effect, terminal 1
Blister	A2C59512437	black	12/24 V	single	0 rpm	4000 rpm	triangle	black	terminal W, Inductive, Generator, Hall effect, terminal 1
Blister	A2C59512438	black	12/24 V	single	0 rpm	7000 rpm	triangle	black	terminal W, Inductive, Generator, Hall effect, terminal 1
Blister	A2C59512439	black	12/24 V	single	0 rpm	10000 rpm	triangle	black	terminal W, Inductive, Generator, Hall effect, terminal 1
Blister	A2C59512440	white	12/24 V	single	0 rpm	3000 rpm	triangle	chrome	terminal W, Inductive, Generator, Hall effect, terminal 1
Blister	A2C59512441	white	12/24 V	single	0 rpm	4000 rpm	triangle	chrome	terminal W, Inductive, Generator, Hall effect, terminal 1
Blister	A2C59512442	white	12/24 V	single	0 rpm	7000 rpm	triangle	chrome	terminal W, Inductive, Generator, Hall effect, terminal 1
Blister	A2C59512443	white	12/24 V	single	0 rpm	10000 rpm	triangle	chrome	terminal W, Inductive, Generator, Hall effect, terminal 1
10 pcs	A2C59510203	black	12/24 V	single	0 rpm	3000 rpm	no bezel	no bezel	terminal W, Inductive, Generator, Hall effect, terminal 1
10 pcs	A2C59510204	black	12/24 V	single	0 rpm	4000 rpm	no bezel	no bezel	terminal W, Inductive, Generator, Hall effect, terminal 1
10 pcs	A2C59510205	black	12/24 V	single	0 rpm	6000 rpm	no bezel	no bezel	terminal W, Inductive, Generator, Hall effect, terminal 1
10 pcs	A2C59510206	white	12/24 V	single	0 rpm	3000 rpm	no bezel	no bezel	terminal W, Inductive, Generator, Hall effect, terminal 1
10 pcs	A2C59510207	white	12/24 V	single	0 rpm	4000 rpm	no bezel	no bezel	terminal W, Inductive, Generator, Hall effect, terminal 1
10 pcs	A2C59510208	white	12/24 V	single	0 rpm	6000 rpm	no bezel	no bezel	terminal W, Inductive, Generator, Hall effect, terminal 1
10 pcs	A2C59510211	black	12/24 V	single	0 rpm	7000 rpm	no bezel	no bezel	terminal W, Inductive, Generator, Hall effect, terminal 1
10 pcs	A2C59510212	black	12/24 V	single	0 rpm	10000 rpm	no bezel	no bezel	terminal W, Inductive, Generator, Hall effect, terminal 1
10 pcs	A2C59510215	white	12/24 V	single	0 rpm	7000 rpm	no bezel	no bezel	terminal W, Inductive, Generator, Hall effect, terminal 1
10 pcs	A2C59510216	white	12/24 V	single	0 rpm	10000 rpm	no bezel	no bezel	terminal W, Inductive, Generator, Hall effect, terminal 1



Packaging	Part number	Dial color	Operating voltage	Dial scale	Outer scale	Outer scale Max	Inner scale min	Inner scale max	Bezel shape	Bezel color	Input signal
-----------	-------------	------------	-------------------	------------	-------------	-----------------	-----------------	-----------------	-------------	-------------	--------------

Ø 85 MM

Speedometer with LCD



Blister	A2C59512366	black	12/24 V	single	0 km/h	25 km/h	-	-	triangle	black	Blocking oscillator
Blister	A2C59512367	black	12/24 V	single	0 km/h	60 km/h	-	-	triangle	black	Blocking oscillator
Blister	A2C59512368	black	12/24 V	single	0 km/h	80 km/h	-	-	triangle	black	Blocking oscillator
Blister	A2C59512369	black	12/24 V	single	0 km/h	120 km/h	-	-	triangle	black	Blocking oscillator
Blister	A2C59512370	black	12/24 V	single	0 km/h	200 km/h	-	-	triangle	black	Blocking oscillator
Blister	A2C59512371	black	12/24 V	single	0 km/h	300 km/h	-	-	triangle	black	Blocking oscillator
Blister	A2C59512372	black	12/24 V	double	0 mph	30 mph	0 km/h	50 km/h	triangle	black	Blocking oscillator
Blister	A2C59512373	black	12/24 V	double	0 mph	60 mph	0 km/h	95 km/h	triangle	black	Blocking oscillator
Blister	A2C59512374	black	12/24 V	double	0 mph	85 mph	0 km/h	140 km/h	triangle	black	Blocking oscillator
Blister	A2C59512375	black	12/24 V	double	0 mph	120 mph	0 km/h	200 km/h	triangle	black	Blocking oscillator
Blister	A2C59512376	black	12/24 V	double	0 mph	140 mph	0 km/h	220 km/h	triangle	black	Blocking oscillator
Blister	A2C59512377	black	12/24 V	single	0 mph	120 mph	-	-	triangle	black	Blocking oscillator
Blister	A2C59512378	black	12/24 V	single	0 mph	160 mph	-	-	triangle	black	Blocking oscillator
Blister	A2C59512379	white	12/24 V	single	0 km/h	60 km/h	-	-	triangle	chrome	Blocking oscillator
Blister	A2C59512380	white	12/24 V	single	0 km/h	80 km/h	-	-	triangle	chrome	Blocking oscillator
Blister	A2C59512381	white	12/24 V	single	0 km/h	120 km/h	-	-	triangle	chrome	Blocking oscillator
Blister	A2C59512382	white	12/24 V	single	0 km/h	200 km/h	-	-	triangle	chrome	Blocking oscillator
Blister	A2C59512383	white	12/24 V	single	0 mph	120 mph	-	-	triangle	chrome	Blocking oscillator
Blister	A2C59512384	white	12/24 V	single	0 mph	160 mph	-	-	triangle	chrome	Blocking oscillator
Blister	A2C59512385	white	12/24 V	double	0 mph	30 mph	0 km/h	50 km/h	triangle	chrome	Blocking oscillator
Blister	A2C59512386	white	12/24 V	double	0 mph	60 mph	0 km/h	95 km/h	triangle	chrome	Blocking oscillator
Blister	A2C59512387	white	12/24 V	double	0 mph	85 mph	0 km/h	140 km/h	triangle	chrome	Blocking oscillator
Blister	A2C59512388	white	12/24 V	double	0 mph	120 mph	0 km/h	200 km/h	triangle	chrome	Blocking oscillator
Blister	A2C59512389	white	12/24 V	double	0 mph	140 mph	0 km/h	220 km/h	triangle	chrome	Blocking oscillator
10 pcs	A2C59510062	black	12/24 V	single	0 km/h	25 km/h	-	-	no bezel	no bezel	Blocking oscillator
10 pcs	A2C59510063	black	12/24 V	single	0 km/h	60 km/h	-	-	no bezel	no bezel	Blocking oscillator
10 pcs	A2C59510064	black	12/24 V	single	0 km/h	80 km/h	-	-	no bezel	no bezel	Blocking oscillator
10 pcs	A2C59510065	black	12/24 V	single	0 km/h	120 km/h	-	-	no bezel	no bezel	Blocking oscillator
10 pcs	A2C59510066	black	12/24 V	single	0 km/h	200 km/h	-	-	no bezel	no bezel	Blocking oscillator
10 pcs	A2C59510067	black	12/24 V	single	0 km/h	300 km/h	-	-	no bezel	no bezel	Blocking oscillator
10 pcs	A2C59510068	black	12/24 V	double	0 mph	30 mph	0 km/h	50 km/h	no bezel	no bezel	Blocking oscillator
10 pcs	A2C59510069	black	12/24 V	double	0 mph	60 mph	0 km/h	95 km/h	no bezel	no bezel	Blocking oscillator
10 pcs	A2C59510070	black	12/24 V	double	0 mph	85 mph	0 km/h	140 km/h	no bezel	no bezel	Blocking oscillator
10 pcs	A2C59510071	black	12/24 V	double	0 mph	120 mph	0 km/h	200 km/h	no bezel	no bezel	Blocking oscillator
10 pcs	A2C59510072	black	12/24 V	double	0 mph	140 mph	0 km/h	220 km/h	no bezel	no bezel	Blocking oscillator
10 pcs	A2C59510073	black	12/24 V	single	0 mph	120 mph	-	-	no bezel	no bezel	Blocking oscillator
10 pcs	A2C59510074	black	12/24 V	single	0 mph	160 mph	-	-	no bezel	no bezel	Blocking oscillator
10 pcs	A2C59510075	white	12/24 V	single	0 km/h	60 km/h	-	-	no bezel	no bezel	Blocking oscillator
10 pcs	A2C59510076	white	12/24 V	single	0 km/h	80 km/h	-	-	no bezel	no bezel	Blocking oscillator
10 pcs	A2C59510077	white	12/24 V	single	0 km/h	120 km/h	-	-	no bezel	no bezel	Blocking oscillator
10 pcs	A2C59510078	white	12/24 V	single	0 km/h	200 km/h	-	-	no bezel	no bezel	Blocking oscillator
10 pcs	A2C59510079	white	12/24 V	single	0 mph	120 mph	-	-	no bezel	no bezel	Blocking oscillator
10 pcs	A2C59510080	white	12/24 V	single	0 mph	160 mph	-	-	no bezel	no bezel	Blocking oscillator
10 pcs	A2C59510081	white	12/24 V	double	0 mph	30 mph	0 km/h	50 km/h	no bezel	no bezel	Blocking oscillator
10 pcs	A2C59510082	white	12/24 V	double	0 mph	60 mph	0 km/h	95 km/h	no bezel	no bezel	Blocking oscillator
10 pcs	A2C59510083	white	12/24 V	double	0 mph	85 mph	0 km/h	140 km/h	no bezel	no bezel	Blocking oscillator
10 pcs	A2C59510084	white	12/24 V	double	0 mph	120 mph	0 km/h	200 km/h	no bezel	no bezel	Blocking oscillator
10 pcs	A2C59510085	white	12/24 V	double	0 mph	140 mph	0 km/h	220 km/h	no bezel	no bezel	Blocking oscillator

Packaging	Part number	Dial color	Operating voltage	Dial scale	Outer scale	Outer scale Max	Bezel shape	Bezel color	Input signal
-----------	-------------	------------	-------------------	------------	-------------	-----------------	-------------	-------------	--------------

Ø 85 MM

Wind direction



Blister	A2C59514246	black	12/24 V	single	60° Port	60° Stb	round	black	NMEA
Blister	A2C59514249	white	12/24 V	single	60° Port	60° Stb	round	white	NMEA
10 pcs	A2C59501320	black	12/24 V	single	60° Port	60° Stb	no bezel	no bezel	NMEA
10 pcs	A2C59501323	white	12/24 V	single	60° Port	60° Stb	no bezel	no bezel	NMEA

Depth



Blister	A2C59514247	black	12/24 V	single	0 m	30 m	round	black	NMEA
Blister	A2C59514250	white	12/24 V	single	0 m	30 m	round	white	NMEA
10 pcs	A2C59501321	black	12/24 V	single	0 m	30 m	no bezel	no bezel	NMEA
10 pcs	A2C59501324	white	12/24 V	single	0 m	30 m	no bezel	no bezel	NMEA

Sumlog®



Blister	A2C59512404	black	12/24 V	single	0 kn	12 kn	round	black	Hall, NMEA
Blister	A2C59512405	black	12/24 V	single	0 kn	50 kn	round	black	Hall, NMEA
Blister	A2C59512406	black	12/24 V	single	0 mph	60 mph	round	black	Hall, NMEA
Blister	A2C59512407	white	12/24 V	single	0 kn	12 kn	round	white	Hall, NMEA
Blister	A2C59512408	white	12/24 V	single	0 kn	50 kn	round	white	Hall, NMEA
Blister	A2C59512409	white	12/24 V	single	0 mph	60 mph	round	white	Hall, NMEA
10 pcs	A2C59510100	black	12/24 V	single	0 kn	12 kn	no bezel	no bezel	Hall, NMEA
10 pcs	A2C59510101	black	12/24 V	single	0 kn	50 kn	no bezel	no bezel	Hall, NMEA
10 pcs	A2C59510102	black	12/24 V	single	0 mph	60 mph	no bezel	no bezel	Hall, NMEA
10 pcs	A2C59510103	white	12/24 V	single	0 kn	12 kn	no bezel	no bezel	Hall, NMEA
10 pcs	A2C59510104	white	12/24 V	single	0 kn	50 kn	no bezel	no bezel	Hall, NMEA
10 pcs	A2C59510105	white	12/24 V	single	0 mph	60 mph	no bezel	no bezel	Hall, NMEA

Packaging	Part number	Dial color	Operating voltage	Dial scale	Outer scale	Outer scale Max	Bezel shape	Bezel color	Input signal
-----------	-------------	------------	-------------------	------------	-------------	-----------------	-------------	-------------	--------------

Ø 85 MM

Synchronizer



Blister	A2C59512402	black	12/24 V	single	-500 rpm	+500 rpm	round	black	terminal W, Inductive, terminal 1
Blister	A2C59512403	white	12/24 V	single	-500 rpm	+500 rpm	round	white	W, 1, Ind
10 pcs	A2C59510098	black	12/24 V	single	-500 rpm	+500 rpm	no bezel	no bezel	W, 1, Ind
10 pcs	A2C59510099	white	12/24 V	single	-500 rpm	+500 rpm	no bezel	no bezel	W, 1, Ind

Wind instrument



Blister	A2C59514245	black	12/24 V	single	30° Port	30° Stb	round	black	NMEA
Blister	A2C59514248	white	12/24 V	single	30° Port	30° Stb	round	white	NMEA
10 pcs	A2C59501319	black	12/24 V	single	30° Port	30° Stb	no bezel	no bezel	NMEA
10 pcs	A2C59501322	white	12/24 V	single	30° Port	30° Stb	no bezel	no bezel	NMEA

Rudder angle



Blister	A2C59512410	black	12/24 V	single	-45°	+45°	round	black	3-180 Ω
Blister	A2C59512411	white	12/24 V	single	-45°	+45°	round	white	3-180 Ω
10 pcs	A2C59510106	black	12/24 V	single	-45°	+45°	no bezel	no bezel	3-180 Ω
10 pcs	A2C59510107	white	12/24 V	single	-45°	+45°	no bezel	no bezel	3-180 Ω

Packaging	Part number	Dial color	Operating voltage	Dial scale	Outer scale	Outer scale Max	Bezel shape	Bezel color	Input signal
-----------	-------------	------------	-------------------	------------	-------------	-----------------	-------------	-------------	--------------

Ø 110 MM

Tachometer with LCD



Blister	A2C59512412	black	12/24 V	single	0 rpm	1800 rpm	triangle	black	terminal W, Inductive, Generator, Hall effect, terminal 1
Blister	A2C59512413	black	12/24 V	single	0 rpm	3000 rpm	triangle	black	terminal W, Inductive, Generator, Hall effect, terminal 1
Blister	A2C59512414	black	12/24 V	single	0 rpm	4000 rpm	triangle	black	terminal W, Inductive, Generator, Hall effect, terminal 1
Blister	A2C59512415	black	12/24 V	single	0 rpm	5000 rpm	triangle	black	terminal W, Inductive, Generator, Hall effect, terminal 1
Blister	A2C59512416	black	12/24 V	single	0 rpm	6000 rpm	triangle	black	terminal W, Inductive, Generator, Hall effect, terminal 1
Blister	A2C59512417	black	12/24 V	single	0 rpm	7000 rpm	triangle	black	terminal W, Inductive, Generator, Hall effect, terminal 1
Blister	A2C59512418	black	12/24 V	single	0 rpm	8000 rpm	triangle	black	terminal W, Inductive, Generator, Hall effect, terminal 1
10 pcs	A2C59510108	black	12/24 V	single	0 rpm	1800 rpm	no bezel	no bezel	terminal W, Inductive, Generator, Hall effect, terminal 1
10 pcs	A2C59510109	black	12/24 V	single	0 rpm	3000 rpm	no bezel	no bezel	terminal W, Inductive, Generator, Hall effect, terminal 1
10 pcs	A2C59510110	black	12/24 V	single	0 rpm	4000 rpm	no bezel	no bezel	terminal W, Inductive, Generator, Hall effect, terminal 1
10 pcs	A2C59510111	black	12/24 V	single	0 rpm	5000 rpm	no bezel	no bezel	terminal W, Inductive, Generator, Hall effect, terminal 1
10 pcs	A2C59510112	black	12/24 V	single	0 rpm	6000 rpm	no bezel	no bezel	terminal W, Inductive, Generator, Hall effect, terminal 1
10 pcs	A2C59510113	black	12/24 V	single	0 rpm	7000 rpm	no bezel	no bezel	terminal W, Inductive, Generator, Hall effect, terminal 1
10 pcs	A2C59510114	black	12/24 V	single	0 rpm	8000 rpm	no bezel	no bezel	terminal W, Inductive, Generator, Hall effect, terminal 1

Tachometer without LCD



Blister	A2C59512444	black	12/24 V	single	0 rpm	3000 rpm	triangle	black	terminal W, Inductive, Generator, Hall effect, terminal 1
Blister	A2C59512445	black	12/24 V	single	0 rpm	4000 rpm	triangle	black	terminal W, Inductive, Generator, Hall effect, terminal 1
Blister	A2C59512446	black	12/24 V	single	0 rpm	7000 rpm	triangle	black	terminal W, Inductive, Generator, Hall effect, terminal 1
Blister	A2C59512447	black	12/24 V	single	0 rpm	10000 rpm	triangle	black	terminal W, Inductive, Generator, Hall effect, terminal 1
10 pcs	A2C59510217	black	12/24 V	single	0 rpm	3000 rpm	no bezel	no bezel	terminal W, Inductive, Generator, Hall effect, terminal 1
10 pcs	A2C59510218	black	12/24 V	single	0 rpm	4000 rpm	no bezel	no bezel	terminal W, Inductive, Generator, Hall effect, terminal 1
10 pcs	A2C59510219	black	12/24 V	single	0 rpm	7000 rpm	no bezel	no bezel	terminal W, Inductive, Generator, Hall effect, terminal 1
10 pcs	A2C59510220	black	12/24 V	single	0 rpm	10000 rpm	no bezel	no bezel	terminal W, Inductive, Generator, Hall effect, terminal 1

Packaging	Part number	Dial color	Operating voltage	Dial scale	Outer scale	Outer scale Max	Inner scale min	Inner scale max	Bezel shape	Bezel color	Input signal
-----------	-------------	------------	-------------------	------------	-------------	-----------------	-----------------	-----------------	-------------	-------------	--------------

Ø 110 MM

Speedometer with LCD



Blister	A2C59512419	black	12/24 V	single	0 km/h	25 km/h	-	-	triangle	black	Inductive, Hall, Oscillateur bloqué
Blister	A2C59512420	black	12/24 V	single	0 km/h	60 km/h	-	-	triangle	black	Inductive, Hall, Oscillateur bloqué
Blister	A2C59512421	black	12/24 V	single	0 km/h	80 km/h	-	-	triangle	black	Inductive, Hall, Oscillateur bloqué
Blister	A2C59512422	black	12/24 V	single	0 km/h	120 km/h	-	-	triangle	black	Inductive, Hall, Oscillateur bloqué
Blister	A2C59512423	black	12/24 V	single	0 km/h	200 km/h	-	-	triangle	black	Inductive, Hall, Oscillateur bloqué
Blister	A2C59512424	black	12/24 V	single	0 km/h	300 km/h	-	-	triangle	black	Inductive, Hall, Oscillateur bloqué
Blister	A2C59512425	black	12/24 V	single	0 mph	120 mph	-	-	triangle	black	Inductive, Hall, Oscillateur bloqué
Blister	A2C59512426	black	12/24 V	double	0 mph	60 mph	0 km/h	95 km/h	triangle	black	Inductive, Hall, Oscillateur bloqué
Blister	A2C59512427	black	12/24 V	double	0 mph	85 mph	0 km/h	140 km/h	triangle	black	Inductive, Hall, Oscillateur bloqué
Blister	A2C59512428	black	12/24 V	double	0 mph	140 mph	0 km/h	220 km/h	triangle	black	Inductive, Hall, Oscillateur bloqué
Blister	A2C59512429	black	12/24 V	double	0 mph	220 mph	0 km/h	360 km/h	triangle	black	Inductive, Hall, Oscillateur bloqué
10 pcs	A2C59510115	black	12/24 V	single	0 km/h	25 km/h	-	-	no bezel	no bezel	Inductive, Hall, Oscillateur bloqué
10 pcs	A2C59510116	black	12/24 V	single	0 km/h	60 km/h	-	-	no bezel	no bezel	Inductive, Hall, Oscillateur bloqué
10 pcs	A2C59510117	black	12/24 V	single	0 km/h	80 km/h	-	-	no bezel	no bezel	Inductive, Hall, Oscillateur bloqué
10 pcs	A2C59510118	black	12/24 V	single	0 km/h	120 km/h	-	-	no bezel	no bezel	Inductive, Hall, Oscillateur bloqué
10 pcs	A2C59510119	black	12/24 V	single	0 km/h	200 km/h	-	-	no bezel	no bezel	Inductive, Hall, Oscillateur bloqué
10 pcs	A2C59510120	black	12/24 V	single	0 km/h	300 km/h	-	-	no bezel	no bezel	Inductive, Hall, Oscillateur bloqué
10 pcs	A2C59510121	black	12/24 V	single	0 mph	120 mph	-	-	no bezel	no bezel	Inductive, Hall, Oscillateur bloqué
10 pcs	A2C59510122	black	12/24 V	double	0 mph	60 mph	0 km/h	95 km/h	no bezel	no bezel	Inductive, Hall, Oscillateur bloqué
10 pcs	A2C59510123	black	12/24 V	double	0 mph	85 mph	0 km/h	140 km/h	no bezel	no bezel	Inductive, Hall, Oscillateur bloqué
10 pcs	A2C59510124	black	12/24 V	double	0 mph	140 mph	0 km/h	220 km/h	no bezel	no bezel	Inductive, Hall, Oscillateur bloqué
10 pcs	A2C59510125	black	12/24 V	double	0 mph	220 mph	0 km/h	360 km/h	no bezel	no bezel	Inductive, Hall, Oscillateur bloqué

1.1.2 GPS Speed

This multifunctional gauge with segment display is intended for use in the marine market in open boats.

Based on the ViewLine housing concept, the cluster provides an ideal IP protection class, a modern appearance and high quality standards. It provides many parameters in NMEA 2000® and there are several customization opportunities to meet specific customer demands.

Features

- Easy installation Plug&Play.
- Embedded GPS antenna.
- Robust and flexible design for versatile applications.
- CAN capability (NMEA 2000®).
- Pointer for analog indication of Speed over Ground (SOG).
- Programmable speed alarm.
- Fixed segment LC display.
- Flush mount possibility.
- Front side protection rating IP67.
- Compass for Course over Ground (COG).
- Clock.
- 110 mm installation diameter.
- 126 mm outer diameter.
- 50 mm installation depth.



GPS speed, gauge range 0 to 35 knots / kmh / mph.



GPS speed, gauge range 0 to 70 knots / kmh / mph.

Aftermarket package:

GPS speed gauge, GPS speed cable, Round bezel, Pushbuttons for mode and configuration, Spinlock nut, Rubber seal, QR code, Safety instructions.

Part number	Range knots / kmh / mph	Voltage	Operating temperature
Ø 110 mm			
A2C59501987	0 – 12 knots / kmh / mph	8.5 – 16 V	- 20° / + 85 °C
A2C59501782	0 – 35 knots / kmh / mph	8.5 – 16 V	- 20° / + 85 °C
A2C59501781	0 – 70 knots / kmh / mph	8.5 – 16 V	- 20° / + 85 °C



















Part number	Description
-------------	-------------

ASSOCIATED SENSORS



N03-320-264	Pyrometer - exhaust temperature sensor
323-809-010-005C	Outdoor temperature sensor
X11-719-000-058	NMEA Sensor through-hull
440-102-001-001D	Rudder angle sensor for 1 indicator
440-102-002-001D	Rudder angle sensor for 2 indicators
N02-240-402	Fresh water gauge (capacitive) H = 600 mm
N02-240-404	Fresh water gauge (capacitive) H = 1200 mm
N02-240-406	Fresh water gauge (capacitive) H = 1500 mm
N02-240-902	Single black water gauge 80-600 mm
N02-240-904	Single black water gauge 600-1200 mm
N02-240-906	Single black water gauge 1200-1500 mm
A2C59514041	VL shunt for ammeter 30 A/60 mV
A2C59514043	VL shunt for ammeter 60 A/60 mV
A2C59514045	VL shunt for ammeter 100 A/60 mV
A2C59514047	VL shunt for ammeter 150 A/60mV

ACCESSOIRES

Image	Item specifics	Part number
	Spinlock nut 52 mm	A2C52059471
	Spinlock nut 85 mm	A2C53212238
	Spinlock nut 110 mm	A2C53238881
	Pushbutton for LCD 13.6 mm IP67	A2C59512684
	Connector set 8 pin	A2C59510850
	Connector set 14 pin	A2C59510851
	Adapter cable for 52 mm 5 x AMP taps, 6.3 mm 2 x AMP taps, 2.8 mm	A2C59510852
	Make Point Switch 12 V, Gauges: 52 mm: temperature, pressure, tank, trim, rudder angle 85/110 mm: temperature, pressure, tank	A2C59510886
	Adapter cable 8-pole for temperature, pressure, fuel level, trim, pyrometer, outside temperature, fresh water, blackwater, tachometer, speedometer	A2C59512947
	Adapter cable 8 pole for voltmeter, engine hours counter, clock	A2C59512948
	Adapter cable 14 pole for tachometer with LCD	A2C59512950
	GPS Speed cable	A2C95822600
	Connector protective cap 8 pole	A2C53324664
	Connector protective cap 14 pole	A2C53324671
	Connector blind plug 14 pin	A2C59513492
	Dropping Resistor 24 V (without connector)	A2C59510221
	Dropping Resistor 24 V (with connector)	A2C59510853
	Bracket assembly mounting set	A2C59510854
	Flush mount fixing bracket	A2C59510864
	Software cable	A2C59514543

BEZELS

Profile	Color	Article number
Ø 52 MM		
FLAT	Black	A2C53186040
	White	A2C53186022
	Chrome	A2C53186023
TRIANGULAR	Black	A2C53186024
	White	A2C53186025
	Chrome	A2C53186026
ROUND	Black	A2C53186027
	White	A2C53186028
	Chrome	A2C53186029
Ø 85 MM		
FLAT	Black	A2C53192911
	White	A2C53192912
	Chrome	A2C53192910
TRIANGULAR	Black	A2C53192917
	White	A2C53192920
	Chrome	A2C53192918
ROUND	Black	A2C53192913
	White	A2C53192916
	Chrome	A2C53192914
Ø 110 MM		
FLAT	Black	A2C53210745
	White	A2C53210746
	Chrome	A2C53210747
TRIANGULAR	Black	A2C53210763
	White	A2C53210764
	Chrome	A2C53210765
ROUND	Black	A2C53210749
	White	A2C53210760
	Chrome	A2C53210761



Bezels in chrome, black and white.



Warning Gauges

Gauges to indicate Warnings for Engine and Cabin Control.

Features





































- LED Illumination.
- Backlit Technology.
- Changeable bezels.
- Antifog and splash protection.
- Panel and Flush mount technology.
- Available in a big amount of variants.



Technical Data

Installation depth	50mm
Installation diameter	52mm
Operating Voltage	8 – 16 Volt
Operating Voltage	20mA pro Warning lamp
Current consumption	250mCd (pro LED)
Operating temperature	-20°C to +70°C
Storage temperature	-30°C to +80°C for 48h; plated bezel (chrome) -30°C to +70°C
EMC in conformity with (Electromagnetic compatibility)	DIN_EN 61000-6-2:2006-03 DIN_EN 61000-6-3:2011-09
Standards	CE
Vibration	ISO 16750-3 § 4.1.2.4
Temperature	ISO 16750-4 § 5.3.1 ISO 16750-4 § 5.2
Protection class	according to IEC 60529 Front: IP67 (in nominal position) Rear: IP52 (in nominal position)

Basic variants without bezel

	A2CFR017001	A2CFR017002	A2CFR017004	A2CFR017005	A2CFR017006	A2CFR017008
Application	Engine Control	Engine Control	Cabin Control	Engine Control Marine	Engine Control Marine	Engine Control Agri and Constr.
Packaging	10 pc	10 pc	10 pc	10 pc	10 pc	10 pc
Voltage	12 Volt	12 Volt	12 Volt	12 Volt	12 Volt	12 Volt
Dial	White	Black	Black	White	Black	Black
Buzzer	Yes	Yes	No	No	No	No
Bezel	No	No	No	No	No	No
ISO Symbol No.1						
Color No.1	yellow	yellow	green	yellow	yellow	yellow
Activation No.1	TRM. 31 Ground	TRM. 31 Ground	+12 Volt	TRM. 31 Ground	TRM. 31 Ground	TRM. 31 Ground
ISO Symbol No.2						
Color No.2	red	red	blue	red	red	red
Activation No.2	TRM. 31 Ground	TRM. 31 Ground	+12 Volt	TRM. 31 Ground	TRM. 31 Ground	TRM. 31 Ground
ISO Symbol No.3						
Color No.3	red	red	yellow	red	red	red
Activation No.3	TRM. 31 Ground	TRM. 31 Ground	+12 Volt	TRM. 31 Ground	TRM. 31 Ground	TRM. 31 Ground
ISO Symbol No.4						
Color No.4	red	red	red	red	red	red
Activation No.4	TRM. 31 Ground	TRM. 31 Ground	+12 Volt	TRM. 31 Ground	TRM. 31 Ground	TRM. 31 Ground
ISO Symbol No.5						
Color No.5	red	red	green	red	red	red
Activation No.5	TRM. 31 Ground	TRM. 31 Ground	+12 Volt	TRM. 31 Ground	TRM. 31 Ground	TRM. 31 Ground
ISO Symbol No.6						
Color No.6	green	green	red	yellow	yellow	yellow
Activation No. 6	+12 Volt or TRM. 31 Ground	+12 Volt or TRM. 31 Ground	+12 Volt or TRM. 31 Ground	+12 Volt or TRM. 31 Ground	+12 Volt or TRM. 31 Ground	+12 Volt or TRM. 31 Ground

Aftermarket variants with bezel

	A2C59506150	A2C59506153	A2C59506155	A2C59506154	A2C59506156	A2C59506159	A2C59506160	A2C59506161
Application	Engine Control (Basic A2CFR017001)	Engine Control (Basic A2CFR017002)	Cabin Control (Basic A2CFR017004)	Cabin Control (Basic A2CFR017004)	Engine Control Marine (Basic A2CFR017005)	Engine Control Marine (Basic A2CFR017006)	Engine Control Agri and Constr. (Basic A2CFR017008)	Engine Control Agri and Constr. (Basic A2CFR017008)
Packaging	1 pc Aftermarket	1 pc Aftermarket	1 pc Aftermarket	1 pc Aftermarket	1 pc Aftermarket	1 pc Aftermarket	1 pc Aftermarket	1 pc Aftermarket
Voltage	12 Volt	12 Volt	12 Volt	12 Volt	12 Volt	12 Volt	12 Volt	12 Volt
Dial	White	Black	Black	Black	White	Black	Black	Black
Buzzer	Yes	Yes	No	No	No	No	No	No
Bezel	Triangle chrome	Triangle black	Triangle black	Triangle chrome	Round white	Round black	Triangle chrome	Triangle black
ISO Symbol No.1								
Color No.1	yellow	yellow	green	green	yellow	yellow	yellow	yellow
Activation No.1	TRM. 31 Ground	TRM. 31 Ground	+12 Volt	+12 Volt	TRM. 31 Ground	TRM. 31 Ground	TRM. 31 Ground	TRM. 31 Ground
ISO Symbol No.2								
Color No.2	red	red	blue	blue	red	red	red	red
Activation No.2	TRM. 31 Ground	TRM. 31 Ground	+12 Volt	+12 Volt	TRM. 31 Ground	TRM. 31 Ground	TRM. 31 Ground	TRM. 31 Ground
ISO Symbol No.3								
Color No.3	red	red	yellow	yellow	red	red	red	red
Activation No.3	TRM. 31 Ground	TRM. 31 Ground	+12 Volt	+12 Volt	TRM. 31 Ground	TRM. 31 Ground	TRM. 31 Ground	TRM. 31 Ground
ISO Symbol No.4								
Color No.4	red	red	red	red	red	red	red	red
Activation No.4	TRM. 31 Ground	TRM. 31 Ground	+12 Volt	+12 Volt	TRM. 31 Ground	TRM. 31 Ground	TRM. 31 Ground	TRM. 31 Ground
ISO Symbol No.5								
Color No.5	red	red	green	green	red	red	red	red
Activation No.5	TRM. 31 Ground	TRM. 31 Ground	+12 Volt	+12 Volt	TRM. 31 Ground	TRM. 31 Ground	TRM. 31 Ground	TRM. 31 Ground
ISO Symbol No.6								
Color No.6	green	green	red	red	yellow	yellow	yellow	yellow
Activation No. 6	+12 Volt or TRM. 31 Ground	+12 Volt or TRM. 31 Ground	+12 Volt or TRM. 31 Ground	+12 Volt or TRM. 31 Ground	+12 Volt or TRM. 31 Ground	+12 Volt or TRM. 31 Ground	+12 Volt or TRM. 31 Ground	+12 Volt or TRM. 31 Ground

1.1.2 International Cockpit

Robust instruments designed for heavy use conditions

Each instrument is supplied complete, ready to be mounted with lighting (except in specific cases). Detailed range below.

- Black dial with white scale or white with black scale, and ISO symbols.
- Black triangular bezel.
- Light diffusion.
- Anti-reflective glass.
- Power supply: 12 V (11 to 16 V) and/or 24 V (21,5 to 30 V).
- Operating temperature: -30 to +85°C.
- Fixing by bracket or clamp ring.
- Protection class: IP64.



Speedometer

- Analog display of speed (needle).
- Digital display totalizer (km) and tripmeter (liquid crystal display).
- Totalizer 7 character (up to 999 999.9).
- Tripmeter 5 characters (up to 9 999.9).
- Number of pulses to the programmable km (500 to 400 000 pulses).
- Signal source: Hall sensors, inductive sensors or blocked oscillators.
- Supplied with mounting bracket.
- The instrument can also be fitted with a clamping ring (order separately).
- Power supply: 12 V and 24 V.
- Black dial.

Packaging	Part number	Scale	Installation Ø	Voltage
ELECTRONIC SPEEDOMETER				



10 pcs	437-035-001C	0 - 60 km/h	80 mm	12 V
single	437-035-001G	0 - 60 km/h	80 mm	12 V
10 pcs	437-035-002C	0 - 120 km/h	80 mm	12 V
single	437-035-002G	0 - 120 km/h	80 mm	12 V
10 pcs	437-035-003C	0 - 200 km/h	80 mm	12 V
single	437-035-003G	0 - 200 km/h	80 mm	12 V
6 pcs	437-025-002C	0 - 125 km/h	140 mm	24 V

Tachometer

- For gasoline or diesel.
- Programmable for gasoline engines (4, 6 or 8 cylinders) and for diesel engines (making the information on terminal W).
- Supplied with mounting bracket. The instrument can be mounted with fixing ring (to be ordered separately).
- Power supply: see above table.
- Black dial.

Packaging	Part number	Scale	Installation Ø	Voltage
ELECTRONIC TACHOMETER				



single	333-035-029G	0 - 4000 tr.min-1	52 mm	12 V
10 pcs	333-035-017C	0 - 6000 tr.min-1	52 mm	12 V
single	333-035-017G	0 - 6000 tr.min-1	52 mm	12 V
single	333-035-018G	0 - 8000 tr.min-1	52 mm	12 V
10 pcs	333-035-001C	0 - 3000 tr.min-1	80 mm	12 V
single	333-035-001G	0 - 3000 tr.min-1	80 mm	12 V
10 pcs	333-045-001C	0 - 3000 tr.min-1	80 mm	24 V
single	333-045-001G	0 - 3000 tr.min-1	80 mm	24 V
10 pcs	333-035-002C	0 - 4000 tr.min-1	80 mm	12 V
single	333-035-002G	0 - 4000 tr.min-1	80 mm	12 V
10 pcs	333-045-002C	0 - 4000 tr.min-1	80 mm	24 V
single	333-045-002G	0 - 4000 tr.min-1	80 mm	24 V
single	333-035-003G	0 - 7000 tr.min-1	80 mm	12 V
10 pcs	333-035-022C	0 - 10000 tr.min-1	80 mm	12 V
single	333-035-022G	0 - 10000 tr.min-1	80 mm	12 V
single	333-055-001G	0 - 3000 tr.min-1	100 mm	12 V
single	333-065-001G	0 - 3 000 tr.min-1	100 mm	24 V

Tachometer

- Programmable for almost all combinations “x cylinders / x strokes.”
- Analog display of engine speed (needle).
- Digital display (LCD) of the operating hours of 7 characters (up to 99 999.9 h).
- For vehicles with 12V or 24V power socket information: W terminal, Hall effect sensors, sensor proximity switches, locked oscillators, terminal 1 or alternator tachometer.
- Supplied with mounting bracket.
- The instrument can also be fitted with a clamping ring (order separately).
- Power supply: 12 V and 24 V.
- Black dial.

Packaging	Part number	Scale	Installation Ø	Voltage
-----------	-------------	-------	-------------------	---------

ELECTRONIC TACHOMETER



single	333-035-010G	0 - 3000 tr.min-1	80 mm	12 V
10 pcs	333-035-010C	0 - 3000 tr.min-1	80 mm	12 V
single	333-035-011G	0 - 4000 tr.min-1	80 mm	12 V
10 pcs	333-035-011C	0 - 4000 tr.min-1	80 mm	12 V
10 pcs	333-035-014C	0 - 6000 tr.min-1	80 mm	12 V
single	333-055-002G	0 - 3000 tr.min-1	100 mm	12 V
10 pcs	333-055-002C	0 - 3000 tr.min-1	100 mm	12 V

Temperature meter

- For all types of vehicles and industrial equipment.
- Allows the reading of engine oil temperatures, transmission oil, coolant and hydraulic oil.
- Black dial.

Packaging	Part number	Scale	Installation Ø	Voltage
-----------	-------------	-------	-------------------	---------

COOLING LIQUID TEMPERATURE WITH ISO SYMBOL



single	310-030-002G	40 – 120°C	52 mm	12 V
10 pcs	310-030-002C	40 – 120°C	52 mm	12 V
single	310-040-002G	40 – 120°C	52 mm	24 V
10 pcs	310-040-002C	40 – 120°C	52 mm	24 V
10 pcs	310-030-020C	40 – 120°C/100-250F°	52 mm	12 V
10 pcs	310-040-020C	40 – 120°C/100-250F°	52 mm	24 V

ENGINE OIL TEMPERATURE WITH ISO SYMBOL



single	310-030-003G	50 – 150°C	52 mm	12 V
10 pcs	310-030-003C	50 – 150°C	52 mm	12 V
single	310-040-003G	50 – 150°C	52 mm	24 V
10 pcs	310-040-003C	50 – 150°C	52 mm	24 V

Temperature meter

Packaging	Part number	Scale	Installation Ø	Voltage
HYDRAULIC OIL TEMPERATURE WITH ISO SYMBOL				

single	310-030-013G	40 – 120°C	52 mm	12 V
10 pcs	310-030-013C	40 – 120°C	52 mm	12 V
single	310-040-013G	40 – 120°C	52 mm	24 V
10 pcs	310-040-013C	40 – 120°C	52 mm	24 V

Packaging	Part number	Scale	Installation Ø	Voltage
TRANSMISSION OIL TEMPERATURE WITH ISO SYMBOL.				



single	310-030-015G	50 – 150°C	52 mm	12 V
10 pcs	310-030-015C	50 – 150°C	52 mm	12 V
single	310-040-015G	50 – 150°C	52 mm	24 V
10 pcs	310-040-015C	50 – 150°C	52 mm	24 V

TEMPERATURE OF THE AIR-COOLED ENGINES WITHOUT ISO SYMBOL

single	310-030-004G	60 – 200°C	52 mm	12 V
10 pcs	310-030-004C	60 – 200°C	52 mm	12 V
single	310-040-004G	60 – 200°C	52 mm	24 V
10 pcs	310-040-004C	60 – 200°C	52 mm	24 V

PYROMETER

single	397-015-003C	0 – 900°C	52 mm	
--------	---------------------	-----------	-------	--

Pressure indicator

Packaging	Part number	Scale	Installation Ø	Voltage
ENGINE OIL PRESSURE WITH ISO SYMBOL				



single	350-030-003G	0 - 5 bar	52 mm	12 V
10 pcs	350-030-003C	0 - 5 bar	52 mm	12 V
single	350-030-004G	0 - 10 bar	52 mm	12 V
10 pcs	350-030-004C	0 - 10 bar	52 mm	12 V
single	350-040-003G	0 - 5 bar	52 mm	24 V
10 pcs	350-040-003C	0 - 5 bar	52 mm	24 V
single	350-040-004G	0 - 10 bar	52 mm	24 V
10 pcs	350-040-004C	0 - 10 bar	52 mm	24 V

Packaging	Part number	Scale	Installation Ø	Voltage
BRAKE PRESSURE WITH ISO SYMBOL				



single	350-040-011G	0 - 10 bar	52 mm	24 V
--------	---------------------	------------	-------	------

- For all types of vehicles and industrial equipment.
- Black dial.

Packaging	Part number	Scale	Installation Ø	Voltage
TRANSMISSION OIL PRESSURE WITH ISO SYMBOL				



single	350-030-005G	0 - 25 bar	52 mm	12 V
single	350-040-005G	0 - 25 bar	52 mm	24 V
10 pcs	350-040-005C	0 - 25 bar	52 mm	24 V

Fuel level indicator

- Available in 2 versions (lever sensors or tubular sensors).

Packaging	Part number	Scale	Installation Ø	Voltage
FUEL LEVEL INDICATOR FOR LEVER SENSORS				



10 pcs	301-030-001C	0 - 1/1	52 mm	12 V
single	301-030-001G	0 - 1/1	52 mm	12 V
10 pcs	301-040-001C	0 - 1/1	52 mm	24 V
single	301-040-001G	0 - 1/1	52 mm	24 V

External temperature indicator

- For all types of vehicles and industrial equipment.
- Supplied with mounting bracket.
- The instrument can also be fitted with a clamping ring (order separately).
- Power supply: 12 V.
- Black dial.
- Outside temperature indicators are always equipped with 12V bulbs.

Packaging	Part number	Scale	Installation Ø	Voltage
EXTERNAL TEMPERATURE				



single	397-035-001G	- 25°C à + 40°C	52 mm	12 V
--------	---------------------	-----------------	-------	------

 For applications 24V bulbs must be ordered separately.

Ammeter

- Operates independently of the vehicle power supply voltage.
- Comes with mounting bracket, without lighting.
- Black or white dial.

Packaging	Part number	Scale	Installation Ø	Voltage
-----------	-------------	-------	-------------------	---------

AMMETER



single	190-037-002G	60 - 0 - 60 A	52 mm	
10 pcs	190-037-002C	60 - 0 - 60 A	52 mm	
single	190-037-003G	100 - 0 - 100 A	52 mm	
10 pcs	190-037-003C	100 - 0 - 100 A	52 mm	

Voltmeter

- For all types of vehicles and industrial equipment.
- Black or white dial.

Packaging	Part number	Scale	Installation Ø	Voltage
-----------	-------------	-------	-------------------	---------

VOLTMETER



single	332-030-001G	8 - 16 V	52 mm	12 V
10 pcs	332-030-001C	8 - 16 V	52 mm	12 V
single	332-040-001G	18 - 32 V	52 mm	12 V
10 pcs	332-040-001C	18 - 32 V	52 mm	12 V

Hour counter

- For all types of vehicles and industrial equipment.
- Display up to 99999.9 h.
- Power supply: 12 V or 24 V.
- No internal light.
- Supplied with mounting bracket.
- The instrument can also be fitted with a clamping ring (order separately).
- Black dial.

Packaging	Part number	Scale	Installation Ø	Voltage
-----------	-------------	-------	-------------------	---------

ELECTRONIC HOUR COUNTER



single	331-810-012-001G	w/o illumination, black	52 mm	12 V
10 pcs	331-810-012-001B	w/o illumination, black	52 mm	12 V
single	331-810-012-007G	w/o illumination, black	52 mm	24 V
20 pcs	331-810-012-007B	w/o illumination, black	52 mm	24 V
single	331-810-012-002G	w/o illumination, black	52 mm	12 V
20 pcs	331-810-012-002B	w/o illumination, black	52 mm	12 V

Clock

- For all types of vehicles and industrial equipment.
- Setting the time by stepping motor.
- Supplied with mounting bracket.
- The instrument can also be fitted with a clamping ring (order separately).
- Black dial.

Packaging	Part number	Scale	Installation Ø	Voltage
-----------	-------------	-------	-------------------	---------

CLOCK



single	370-214-031-001G			12 V
single	370-214-031-003G			24 V

Mechanical pressure indicator

- It does not require power supply.
- Fitting 12x1,5.
- Delivered without illumination (order separately).
- Black dial.

Packaging	Part number	Scale	Installation Ø	Voltage
-----------	-------------	-------	-------------------	---------

MECHANICAL PRESSURE INDICATOR



single	150-035-001G	-1 - 1,5 bar	52 mm	
single	150-035-004G	0 - 7 bar	52 mm	
single	150-035-006G	0 - 10 bar	52 mm	
single	150-035-025G	0 - 10 bar	52 mm	
single	150-035-009G	0 - 30 bar	52 mm	
single	150-035-020G	0 - 10 x100kPa	52 mm	



1.1.3 Customer-Specific Solutions

In addition to the standard range, the new Viewline instruments also offer OEMs the opportunity to implement solutions to meet their own specific requirements.

Multifunction instruments*

Complementing our tried and tested standard solutions, the Viewline range now also offers the option of multifunction instruments:

- Integration of up to four display gauges in a single 110 mm instrument.
- Choose exactly the gauges required.
- Integration of up to five warning lights.

Generic gauges

The advanced technology used in Viewline makes it possible to process and display a wide variety of sensor sources and mappings, e.g.:

- Current and resistor inputs.
- Frequency inputs.
- Voltage inputs.

Combi-instruments*

Using a second optional frequency input, the combi-instrument can present speedometer and tachometer information in either analog (dial) or digital form (display). Optionally available for:

- 85 mm instruments.
- 110 mm instruments.

*On request



1.1.4 Modulcockpit II

Versatile and adaptable

VDO Modulcockpit II is a modular system designed with real-world requirements in mind that can be adapted for many different types of applications. The instruments in this series can be installed in any combination with a choice of dual- or quad-instrument housings. Transmitted light technology enables the best possible contrast, even at night. The housings are made of rugged black plastic with low-reflection, scratch-resistant lenses.

VDO Modulcockpit II can be connected quickly and easily via a central connector. Available in 12 and 24 volt versions, it is equally suitable for both on-road and off-road use.



Modulcockpit II:
Dual- and quad-instrument housings in rugged plastic allow flexible combinations of instruments

1.1.4.a | Dual-Instrument Units - Vertical

Part Number	Voltage	Graphics overlay 84-438-532-00 ...			
		Item 1	Item 2	Item 3	Item 4

Indicator lights /
Engine hours counter

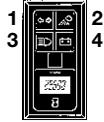

110-008-984-001G	12 V		31		04		08		09
------------------	------	--	----	--	----	--	----	--	----

Part Number	Voltage	Single system							
-------------	---------	---------------	--	--	--	--	--	--	--

Single system /
operating hours
counter



Lever-arm sender



Tubular sender

110-008-983-005C	12 V	Level indicator	301-291-980-003C						
------------------	------	-----------------	------------------	--	--	--	--	--	--

Part Number	Voltage	Single system I				Single system II			
-------------	---------	-----------------	--	--	--	------------------	--	--	--

Single system /
single system

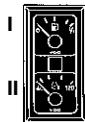

Lever-arm sender



Tubular sender

110-008-981-014C	24 V	301-292-980-004C			310-284-980-011C		120 °C		
------------------	------	------------------	--	--	------------------	--	--------	--	--

Part Number	Voltage	Graphics overlay 84-438-532-00 ...				Single system I
		Item 1	Item 2	Item 3	Item 4	

Indicator lights /
Single system

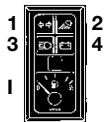

110-008-982-004C	12 V		08		09		40		10	310-284-980-011C	120 °C	
------------------	------	--	----	--	----	--	----	--	----	------------------	--------	--

110-008-982-005C	12 V		01		02		04		07	301-291-980-003C		
------------------	------	--	----	--	----	--	----	--	----	------------------	--	--

Part Number	Voltage	Graphics overlay 84-438-532-00 ...							
		Item 1	Item 2	Item 3	Item 4	Item 5	Item 6	Item 7	Item 8

Indicator lights /
indicator lights

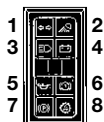

Tubular sender

113-000-980-002G	24 V		01		06		07		08		09		10		11		13
------------------	------	--	----	--	----	--	----	--	----	--	----	--	----	--	----	--	----

113-000-980-004C	24 V	Without graphics overlay															
------------------	------	--------------------------	--	--	--	--	--	--	--	--	--	--	--	--	--	--	--

113-000-980-014C	12 V		01		02		07		06		08		10		09		31
------------------	------	--	----	--	----	--	----	--	----	--	----	--	----	--	----	--	----

1 discontinued (but still available)

1.1.4.b Dual-Instrument Units - Horizontal

Part Number	Voltage	Graphics overlay 84-438-532-00 ...							
		Item 1	Item 2	Item 3	Item 4	Item 5	Item 6	Item 7	Item 8

Indicator lights /
indicator lights

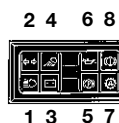

Lever-arm sender



Tubular sender

113-000-980-004C	24 V	Without graphics overlay							
------------------	------	--------------------------	--	--	--	--	--	--	--

1.1.4.c | Quad-Instrument Units

Part Number	Voltage	Item	Single system		Item	Single system	
-------------	---------	------	---------------	--	------	---------------	--

4x
single system



Lever-arm sender

110-008-980-013C	24 V	I	301-292-980-004C		III	310-284-980-011C	120 °C	
		II	332-305-980-004C	32 V	IV	350-272-980-011C	0 bar	

1.1.4.d | Tachometer with Engine Hours Counter

OVERVIEW OF INSTRUMENTS		
Part Number	Measuring range	2 socket lamps
333-251-980-003C	0-3,000 min-1	24 volts, 1.2 watts
333-251-980-004C	0-4,000 min-1	24 volts, 1.2 watts

1.1.4.e | Electronic Speedmeter

OVERVIEW OF INSTRUMENTS		
Part Number	Measuring Range	Special Features
437-260-980-001C	0-60 km/h, 0-37 MPH	-
437-809-980-004C	0-60 km/h, 0-37 MPH	with PWM output (speed signal)
437-260-980-002C	0-125 km/h, 0-77 MPH	-
437-809-980-005C	0-125 km/h, 0-77 MPH	with PWM output (speed signal)

ACCESSORIES	
Part Number	Description
X11-000-014-001	Modul 4pin connector
X11-000-014-002	Modul 5pin connector
X11-000-014-003	Modul 7pin connector
X11-000-014-004	Modul 8pin connector
X11-725-002-008	D'mac 10pin connector
X11-000-014-005	Modul 1 pin (Minimum order quantity 1000 Pz)



1.2 Analog Clusters*

1.2.1 Centrobases 500

* Only available for series production applications on request

Centrobases 500

The Centrobases 500 instrument clusters allow all relevant engine data (analog and digital) to be presented clearly on a central display, thus enabling greater convenience and enhanced ergonomics in the driver's cab. Centrobases 500 is continuously adapted and updated to meet customer requirements.

Dials can be adapted to meet individual customer requirements in terms of scaling, icons, and design.

Our Centrobases 500 instrument stands out for their efficiency, flexibility, quality, reliability, and ease of use.

1.2.1 Centrobases 500

CENTROBASE 500	
Part Number	Description
A2C59212186	Analog display



Description:

- Analogue display of engine speed, vehicle speed, temperature and fill level; battery voltage and pressure available as options.
- Digital display: choice of operating hours, total mileage, trip counter, trip operating hours, time of day, and current gear.
- Display includes up to 15 indicator lights.
- Self-test for 5 indicator lights.
- Programming via diagnostics interface (K-line).

CENTROBASE 500 ACCESSORIES	
Part Number	Description

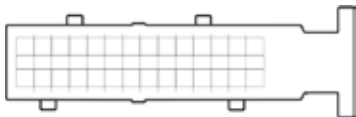

A2C53117228	Socket housing
-------------	----------------



A2C53117260	Socket contact
-------------	----------------



A2C53117261	Socket contact
-------------	----------------



1.3 CAN Instruments*

- 1.3.1 CANcockpit
- 1.3.2 Ocean Link
- 1.3.3 Accessories
- 1.3.4 Centrobases 350/400
- 1.3.5 Flex Cluster

* Only for trained partners

1.3.1 CANcockpit*

Handle complex requirements with ease.

The VDO brand is synonymous with customised solutions that handle sophisticated technical tasks while offering maximum ease of operation. VDO products are deployed in a wide range of applications from construction vehicles, agricultural and forestry equipment to stationary machines, sports cars and boats.

CANcockpit is the flexible system solution for processing data from various analogue and digital sensors via a central instrument connected to a CANbus.

It can be precision configured to meet specific needs, and is simple to expand whenever required. In addition, this modular instrumentation solution may be integrated into existing VDO panel solutions. Thanks to the powerful WINgauge software it is exceptionally easy to program. CANcockpit is also capable of processing two CAN protocols (e.g. SAE J1939 and CANopen) simultaneously.

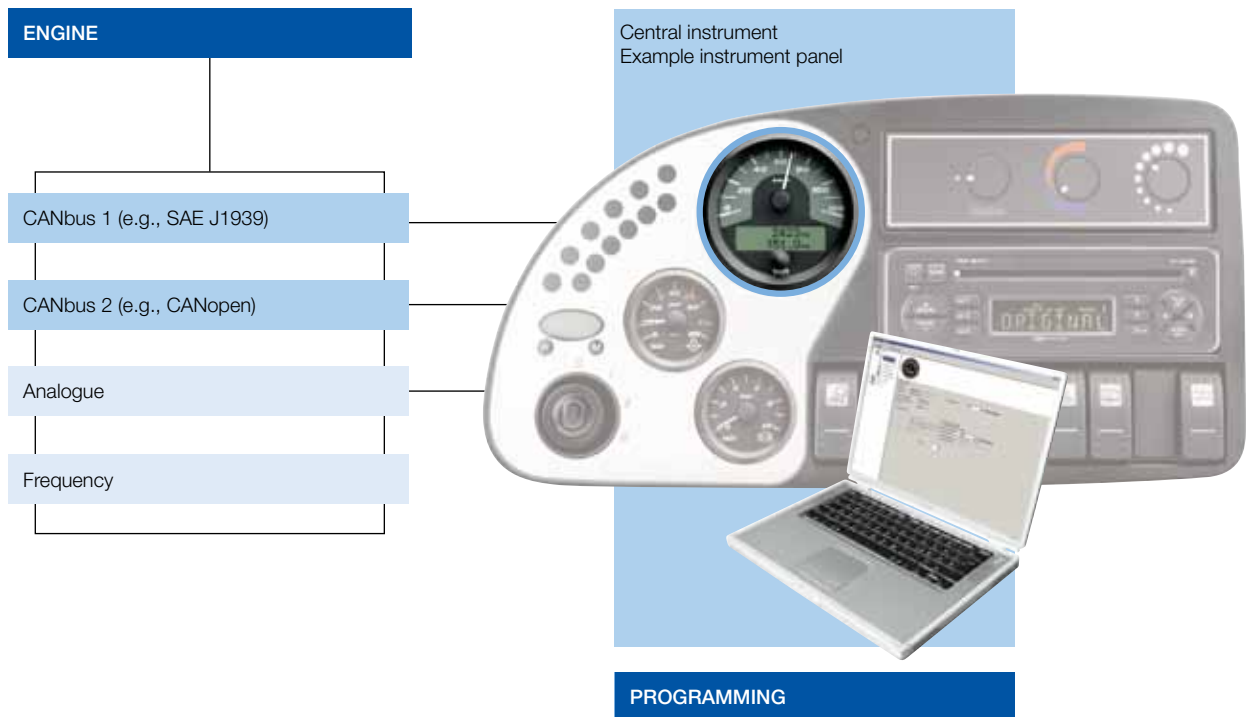

* Only for trained partners

CANcockpit - harness the benefits.

- **Flexibility** - Data from up to two CANbuses running different protocols (e.g. SAE J1939 and CANopen) can be processed simultaneously.
- **Safety** - Easy DTC (diagnostic trouble code) handling of the protocol defined by J1939 through comprehensive functionality and setting options.
- **Diagnostic support** - Configuration checking, plus online recording of selected measurement values via recorder function for subsequent download onto PC and evaluation using standard tools.
- **Compatibility** - Analogue, frequency and CAN inputs are available.
- **Integration** - CANcockpit can easily be incorporated into existing VDO panel solutions.
- **Configurability** - Specific thresholds can be set and programmed so that an alarm triggers when they are exceeded.
- **Modularity** - Simple cabling requirements and straightforward subsequent expansion.
- **Convenience** - Automatic plausibility check for the parameters entered and various functional checks carried out by special WINgauge software during input phase.
- **Customization** - Flexible LC-display options allow icons to be defined and corporate logos to be displayed.
- **Readability** - Instrumentation designed for maximum clarity.

Up to 16 instruments can be controlled by a central instrument. Integration into VDO panel solutions can be carried out easily.

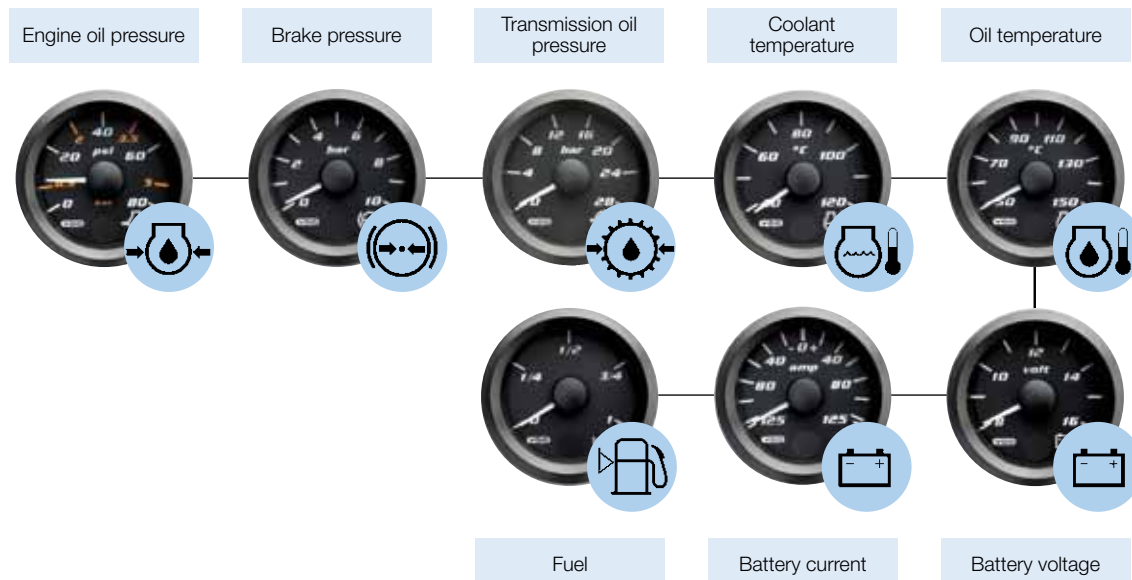

Variable configuration options.

CANcockpit, the flexible solution for a wide range of applications, offers numerous configuration and expansion options. It is based around a central instrument which can be either a tachometer or a speedometer. The central instrument features two CAN inputs supporting different CAN protocols, two frequency inputs,

three resistive inputs, one 4 - 20 mA input, plus one 0 - 5 V input. In addition, it is equipped with two switched outputs, a configurable digital display field, and more.

Three sample standard applications are shown below:

Basic configuration

Sample requirement:

A generator is to be fitted with a tachometer measuring up to 3,000 rpm. There is only one CANbus; the threshold values and settings are clearly defined.

CANcockpit provides the solution:

Once the tachometer has been set up as the central instrument you will have access to the desired tachometer display and the option of viewing other data, e.g. as part of an inspection routine, as and when required. All data can be displayed on the central instrument, allowing you to monitor current engine data at any time without the need for other satellite instruments.

Standard configuration

Sample requirement:

Instrumentation for a digger is one example of a standard configuration using CANcockpit. A tachometer and four more instruments need to be added to a CANbus.

CANcockpit provides the solution:

Once the instrumentation solution has been programmed (a simple procedure), key engine data such as coolant/engine oil/transmission oil temperatures will be displayed alongside rpm and operating hours, plus fuel level - giving you a clear overview of crucial information at all times.

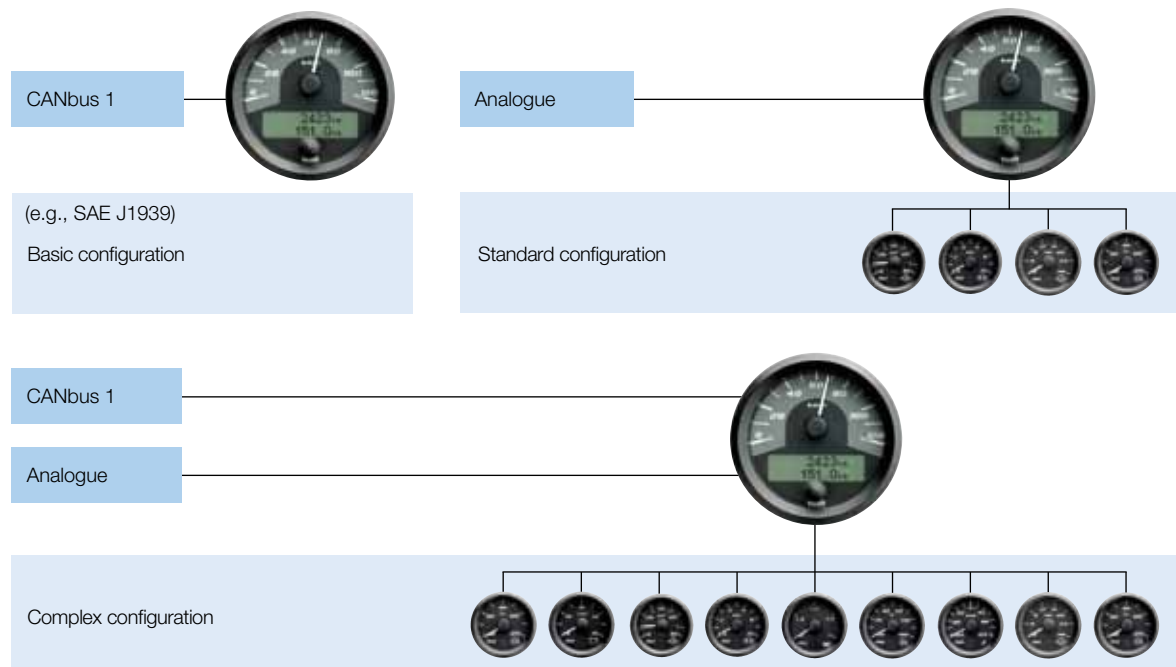

Complex configuration

Sample requirement:

Rigorous safety requirements and different vehicle deployment scenarios (construction sites and public roads) often require complex configurations. One example is a mobile crane, the central instrument of which is to be hooked up to manage nine more instruments. All data comes from analogue sensors and frequency sensors via a CANbus.

CANcockpit provides the solution:

CANcockpit can cover even this complex configuration with ease. The instruments are connected and set, allowing a wide range of physical engine data to be displayed at all times, as well as e.g. hydraulic data (CANopen). For you, this means maximum choice when it comes to putting together the required display instruments.

Technical data

Movement	Stepper motor
Installation diameter [mm]	Central instrument 80, 85, 100; satellite instruments 52, 80, 100
Illumination	Transmitted light, LED, white as standard
Protection rating	IP65 IEC 60.529, front side
Front lens	Glass, anti-reflective
Bezel	Plastic, black, triangular as standard Options (not yet available): Triangular profile in chrome, round profile in black
Connectors	Central instrument: Mate-N-Lok 4-pin and MODU II 26-pin Satellite instruments: Mate-N-Lok 6-pin
Viewing angle	Approx 210° for central instrument, 240° for satellite instruments
Warning lights	In each satellite instrument
CAN inputs	2 x (e.g., SAE J1939, CANopen)
Frequency inputs	1 x Hall, 1 x universal
Analogue inputs	3 x resistors, 1 x 4–20 mA, 1 x 0–5 volts
Outputs	2 x switching outputs, 0.5 A
Operating voltage	12–24 volts (min. 10.5 volts, max. 32 volts)
Installation position	Central instrument no restrictions, satellite instruments 0–85°
Operating temperature	-40 °C ... +85 °C, LCD has limited readability below -20 °C and above +70 °C
Storage temperature	-40 °C ... +85 °C

For further information about VDO, please visit our website: www.vdo.com

WINgauge - flexible configuration software

WINgauge has been specially developed for CANcockpit. This software enables the convenient and flexible configuration of individual instruments or a complete series of instruments. In addition to maximum functionality and customisable programming, WINgauge offers maximum ease of operation.

VDO also offers training to help you program a CANcockpit solution. This training tells users everything they need to know about the innovative features, such as how to personalise the system and integrate corporate logos and symbols into the central instruments display.



Selecting the central instrument and basic settings



Setting the basic CAN settings (if applicable)



Sensor database and mapping adjustments for optimum performance



Setting warnings and alarms including choice of response and priorities



DTC handling and personal configuration with individual messages and symbols



Programming of requests, e.g. query operating hours



Adding satellite instruments



Adding display gauges

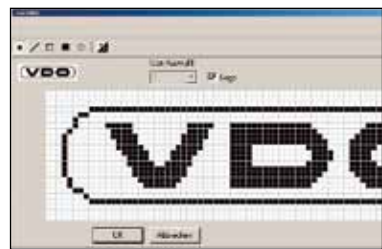

Programming the central instrument, e.g. with a proprietary logo or symbol



The individual project is now programmed

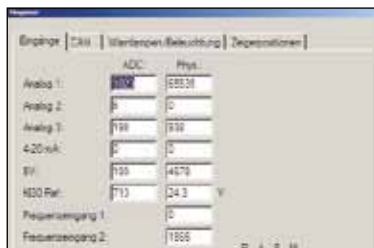

Numerous diagnostic options are available

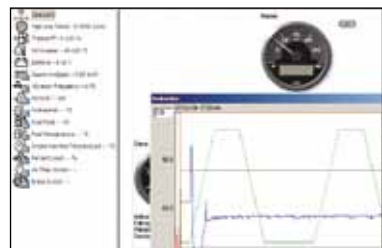

Capturing, storing and processing selected data by connecting to a PC

VDO CANcockpit is a flexible system solution for processing data from various analogue and digital sensors via a master instrument. It can be configured specifically to suit individual requirements and easily expanded or integrated into existing VDO panel solutions whenever required. The instrumentation boasts a modular design

and is particularly easy to program thanks to the powerful WINGauge software. VDO CANcockpit is capable of processing two CAN protocols (e.g. SAE J1939 and CANopen) at the same time, and can control up to 16 instruments via a central instrument.

Part Number	Description
CENTRAL INSTRUMENT 80 MM	
A2C6000020	CCM 80 Tacho 0-3*1000/min S tb
A2C6000021	CCM 80 Tacho 0-4*1000/min S tb
A2C6000022	CCM 80 Speedo 0-60km/h S tb
A2C6000023	CCM 80 Speedo 0-120km/h S tb
A2C6000024	CCM 80 Speedo 0-200km/h S tb
A2C6000025	CCM 80 Speedo 0-80mph D tb
A2C6000026	CCM 80 Speedo 0-30km/h S tb
CENTRAL INSTRUMENT 85 MM	
A2C6000070	CCM 85 Tacho 0-3*1000rpm S tb
A2C6000071	CCM 85 Tacho 0-4*1000rpm S tb
A2C6000072	CCM 85 Speedo 0-120km/h S tb
A2C6000073	CCM 85 Speedo 0-80mph S tb
A2C6000076	CCM 85 Tacho 0-5*1000rpm S tb
CENTRAL INSTRUMENT 100 MM	
A2C60000127	CCM 100 Tacho 0-40*100/min S tb
A2C60000128	CCM 100 Speedo 0-60km/h S tb
A2C60000129	CCM 100 Speedo 0-120km/h S tb
A2C60000130	CCM 100 Speedo 0-200km/h S tb
A2C60000131	CCM 100 Speedo 0-50mph D tb
A2C60000133	CCM 100 Speedo 0-200km/h D tb
A2C60000134	CCM 100 Speedo 0-120mph D tb
BLACK BOX	
A2C60500641	CCM Black Box
SATELLITE INSTRUMENT 52 MM	
A2C60000251	CCS 52 PressOil 0-5bar S tb
A2C60000252	CCS 52 PressOil 0-10bar S tb
A2C60000253	CCS 52 PressOil 0-500kPa S tb
A2C60000254	CCS 52 PressOil 0-1000kPa S tb
A2C60000255	CCS 52 PressOil 0-80psi D tb
A2C60000256	CCS 52 PressOil 0-100psi D tb
A2C60000257	CCS 52 PressOil 0-150psi D tb
A2C60000258	CCS 52 PressBr 0-10bar S tb

Part Number	Description
SATELLITE INSTRUMENT 52 MM	
A2C60000259	CCS 52 PressBr1 0-10bar S tb
A2C60000260	CCS 52 PressBr2 0-10bar S tb
A2C60000261	CCS 52 Press1 0-250bar S wo tb
A2C60000262	CCS 52 Press2 0-250bar S wo tb
A2C60000263	CCS 52 PressBr 0-150psi D tb
A2C60000264	CCS 52 PressBr 0-16bar S tb
A2C60000266	CCS 52 PressTr 0-400psi D tb
A2C60000267	CCS 52 PressTu 0-2bar S tb
A2C60000268	CCS 52 TempOil 50-150C S tb
A2C60000269	CCS 52 TempTr 50-150C S tb
A2C60000270	CCS 52 TempTr 50-150C D tb
A2C60000271	CCS 52 TempTr 120-300F D tb
A2C60000272	CCS 52 Temp 60-200C S wo tb
A2C60000273	CCS 52 TempWa 40-120C S tb
A2C60000274	CCS 52 TempWa 40-120C D tb
A2C60000275	CCS 52 TempWa 100-280F D tb
A2C60000276	CCS 52 TempHy 20-120C S tb
A2C60000278	CCS 52 LevelFuel 0-1 S tb
A2C60000279	CCS 52 LevelFuel E-F S tb
A2C60000280	CCS 52 LevelFw 0-1 S tb
A2C60000281	CCS 52 LevelWw 0-1 S tb
A2C60000282	CCS 52 Volt 8-16V S tb
A2C60000284	CCS 52 Volt 18-32V S tb
A2C60000285	CCS 52 Am -125/+125A S tb
A2C60000286	CCS 52 Tacho 0-3*1000/min S tb
A2C60000287	CCS 52 Speedo 0-60km/h S tb
A2C60000296	CCS 52 RearW L-1/2-0-1/2-R S tb
A2C60000297	CCS 52 PressBr1 0-150psi D tb
A2C60000298	CCS 52 PressBr2 0-150psi D tb
A2C60000299	CCS 52 LevelAdBlue 0-1 S tb
A2C60000354	CCS 52 PressOil 0-10bar S on tb
A2C60000355	CCS 52 TempWa 40-120C S on tb

* Only for trained partners

Bulk package 10-pack	Single package	Description Single Package
A2C60000020	A2C59514364	CCM 80 TACHO 0-3*1000/MIN S tb G
A2C60000021	A2C59514365	CCM 80 TACHO 0-4*1000/MIN S tb G
A2C60000022	A2C59514366	CCM 80 SPEEDO 0-60KM/H S tb G
A2C60000023	A2C59514367	CCM 80 SPEEDO 0-120KM/H S tb G
A2C60000070	A2C59514372	CCM 85 TACHO 0-3*1000 RPM S tb G
A2C60000071	A2C59514373	CCM 85 TACHO 0-4*1000 RPM S tb G
A2C60000076	A2C59514378	CCM 85 TACHO 0-5*1000 RPM S tb G
A2C60000126	A2C59514379	CCM 100 TACHO 0-30*100/MIN S tb G
A2C60000127	A2C59514380	CCM 100 TACHO 0-40*100/MIN S tb G
A2C60000129	A2C59514382	CCM 100 SPEEDO 0-120 KM/H S tb G
A2C60000251	A2C59514388	CCS 52 PRESSOIL 0-5 BAR S tb G
A2C60000259	A2C59514396	CCS 52 PRESSBR1 0-10 BAR S tb G
A2C60000260	A2C59514397	CCS 52 PRESSBR2 0-10 BAR S tb G
A2C60000269	A2C59514406	CCS 52 TEMPTR 50-150C S tb G
A2C60000273	A2C59514410	CCS 52 TEMPWA 40-120C S tb G
A2C60000274	A2C59514411	CCS 52 TEMPWA 40-120C D tb G
A2C60000275	A2C59514412	CCS 52 TEMPWA 100-280F D tb G
A2C60000278	A2C59514415	CCS 52 LEVELFUEL 0-1 S tb G
A2C60000279	A2C59514416	CCS 52 LEVELFUEL E-F S tb G
A2C60000281	A2C59514418	CCS 52 LEVELWW 0-1 S tb G
A2C60000282	A2C59514419	CCS 52 VOLT 8-16V S tb G
A2C60000284	A2C59514421	CCS 52 VOLT 18-32V S tb G
A2C60000297	A2C59514428	CCS 52 PRESSBR1 0-150 PSI D tb G
A2C60000299	A2C59514430	CCS 52 LEVELADBLUE 0-1 S tb G
A2C60000354	A2C59514431	CCS 52 PRESSOIL 0-10BAR S on tb G
A2C60000355	A2C59514432	CCS 52 TEMPWA 40-120 C S on tb G
A2C60000357	A2C59514434	CCS 80 SPEEDO 0-60 KM/H S tb G
A2C60000360	A2C59514437	CCS 100 TACHO 0-3*1000/MIN S tb G
A2C60500641	A2C59514439	CCB BLACK BOX G



1.3.2 Ocean Link

Plug & play - the fastest way to access precision engine data.

Engines on modern sports and leisure boats increasingly feature electronic management. To meet these new requirements, VDO now boasts a modular instrumentation concept for marine application: Ocean Link. The main element and information powerhouse is a multifunctional tachometer with direct access to the CANbus controlling the engine. The instrument

can display and forward all available data to up to 20 additional satellite instruments. Installation follows the practical plug & play principle, making further system expansion particularly convenient, with no need for complicated programming. Ocean Link has already established a successful track record with leading engine manufacturers.

Ocean Link - Explore the data horizon

The central instrument automatically presents all the key data - up to 256 standard measurement values ranging from oil pressure and fuel consumption to operating hours - on a generously proportioned digital display. Besides a CAN interface with SAE J1939 data protocol it features two inputs for analogue sensors. The innovative Easy Link data connection renders complicated cabling unnecessary. The CAN interface also allows a second central instrument to be hooked up for

positioning on the flybridge, for example. Satellite instruments for further dynamic measurement values receive updates from the central instrument every 20 ms. Ocean Link is available in various designs, including a range of installation dimensions and metric and imperial scales. The instruments can also be conveniently integrated into customer-specific panel solutions.

Ocean Link benefits

Straightforward system expansion <ul style="list-style-type: none"> • Easy Link connector • Up to 20 other satellite instruments per central instrument • Minimal cabling 	Plug & play principle <ul style="list-style-type: none"> • Easy installation • No reprogramming 	Customer-specific integration <ul style="list-style-type: none"> • Combined instruments • Panel solutions 	All Ocean Link benefits <ul style="list-style-type: none"> • Double lens system • Flush mounting possibility
---	--	--	---

Engine data



VDO Easy Link instrument bus



Engine oil temperature



Exhaust gas temperature



Transmission oil temperature



Boost pressure



Transmission oil pressure



Engine coolant temperature



Fuel level



Fuel flow rate

Technical data

Specification	Central instrument (85 mm)	Satellite instrument (52 mm)
Housing	Plastic (flame-retardant) according to UL94-V0	Plastic (flame-retardant) according to UL94 - V0
Bezel	Plastic, coloured	Plastic, coloured, clipable
Lens	Plastic, double lens, anti-reflection	Plastic, double lens, anti-reflection
Illumination	Transmitted light, red LED, 8 dimmer steps	Transmitted light, red LED, 8 dimmer steps, adjustable via master
Display	132 x 33 pixel	
Connections	DELPHI connector, GT 150 Series	Super Seal 1.5 Series AMP connector 282105-1
Installation	Housing nut, nut jam high 0-17mm	Mounted from the front, housing nut, nut jam height 0-12 mm, studs 12-25 mm flush mount: for 3 mm panel thickness with mounting angle, screws and studs on panel gasket
Indication area	3,000 or 4,000	270° (depending on slave functionality)
Nominal voltage	12/24 volts	
Nominal position	0-90°	any
Operating temperature	-20 °C to +70 °C (at nominal voltage)	-20°C to +70°C (at nominal voltage)
Storage temperature	-30 °C to +85 °C	-30°C to +85°C
EMC	DIN EN 61000-6-2 & 6-3 according to EMC Directive 2004/108/EEC	CE according to EMC directive
Protection class	IP65, mounted, front side to IEC 529	IP65, mounted, front side
Max. no. Satellites		Max. 20 gauges and 20 m cable length connected to central instrument
Current consumption	120 mA without, 140 mA with illumination	<70 mA with illumination
CANbus	SAE J1939 protocol	Easy Link bus uni-directional from central instrument to satellite
Power supply	10 V - 30 V	

Important data is displayed automatically on the large digital display. As many as 20 different parameters, such as oil pressure, fuel consumption, and operating hours, can be displayed on additional peripheral instruments. In addition to a CAN interface running the SAE J1939 data protocol, the master instrument also features two inputs for analog sensors. The innovative serial data link makes complex cabling a thing of the past. All instruments can be easily integrated into customer-specific instrument panel solutions.

Part Number	Dial color	Range
52 MM SATELLITE - BOOST PRESSURE		
N02-140-508	Black	0 – 3 bar
ENGINE COOLANT TEMPERATURE		
N02-311-056	Black	40 – 120 °C
N02-311-552	Black	100 – 250 °F
N02-311-060	White	40 – 120 °C / 100 – 250 °F
ENGINE OIL PRESSURE		
N02-140-156	Black	0 – 10 bar
N02-140-512	Black	0 – 150 psi
N02-140-160	White	0 – 10 bar / 145 psi
ENGINE OIL TEMPERATURE		
N02-311-054	Black	50 – 150 °C
N02-311-542*	Black	100 – 300 °F
EXHAUST GAS TEMPERATURE		
N02-311-540	Black	100 – 900 °C
N02-311-546	Black	200 – 1,700 °F
FUEL LEVEL		
N02-224-082	White	0 – 4/4
TRANSMISSION OIL PRESSURE		
N02-140-154	Black	0 – 25 bar
N02-140-516*	Black	0 – 360 psi
N02-140-158	White	0 – 25 bar / 0 – 360 psi

Part Number	Dial color	Range
TRANSMISSION OIL TEMPERATURE		
N02-311-536	Black	50 – 150 °C
N02-311-544*	Black	120 – 300 °F
TURBO INLET TEMPERATURE GAUGE A		
N02-311-554	Black	100 – 900 °C
N02-311-548*	Black	200 – 1,700 °F
TURBO INLET TEMPERATURE GAUGE B		
N02-311-556	Black	100 – 900 °C
N02-311-550*	Black	200 – 1,700 °F
VOLTMETER		
N02-413-058	Black	18 – 32 V
N02-413-074	White	8 – 16 V
N02-413-060	White	18 – 32 V
85 MM CENTRAL INSTRUMENT - TACHOMETER		
N02-012-920	Black	0 – 3,000 min-1
N02-012-922	Black	0 – 4,000 min-1
A2C59500012	Black	0 – 5,000 min-1
N02-012-928	White	0 – 3,000 min-1

1.3.3 Accessories

CANCOCKPIT

SOFTWARE



Part Number	Description	Units per pack
X11-602-000-010	CANcockpit Interface (WINGauge CMD Line)	1

WIRING HARNESSES

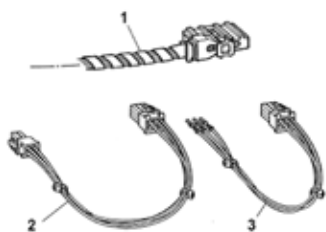

Part Number	Description	Units per pack
A2C53041729	Harness Type A (Central instrument)	10
A2C53344035	CCH Type B Gold (Central-Satellite)	10
A2C53344036	CCH Type C Gold (Satellite-2-Satellite)	100

ACCESSORIES

X10-110-397-006	Demo Case	1
-----------------	-----------	---

OCEAN LINK



Part Number	Description	Units per pack
X11-719-000-037	Connector, complete	1
A2C53092432	Ocean Link Master cable (not included in the instrument packaging)	



1.3.4 Centrobase 350/400

The new CAN-capable multifunctional solution.

Instruments are very important sources of information for drivers. We offer remarkably robust and reliable instrumentation solutions that are tough enough to handle the environmental conditions in which specialty and utility vehicles operate. They always enable the driver to view all key vehicular data at a glance.

A versatile, multifunctional instrument for many applications.

Centrobase 350/400 is a multifunctional instrument featuring an LCD display. It is designed for construction, farming and forestry machinery, stationary equipment and similar applications. Building on the proven design of the Viewline housing, this instrument is developed according to very high standards of quality.

Featuring a modern look, it offers the perfect front-sided IP protection. Its compact design enables the driver/operator to monitor many parameters simultaneously. Several options are available to customize the instrument to the customer's needs.

Centrobase 350

- Robust and flexible design for versatile applications.
- Pointer for vehicle speed or engine speed indication.
- CAN capability e. g. SAE J1939.
- Protection in accordance with IP 67 (front).



Centrobase 350

CAN-capable Multifunction Solution

This multifunctional instrument with segment display is intended for use in construction and agricultural equipment, marine applications and similar. Based on the Viewline housing concept, the cluster provides an ideal IP protection class, a modern appearance and high quality standards. It allows monitoring of many parameters in a compact design and there are several customization opportunities to meet specific customer demand.

Technical data

Dimensions:	Installation diameter: 110 mm External diameter: 126 mm Installation depth: 50 mm (1.97 in) (top mounted, without connector) 59 mm (2.32 in) (flush mounted without connector)
Nominal voltage:	12 VDC
Operating voltage:	8.5 to 16 VDC
Operating temperature:	-20 °C (-4 °F) to +85 °C (+185 °F); -20 °C (-4 °F) to +70 °C (+158 °F), plated bezel (chrome)
Storage temperature:	-40 °C (-40 °F) to +85 °C (+185 °F) -40 °C (-40 °F) to +70 °C (+158 °F), plated bezel (chrome)
Analog indication:	Analog gauge with a max. deflection angle of 230°, e. g. speed indication or engine speed indication
LC-display:	Viewing area: 37 x 11mm 6 x 14 segment indication usable for several functions, e. g. engine hours counter, odometer, trip distance, speed and supply voltage
Warning lamps:	Max. 7 tell-tales, configurable (LED colour and ISO symbol)
Interfaces:	CAN: 1x (CAN 2.0B, e. g. SAE J1939) Analog: up to 12 x Digital: up to 16 x
Internal buzzer:	630 Hz and 1100 Hz / 60 dB at 10 cm distance
Mounting/fixing:	Diameter: 110 mm (housing diameter) Top mount: Clamp ring or Studs and bracket Flush mount: Fixing Bracket
Nominal position:	According to DIN 16257 NL 0 to NL 85
Protection class:	According to DIN 60529 Front: IP 67* Back: IP 40*

*Nominal position

Centrobase 400

- Robust and flexible design for versatile applications.
- CAN capability e. g. SAE J1939.
- Pointer for vehicle speed or engine speed indication.
- Up to 27 tell-tales.
- 3-line LC display.
- Protection in accordance with IP 67 (front).
- Anti-fog double lens.



Centrobase 400

Manufactured to fit every demand!

The instrument can readily be adapted to match specific requirements. Our customizing options go beyond front rings and face layouts. We can also adapt application-driven CAN messages, the values of threshold and warning indicators, illumination colors and display contents to suit the customer's requirements.



Technical data

Dimensions:	Installation diameter: 110 mm External diameter: 126 mm Installation depth: 50 mm (1.97 in) (top mounted, without connector) 59 mm (2.32 in) (flush mounted without connector)
Nominal voltage:	12 VDC
Operating voltage:	8 to 16 VDC
Operating temperature:	-20 °C (-4 °F) to +85 °C (+185 °F); -20 °C (-4 °F) to +70 °C (+158 °F), plated bezel (chrome)
Storage temperature:	-40 °C (-40 °F) to +85 °C (+185 °F) -40 °C (-40 °F) to +70 °C (+158 °F), plated bezel (chrome)
Analog indication:	Analog gauge with a max. deflection angle of 230°, e. g. speed indication or engine speed indication
LC-display:	Viewing area: 46 x 23 mm (1.81 x 0.91 in) 3-line segmented display with: • 6 x 7 segment indication usable for up to four functions, e. g. engine hours counter, odometer, trip distance and battery voltage • 2 x 12 bar graph segments, e. g. coolant temperature and fuel level
Warning lamps:	Up to 27 tell-tales
Interfaces:	CAN: 1x (CAN 2.0B, e. g. SAE J1939) Analog: up to 12 x Digital: up to 16 x
Internal buzzer:	630 Hz and 1100 Hz / 60 dB at 10 cm distance
Mounting/fixing:	Top mount: bezel or bracket and studs Flush mount: clips
Nominal position:	According to DIN 16257 NL 0 to NL 85
Protection class:	According to DIN 60529 Front: IP 67* Back: IP 40*

* Nominal position



1.3.5 FlexCluster

Countless Tasks. One Solution

Our products always meet the highest standards with regard to quality, durability, and aesthetics, but the FlexCluster indicating instrument offers even more: maximum functionality in every respect.

Maximum flexibility: The tried and tested Gateway feature allows data to be processed from two different CAN buses running different protocols (e.g., SAE J1939 and/or CAN Open). This enables flexibility in use and ensures that all important data and information can be transmitted to other control units. Additional peripheral instruments, from oil pressure through fuel consumption to operating hours, can also be controlled via the FlexCluster. Accordingly, all data required for vehicle operation can be displayed.

Maximum safety: The FlexCluster indicating instrument provides a large number of customizable settings. DTC (Diagnostic Trouble Code) handling in accordance with the SAE J1939 protocol is thus made extremely simple. A back-up system ensures that the integral real-time clock is not affected if there is a loss of power.

Maximum compatibility: Maximum compatibility is guaranteed thanks to a wide array of analog and digital frequency inputs in conjunction with multiple CAN inputs.

Maximum individuality: The layout of the central dot-matrix display is fully customizable and can even be programmed to show personalized icons and corporate logos. All warning lights can be individually customized in terms of shape and color. There is also a range of options for the dials and bezels.

Maximum ergonomics: The best possible ergonomics are guaranteed with this space-saving design. It not only enables optimal readability of the instruments but also helps to increase comfort levels in the driver's cab.

Maximum spontaneity: Thanks to a specialized software, the FlexCluster indicating instrument can be programmed and configured to precisely meet any customer requirements. For added convenience, the self-explanatory software allows customers to implement changes themselves as and when required.

Maximum robustness: The extremely high protection rating (IP 67) of the housing means that the FlexCluster is suitable for continuous use under the most extreme conditions of heat/cold, moisture, vibration, etc.

Specifications:	
Dimensions (mm):	290.6 x 143.5 x 72.5
Nominal voltage:	12 V or 24 V
Supply voltage:	9 V to 16 V or 18 V to 32 V
Operating temperature:	-40 °C to + 75 °C
Protection degree:	IP 67 front side and rear side
Features:	
Appearance:	Black dial with red pointers, multicolor printing Customization of dial, telltales, screening rings and HMI possible
Illumination:	white backlight and amber colored display illumination, dimming via PVM
Gauges:	4 gauges (2x large, 2x small) e.g. Speedometer, tachometer, fuel level, coolant temperature or air pressure
Display:	Dot matrix LCD, technology: FSTN Resolution: 115 x 145 Active area: 65.23 x 51.73 mm
Telltales:	24 + 2 (placed near small gauges)
Wake-Up:	CAN or term 15
EOL programming:	KWP2000 on CAN
Analog input (resistive/voltage):	6 (2 can be used as voltage input)
Digital input:	24
Frequency input:	4
Current input:	1
Output:	3 x 500 mA Output can be used as frequency or digital output (Low side switch)
External buzzer output:	1
D+ Generator load:	1 (150 Ω pull up @ 24 V or 53 Ω pull up @ 12 V)
Interfaces:	2 x CAN, 1 x LIN 1 x for additional gauge satellites
Connectors:	2 x Tyco Super Seal (35 pin and 23 pin) In-mold with back cover

This solution offers significant design flexibility in order to realize vehicle functionality and end-customer needs, including enhancing or changing features during the vehicle's lifetime. With a special application programming software, we offer our customers a powerful, established tool for simple programming.

The FlexCluster indicating instrument was specifically developed to withstand the harsh conditions associated with special-purpose vehicles.

With four instrument dials in an ergonomically optimized layout, 26 configurable warning lights, and a large dotmatrix display, the FlexCluster indicating instrument

is one of the most advanced system components available to the special vehicle manufactures today. The extensive customization options allow the system to meet even the toughest requirements, while also providing an optimal combination of individuality and value for money.



1.3.6 Display Controller | MultiViu® Flex 7&4

TFT Display with touch, with/without buttons, OS and application-level programming environment. No application SW and customer HMI but a “very fast route” to get customer specific HMI and application done. Performance: with CAN (NMEA), USB load for application upgrade, Ethernet, Linus OS, camera inputs.



Flex 7 Basic K / Full TK



Flex 7 Basic / Full T



Flex 4 Basic K / Full TK



Flex 4 Basic / Full T

Order Codes

Flex 4 Entry T	A2C59506618
Flex 4 Basic	A2C59506619
Flex 4 Full T	A2C59506620
Flex 4 Entry K	A2C59506621
Flex 4 Basic K	A2C59506622
Flex 4 Full TK	A2C59506623
Flex 7 Basic	A2C59506624
Flex 7 Full T	A2C59506625
Flex 7 Basic K	A2C59506626
Flex 7 Full TK	A2C59506627
In-Dash mounting frame for Multiviu Flex 4 without keys	A2C59506628
In-Dash mounting frame Multiviu Flex 4 with keys and knob	A2C59506629
In-Dash mounting frame Multiviu Flex 7 without keys	A2C59506630
In-Dash mounting frame Multiviu Flex 7 with keys and knob	A2C59506631
Adaptor for RAM® mounting system Multiviu Flex 4	A2C59506632
Adaptor for RAM® mounting system Multiviu Flex 7	A2C59506633
26 pins Tyco Connector	A2C59506634
1 Power cable Multiviu Flex 4 and 7 1,5m	A2C59506635
1 App Buidler Licence	A2C59506637

Variant	Flex 4						Flex 7			
	Basic	Entry T	Full T	Basic K	Entry K	Full TK	Basic	Full T	Basic K	Full TK
Resistive Touch screen	-		x	-		x	-	x	-	x
Keys and Rotary	-		-	x		x	-	-	x	x
CAN	2		2	2		2	2	2	2	2
RS232	1		1	1		1	1	1	1	1
Ana./Dig. Inputs	4		4	4		4	4	4	4	4
Digital Outputs	3		3	3		3	3	3	3	3
Ethernet			1			1	1	1	1	1
Video Input	-	-	1		-	1	1	3	1	3
USB full speed 2.0	1 on rear connector					2 on Front and Rear connector	1 on rear connector			2 on Front and Rear connector
Internal Buzzer	x		x	x		x	x	x	x	x
Light sensor	x		x	x		x	-	-	x	x
RAM	128MB		256MB	128MB		256MB	128MB	256MB	128MB	256MB
Flash Memory	512MB		1GB	512MB		1GB	512MB	1GB	512MB	1GB

Technical Data MultiView Flex 4

Housing:	Plastic with rubber frame
Dimension:	142 x 98 x 43 mm
Installation depth:	36mm, without harness
Display:	4,3" (Viewing area: 95 x 53 mm) TFT color display Aspect ratio 16:9 Resolution 480 x 272 pixels
Operating:	See variant List
Luminance (avg.)	Typ 400 cd/m ²
Contrast ratio:	Typ. 400:1 @20°C
In/Outputs	2 x CAN 2.0B (e.g. SAEJ1939) 1 x RS232 1 X USB 2.0 host /full speed) 4 x configurable analog/digital inputs 3 x digital inputs
CAN Baud Rate:	250 kbit/s; 500 kbit/s; 750 kbit/s; 1000 kbit/s
Internal buzzer:	60 dB(A) at 30 cm distance
Operating Voltage:	9 - 36 VDC
Current Consumption:	Operating: <430mA @ 13,5 VDC Low power < 160mA@13,5 VDC Sleep mode<90mA@13,5VDC
Internal Memory:	see variant List
Real Time Clock (RTC)	Yes, gold cap buffered
Operating System:	Linux
Programming capabilities:	PC configuration tool
Operating Temperature	-30°C to +65°C
storage Temperature:	-40°C to +80°C
Protection Class:	IP 6K5 and IP 6K7 according ISO 20653
Approval	CE ECE-R10 (e-mark)

Variants MultiView Flex 4	Basic	Full T	Basic K	Full TK
Internal memory	Flash: 512 Mbyte RAM: 128 Mbyte	Flash: 1 Gbyte RAM: 256 Mbyte	Flash: 512 Mbyte RAM: 128 Mbyte	Flash: 1 Gbyte RAM: 256 Mbyte
Video Input		1 x analog video		1 x analog video
Ethernet		1 x 10/100 Mbit/s		1 x 10/100 Mbit/s
Touch screen		yes		yes
Keyboard			8 x Softkeys 3 x Hardkeys Rotating encoder	3 1 x 8 x Softkeys 3 x Hardkeys 1 x Rotating encoder

Technical Data MultiView Flex 4

Housing:	Plastic with rubber frame
Dimension:	223 x 139 x 64 mm
Installation depth:	41 mm, without harness
Display:	7" (Viewing area: 192 x 91 mm) TFT color display Aspect ratio 16:9 Resolution 480 x 272 pixels
Operating:	See variant List
Luminance (avg.)	Typ 400 cd/m2
Contrast ratio:	Typ. 400:1 @20°C
In/Outputs	2 x CAN 2.0B (e.g. SAEJ1939) 1 x RS232 1 X USB 2.0 host /full speed) 4 x configurable analog/digital inputs 3 x digital inputs
CAN Baud Rate:	250 kbit/s; 500 kbit/s; 750 kbit/s; 1000 kbit/s
Internal buzzer:	60 dB(A) at 30 cm distance
Operating Voltage:	9 - 36 VDC
Current Consumption:	Operating: <900mA @ 13,5 VDC Low power < 200mA@13,5 VDC Sleep mode<100mA@13,5VDC
Internal Memory:	see variant List
Real Time Clock (RTC)	Yes, gold cap buffered
Operating System:	Linux
Programming capabilities:	PC configuration tool
Operating Temperature	-30°C to +65°C
storage Temperature:	-40°C to +80°C
Protection Class:	IP 6K5 and IP 6K7 according ISO 20653
Approval	CE ECE-R10 (e-mark)

Variants MultiView Flex 7	Basic	Full T	Basic K	Full TK
Internal memory	Flash: 512 Mbyte RAM: 128 Mbyte	Flash: 1 Gbyte RAM: 256 Mbyte	Flash: 512 Mbyte RAM: 128 Mbyte	Flash: 1 Gbyte RAM: 256 Mbyte
Video Input		3 x analog video	1 x analog video	3 x analog video
Ethernet		1 x 10/100 Mbit/s		1 x 10/100 Mbit/s
Touch screen		yes		yes
Keyboard			12 x Softkeys 3 x Hardkeys 1 x Rotating encoder	12 x Softkeys 3 x Hardkeys 1 x Rotating encoder



2. Sensor and Switches

2.1 Speed and RPM Sensors

2.1.1 Blocking Oscillator Sensor

2.1.2 Inductive Sensor

2.1.3 Hall-Effect Sensor

2.1.4 Generator Sensor

2.1.5 Active Wheel Speed Sensor

2.1.1 Blocking Oscillator Sensor

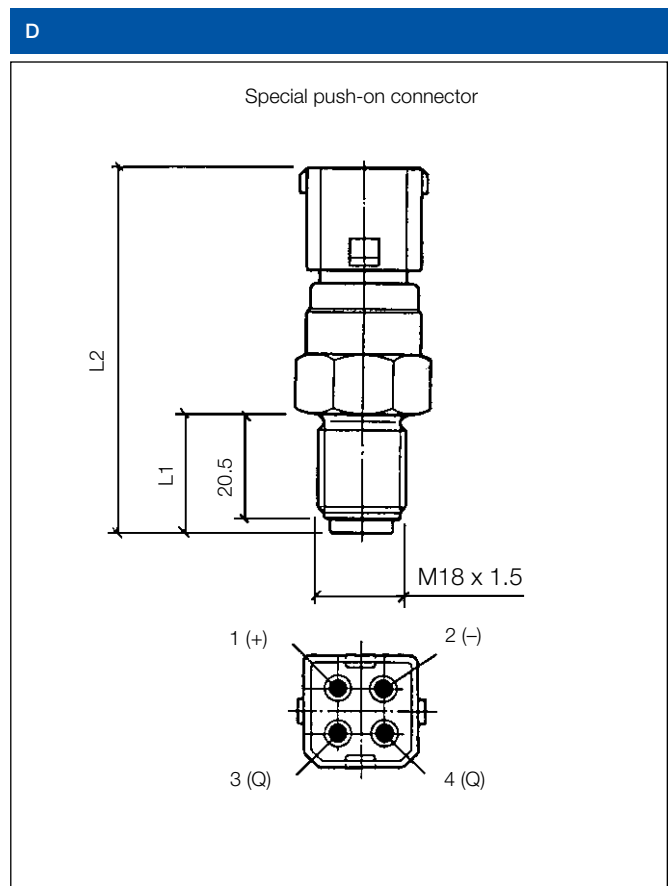
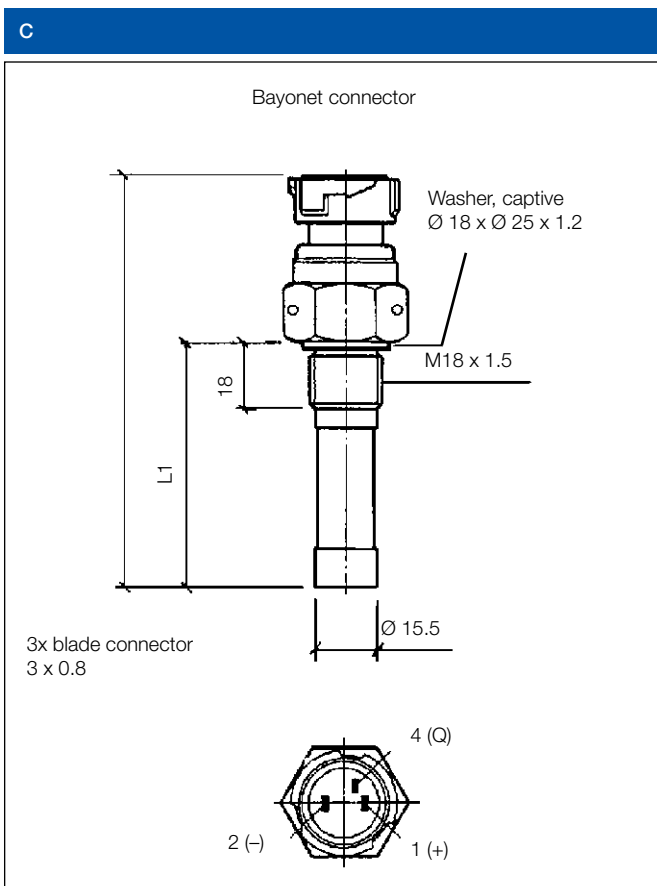
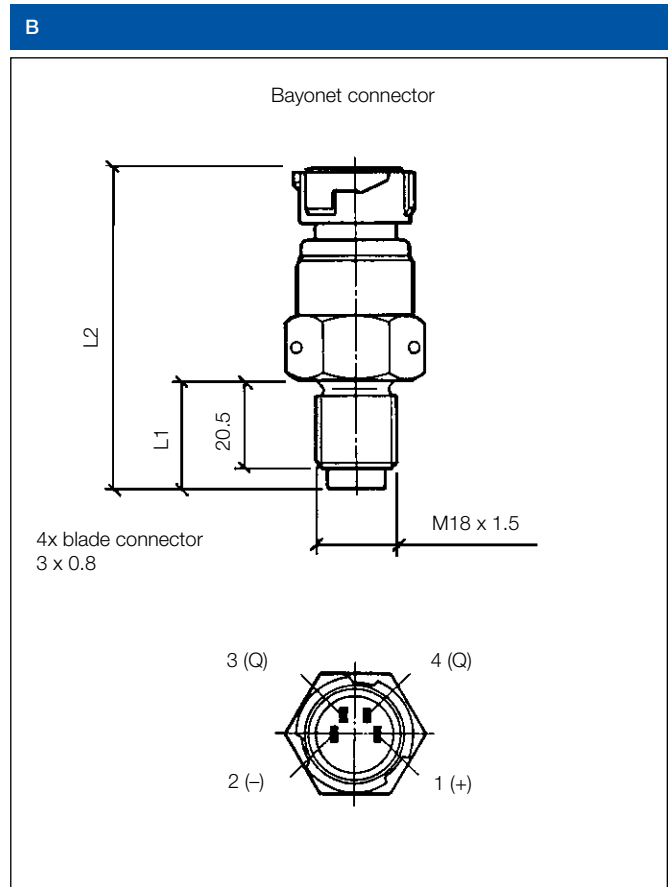
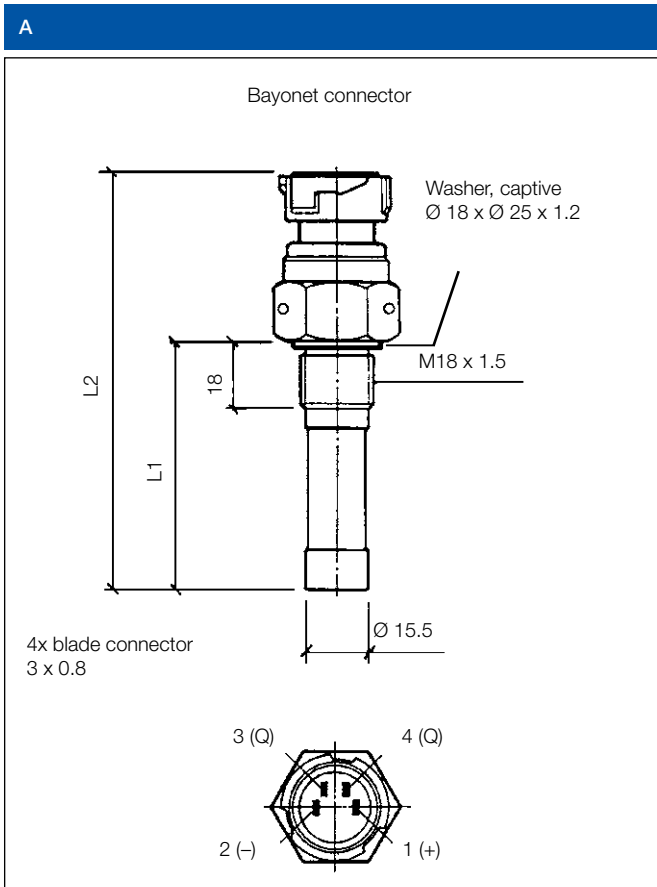

Part Number	Design	Length [mm]	
		L1	L2
340-216-010-003C	D	25	78.3
340-216-005-002C	A	63.2	106
A2C59513983	B	25	74
340-216-005-001C	A	90.2	133

Technical data	
Electrical connection	4-pole, insulated return
SENSOR POWER SUPPLY	
Voltage	8–15 V
Current	12 mA
Operating temperature	-40 °C to +130 °C
Tooth repetition frequency	400 Hz
Distance sensor – pulse wheel	0.3 mm to 1.4 mm

Part Number	Design	Length [mm]	
		L1	L2
340-216-010-004C	C	90.2	133

Technical data	
Electrical connection	4-pole, insulated return
SENSOR POWER SUPPLY	
Voltage	30 V
Current	14 mA
Operating temperature	-40 °C to +130 °C
Tooth repetition frequency	400 Hz
Distance sensor – pulse wheel	0.3 mm to 1.4 mm

2.1.2 Inductive Sensor

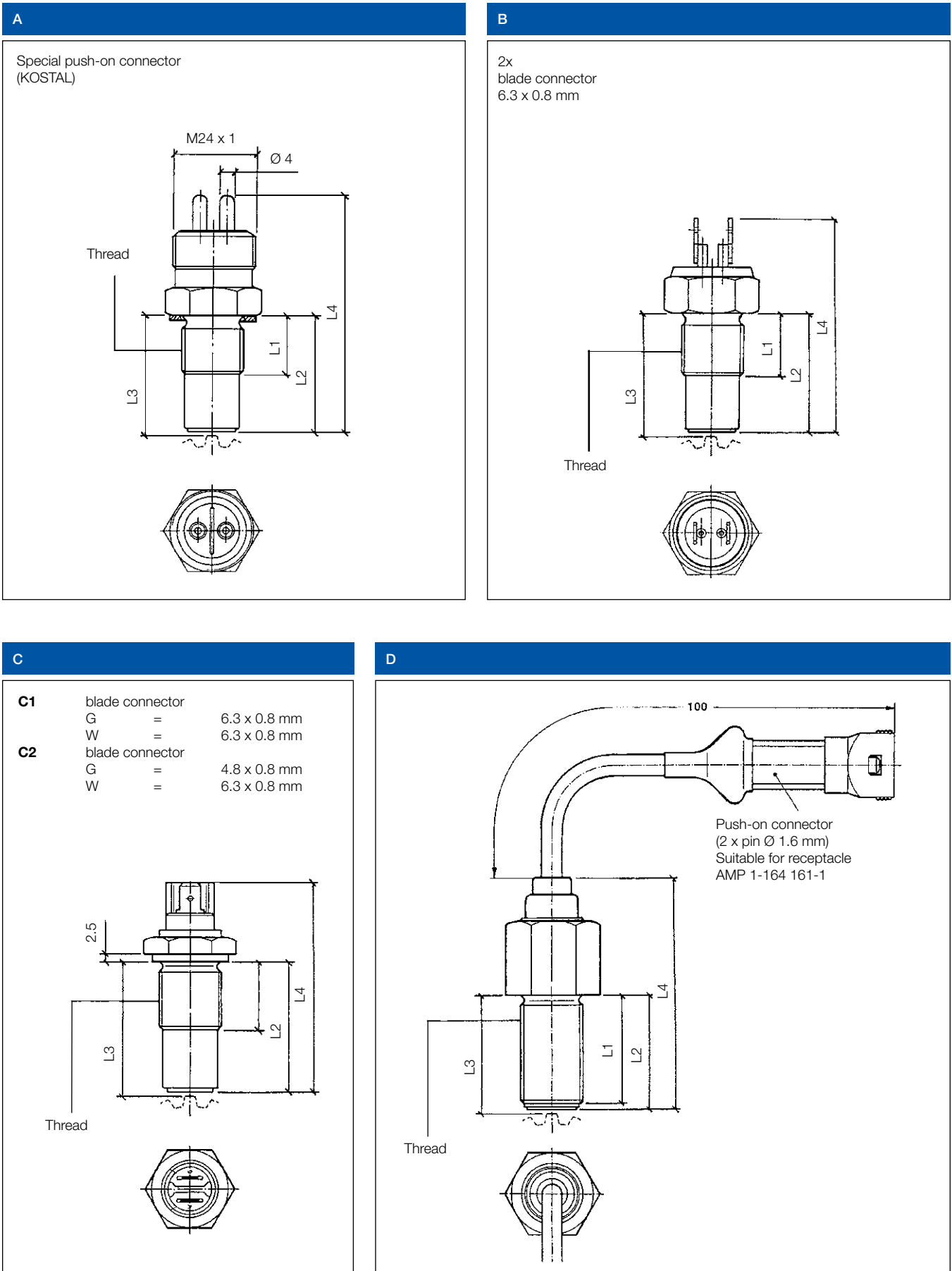

Part Number	Thread	Length [mm]				Design	min. [°C]	RI [Ω]
		L1	L2	L3	L4			
340-804-005-007C	M18 x 1.5	15	35	36.1 ±0.1	71.5	A	-25	1,050
340-804-005-001C	M18 x 1.5	18	35	36.15–35.80	71.5	A	-30	1,050
340-804-005-013A	M18 x 1.5 ¹	18	71.4	72.63–72.20	107.9	A	-30	1,050
340-804-005-015C	M18 x 1.5	18	99.1	101.15–100.55	135.6	A	-30	1,050
340-804-005-018C	M18 x 1.5 ¹	18	45.7	46.95–46.45	82.2	A	-30	1,050
340-804-005-020C*	M18 x 1.5 ¹	18	37.3	38.45–38.1	73.8	A	-30	1,050
340-804-006-002C	M18 x 1.5	18	35	36.1 ±0.1	63.5	B	-30	1,050
340-804-007-019C	M18 x 1.5 ^{8,9}	18.2	70.7	71.8 ±0.1	79.7	C2	-25	1,050
340-804-030-006B	M18 x 1.5	18.2	70.7	71.8 ±0.1	93.5	D	-25	1,050
340-804-007-020C	M18 x 1.5 ^{8,9}	20	39	40.1 ±0.1	62	C2	-25	1,050
340-804-030-005B	M18 x 1.5	23.3	25	26.1 ±0.1	67	D	-25	1,050
340-804-005-002C	M18 x 1.5	24.9	26.5	27.65–27.30	63	A	-30	1,050
340-804-005-028C	M18 x 1.5	24.9	63.4	64.55–64.20	99.9	A	-30	1,050
340-804-005-033C	M18 x 1.5	24.9	26.5	27.5	63	A	-30	1,050
340-804-007-002A	M18 x 1.5	27.5	28.5	29.6 ±0.1	70	C1	-25	1,050
340-804-007-004C	3/4" - 16 UNF-2A ⁸	27.5	28.5	29.6 ±0.1 ^{+0.15} -0.2	70	C1	-25	1,050
340-804-007-013C	M18 x 1.5 ⁸	27.5	28.5	29.6 ±0.1	70	C1	-25	1,050
340-804-006-007C	M18 x 1.5	33	34	35.1 ±0.1	62	B	-30	1,050
340-804-007-001C	M18 x 1.5 ⁹	33	34	35.1 ±0.1	70	C1	-25	1,050
340-804-007-003C	M18 x 1.5	33	34	35.1 ±0.1	64.5	B	-25	1,050
340-804-007-011C/G	M18 x 1.5	33	34	35.1 ±0.1	70	C1	-25	1,050

1 With sealing washer, captive

8 With collar

9 With hexagonal nut M18 x 1.5

*Supplied on request – limited availability

Technical data	
Electrical connection	2-pole, insulated return
VOLTAGE INDEPENDENT	
Operating temperature	-25 °C to +140 °C
Internal resistance, Ri	1,050 Ω ± 100 Ω
TEST CONDITIONS	
Gear	36 teeth
Diametral pitch	2.75
Rotational speed	416.6 min ⁻¹
Frequency	250 Hz
Tooth width	7.5 mm
Load	47 kΩ
GEAR CENTERED	

2.1.3 Hall-Effect Sensor

Dimensions [mm]

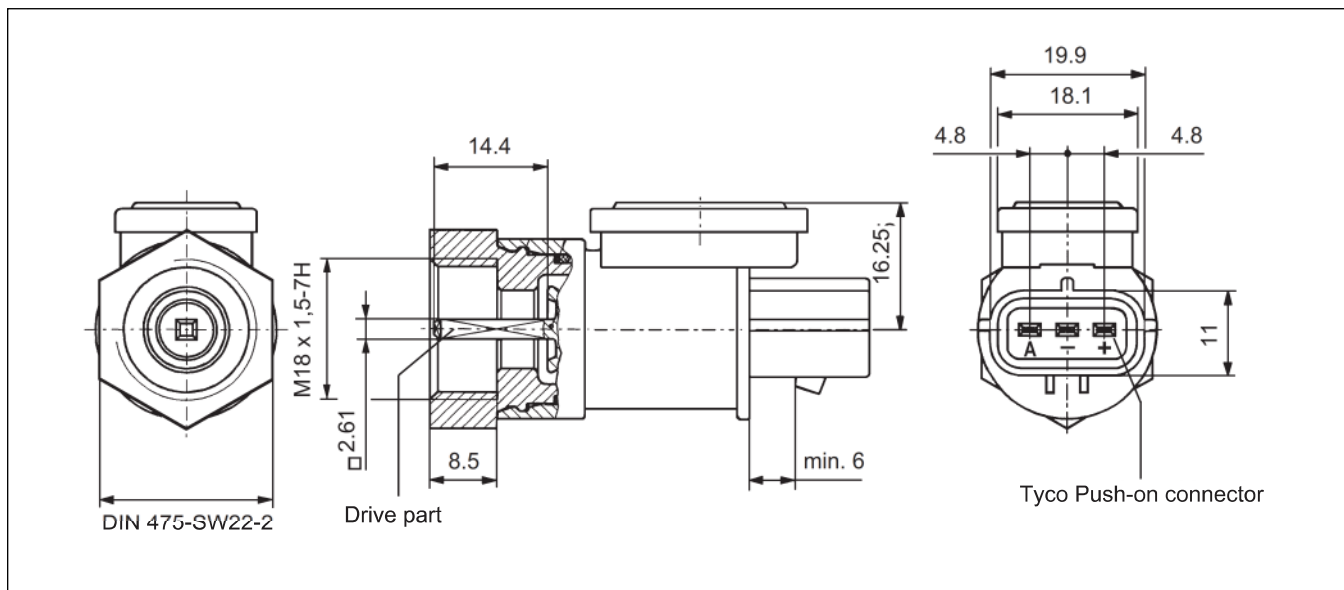

Technical data

Electrical connection	3-pole, insulated return
Voltage independent	10.8V to 16V
Operating temperature	-30°C to +150°C
Storage temperature	-40°C bis +150°C
Rotational speed	4500 min ⁻¹ max
Number of pulses per revolution	4

Part number: 340-214-013-001Z

2.1.4 Generator Sensor

Dimensions [mm]

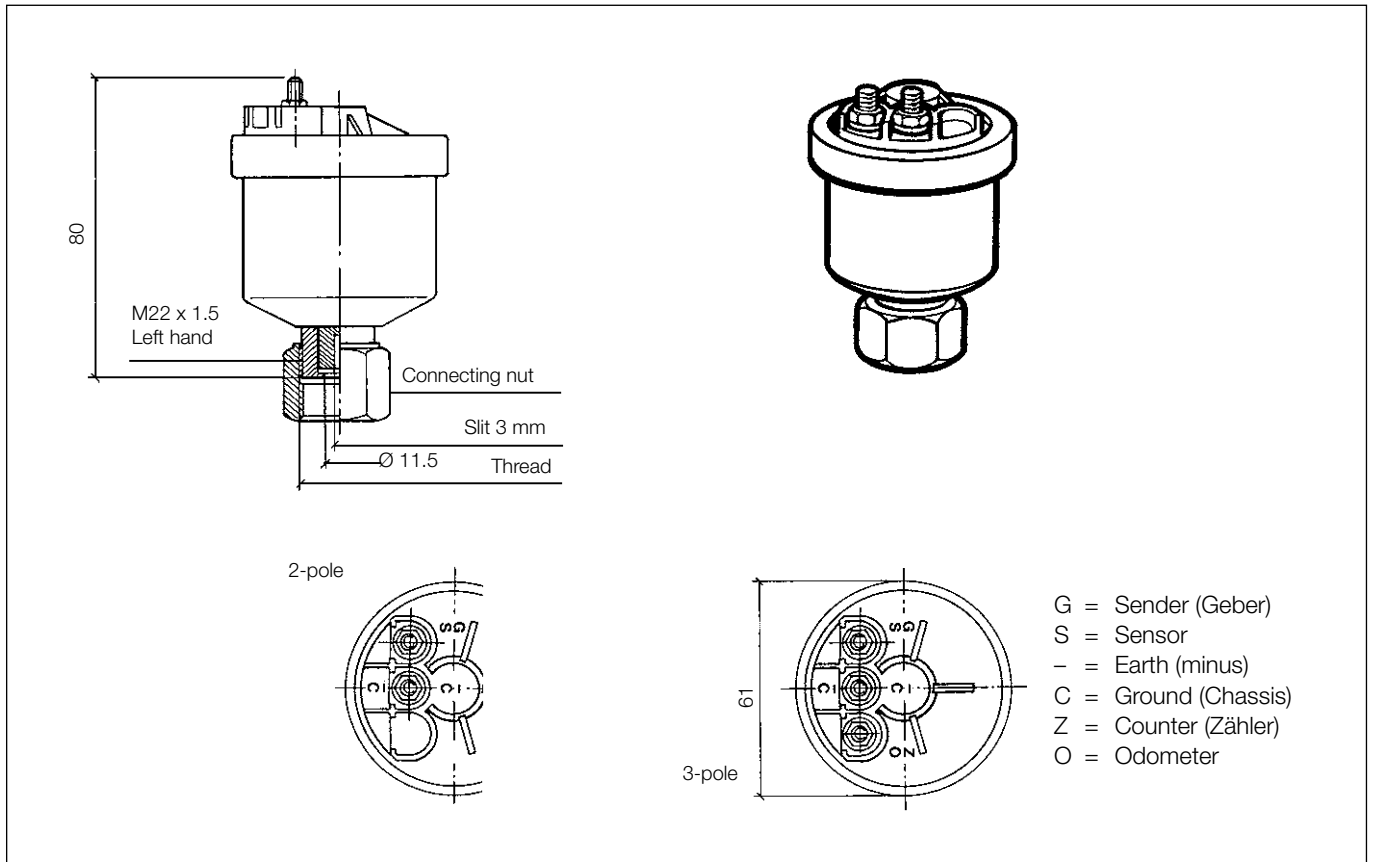

Type of connection

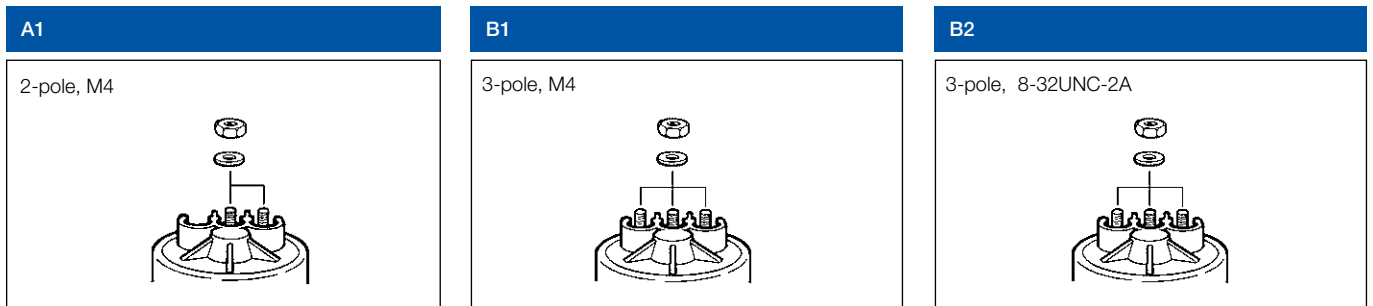

Part Number	Thread	Type of connection
340-808-001-002C	M22 x 1.5	A1
340-807-001-001C	M22 x 1.5	B1
340-808-001-004G	7/8" - 18NS-2A	A1
340-807-001-003C	7/8" - 18UNS-2B	B2

Technical data	
Electrical connection	2-pole, 3-pole, insulated return
Rotational speed	Max. 3,000 min ⁻¹
No-load voltage	19.3 V at 2,000 min ⁻¹
Operating temperature	-25 °C to +90 °C
Protection rating	IP54 as per DIN 40050

2.1.5 Active Wheel Speed Sensor

Dimensions [mm]

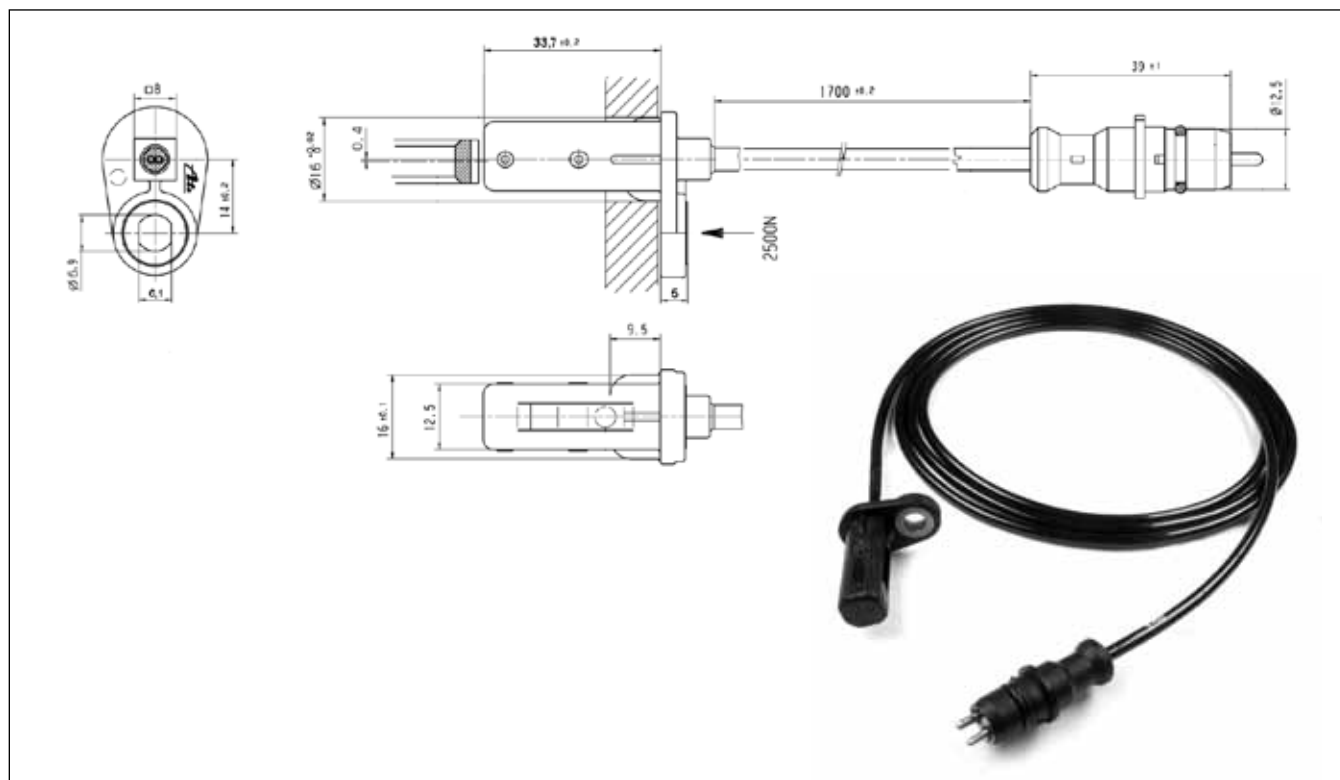

Part Number: 10.0711-6146.3

Technical data

Voltage	-40 °C to +60 °C: 7,5 V–20 V +60 °C to +150 °C: 7,5 V–16 V
Operating temperature	Sensor body: -40 °C to +150 °C Cable/Plug: -40 °C to +115 °C
Plug Swoboda	IP 67 according to DIN 40050 part 9
Current	I_{low} : 7 mA (+20%/-16%) I_{high} : 14 mA (+20%/-16%)
Cable length	1.700 mm (Other lengths available on request)

Description

This active sensor, derived from the large series production, features high reliability and robustness. Due to its large air tolerance it can be fitted to the vehicle with little effort.

- Pulse generator in form of a pole wheel.
- Suitable cable harness interface in form of a so-called “Swoboda” plug.
- Fastened as shown.



2.2 Pressure Sensors

- 2.2.1 Pressure Sensor, Single-Pole,
Common Ground
- 2.2.2 Pressure Sensor with Warning
Contact,
Common Ground
- 2.2.3 Pressure Sensor, Insulated Return
- 2.2.4 Pressure Sensor with Warning
Contact,
3 Connections

2.2.1 Pressure Sensor, Single-Pole, Common Ground

Circuit diagram

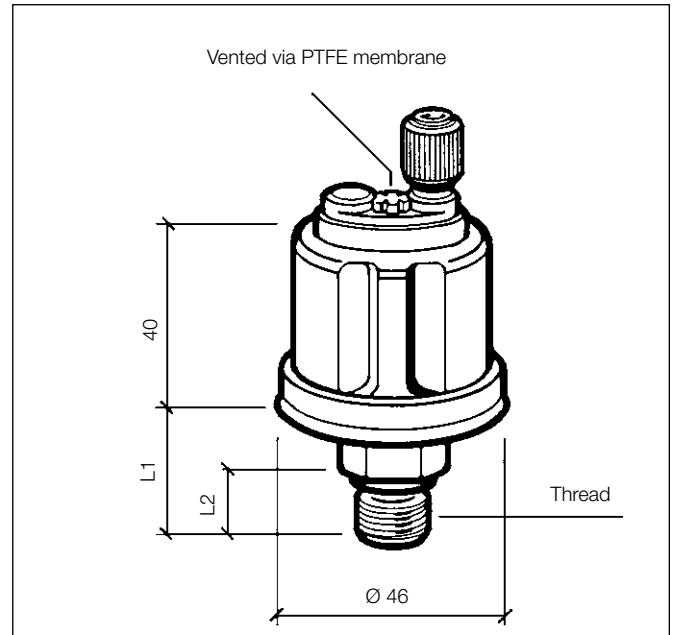
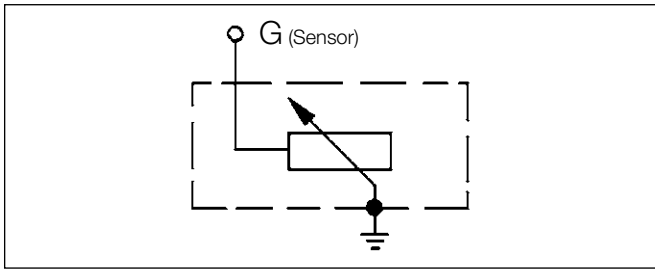

Type of connection

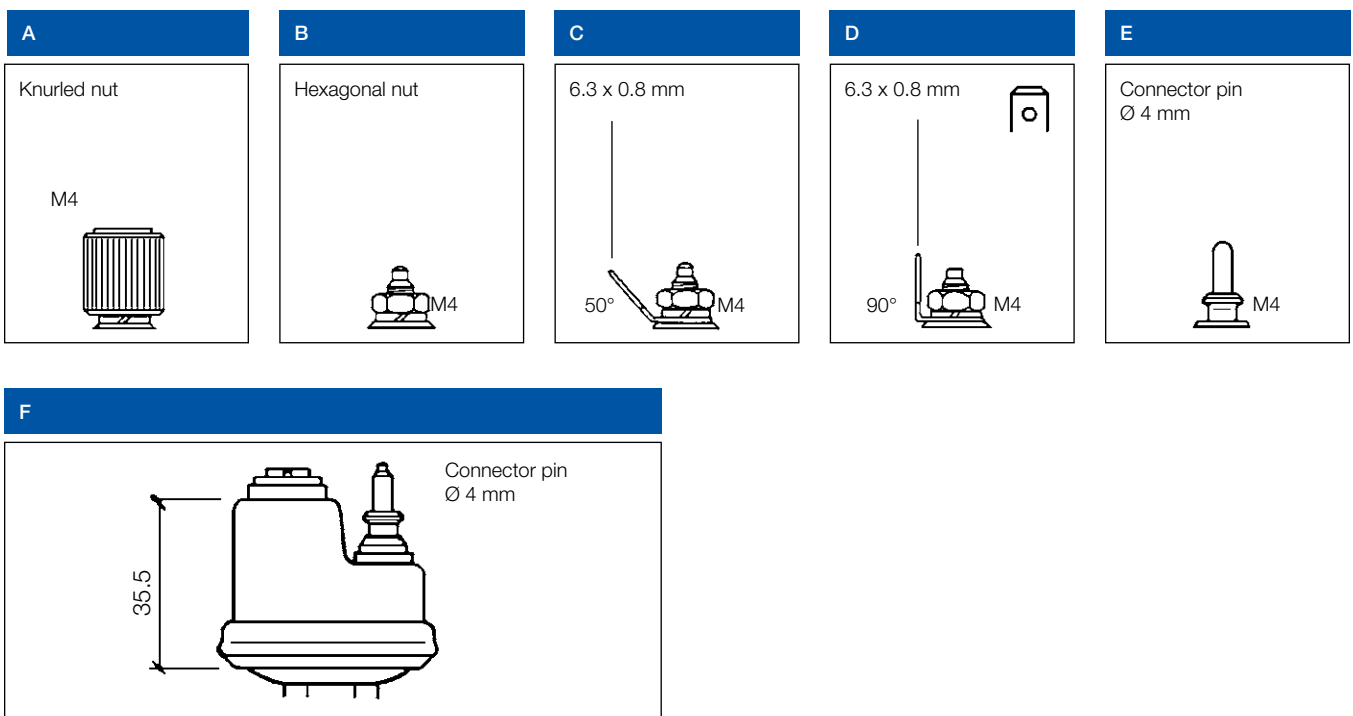

Part Number	Measuring range	Thread	Dimension		Type	bar
	[bar]		L1 [mm]	L2 [mm]		[max. 2 sec.]
360-081-029-087C	3	M12 x 1.5	20.5	12	E	30
360-081-052-003C	3	M12 x 1.5	20.5	12	F	30
360-081-029-001C	5	M10 x 1 tapered, short	19.5	11	A	30
360-081-029-004C	5	1/8" - 27 NPTF	19.5	11	A	30
360-081-029-008C	5	1/4" - 18 NPTF	23.8	15.3	A	30
360-081-029-025C	5	M18 x 1.51	20.5	12	A	30
360-081-029-026C	5	M14 x 1.5	20.5	12	A	30
360-081-029-041C	5	1/8" - 27 NPTF	19.5	11	D	30
360-081-029-059C	5	M18 x 1.51	20.5	12	B	30
360-081-029-065C	5	M14 x 1.5	25.5	12	B	30
360-081-029-085C	5	M12 x 1.5	20.5	12	A	30
360-081-029-099C**	5	M12 x 1.25	19.5	10	A	30
360-081-029-010C	10	M10 x 1 tapered, short	19.5	11	A	30
360-081-029-012C	10	1/8" - 27 NPTF	19.5	11	A	30
360-081-029-013C	10	M12 x 1.5	20.5	12	A	30
360-081-029-020C	10	1/4" - 18 NPTF	23.8	15.3	A	30
360-081-029-033C	10	M14 x 1.5	20.5	12	A	30
360-081-029-038C	10	M14 x 1.5	20.5	12	C	30
360-081-029-042C	10	1/8" - 27 NPTF	19.5	11	C	30
360-081-029-062C	10	R 1/8 DIN 2999	19.5	11	C	30
360-081-037-006C	16	M14 x 1.5	20.5	12	B2	40
360-081-037-007C	16	1/8" - 27 NPTF3	20.5	12	D	40
360-081-037-019C	16	M12 x 1.5	20.5	12	B	40
360-081-037-003C	25	M18 x 1.5	20.8	12	D	50
360-081-037-008C	25	M10 x 1 tapered, short	19.5	11	C	50
360-081-037-010C	25	1/8" - 27 NPTF	19.5	11	D	50
360-081-037-011C	25	M10 x 1 tapered, short3	19.5	11	C	50
360-081-037-013C	25	M14 x 1.5	20.5	12	D	50
360-081-037-017C	25	M14 x 1.5	20.5	12	D	50
360-081-037-018C	25	M18 x 1.5	20.5	12	D	50

**Supplied on request – limited availability

Technical data

Rated voltage	6–24 V
Operating temperature	-25 °C to +100 °C
Resistor range	10 Ω to 184 Ω

2.2.2 Pressure Sensor with Warning Contact, Common Ground

Circuit diagram

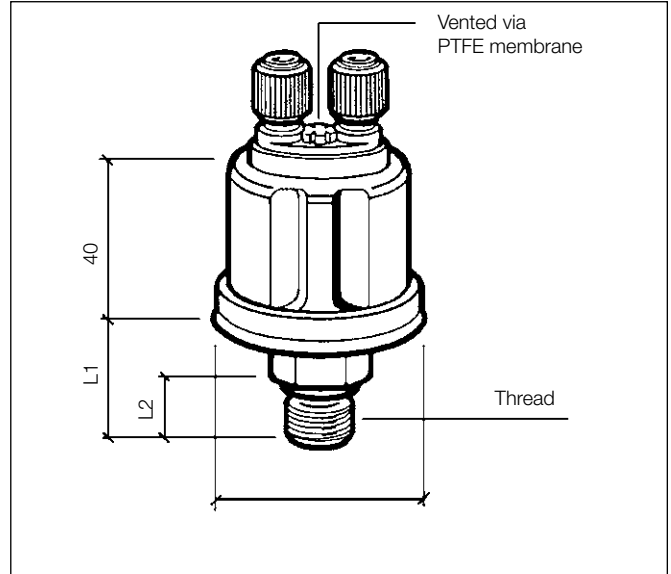
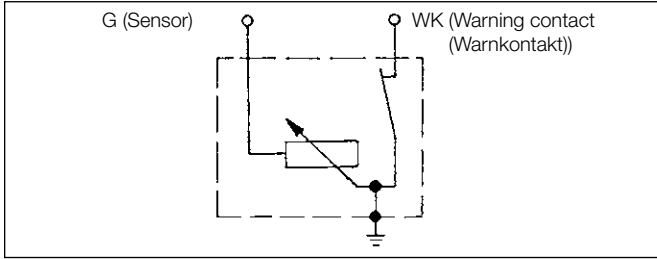

Type of connection

<p>A</p> <p>(2x) Knurled nut, M4</p> <p>M4</p>	<p>B</p> <p>(2x) 6.3 x 0.8 mm (50°)</p> <p>M4</p>	<p>C</p> <p>WK 6.3 x 0.8 mm (50°) G 4.8 x 0.8 mm (50°)</p> <p>M4</p>	<p>D</p> <p>WK 4.8 x 0.8 mm (50°) G 6.3 x 0.8 mm (50°)</p> <p>M4</p>
<p>E</p> <p>(2x) Hexagonal nut, M4</p> <p>M4</p>	<p>F</p> <p>WK 6.3 x 0.8 mm (90°) G M4</p> <p>M4</p>	<p>G</p> <p>G 6.3 x 0.8 mm (50°)</p> <p>M4</p>	<p>H</p> <p>(2x) 6.3 x 0.8 mm</p> <p>M4</p>
<p>J</p> <p>WK 4.8 x 0.8 mm (90°) G 6.3 x 0.8 mm (90°)</p> <p>M4</p>	<p>K</p> <p>WK 6.3 x 0.8 mm (90°) G 4.8 x 0.8 mm (90°)</p> <p>M4</p>	<p>L</p> <p>Hexagonal nut, M5</p> <p>M5</p>	

Type of connection

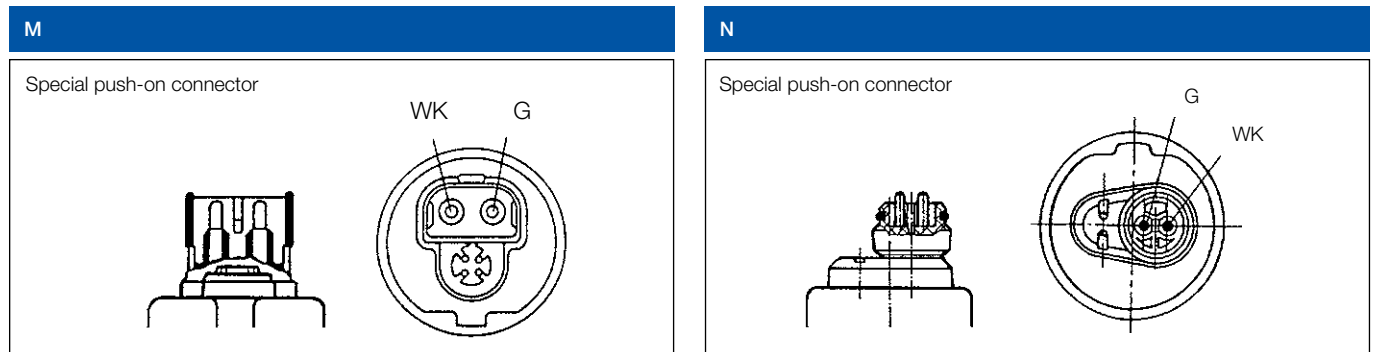

Part Number	Measuring range	Thread	Warning contact	Dimension		Type	bar
	[bar]		[bar]	L1 [mm]	L2 [mm]		[max. 2 sec.]
360-081-030-001C	5	M10 x 1 tapered, short	0.25 ±0.15	19.5	11	A	30
360-081-030-002C	5	M10 x 1 tapered, short	0.5 ±0.15	19.5	11	A	30
360-081-030-004C	5	M10 x 1 tapered, short	0.7 ±0.15	19.5	11	A	30
360-081-030-008C	5	M12 x 1.5	0.5 ±0.15	20.5	12	A	30
360-081-030-010C	5	1/8" - 27 NPTF	1.4 ±0.3	19.5	11	A	30
360-081-030-014C	5	M10 x 1 tapered, short	0.6 ±0.15	19.5	11	A	30
360-081-030-018C	5	M10 x 1 tapered, short	1.2 ±0.15	19.5	11	A	30
360-081-030-025C	5	M18 x 1.51	0.4 ±0.2	20.5	12	B	30
360-081-030-028C	5	M14 x 1.5	0.5 ±0.15	20.5	12	A	30
360-081-030-033C	5	M14 x 1.51	0.4 ±0.1	20.5	12	F	30
360-081-030-036C	5	M18 x 1.51	0.5 ±0.15	20.5	12	A	30
360-081-030-049C	5	1/8" - 27 NPTF	0.4 ±0.1	19.5	11	A	30
360-081-030-053C	5	M18 x 1.54	0.25 ±0.15	20.5	12	B	30
360-081-030-065K	5	R 1/8 DIN 2999	0.4 ±0.15	19.5	11	B	30
360-081-030-071C	5	M14 x 1.5 ¹	0.4 ±0.15	20.5	12	F	30
360-081-030-085C	5	M18 x 1.5 ¹	0.4 ^{+0.2}	20.5	12	C	30
360-081-030-086C	5	1/8" - 27 NPTF	0.5 ^{+0.2} -0.1	19.5	11	C	30
360-081-030-097C	5	M14 x 1.5	0.5 ±0.15	20.5	12	B	30
360-081-030-119C	5	1/8" - 27 NPTF	1.4 ±0.3	19.5	11	H	30
360-081-030-157C	5	M18 x 1.51	0.5 ^{+0.15}	20.5	12	F	30
360-081-034-002C	5	M14 x 1.5	0.25 ±0.15	20.5	12	L	30
360-081-034-004C	5	M18 x 1.5	0.25 ±0.15	20.5	12	L	30
360-081-062-002A	5	M14 x 1.51	0.4 ^{+0.2}	20.5	12	N	30
360-081-062-004A	5	M14 x 1.51	1.0 ^{+0.2}	20.5	12	N	30
360-081-030-154C*	7	1/8" - 27 NPTF	0.7 ±0.15	19.5	10	L	30
360-081-030-009C	10	M10 x 1 tapered, short	0.5 ±0.15	19.5	11	A	30
360-081-030-015C	10	1/8" - 27 NPTF	0.8 ±0.3	19.5	12	A	30
360-081-030-017C	10	M10 x 1 tapered, short	0.9 ±0.15	19.5	11	A	30
360-081-030-019C	10	M12 x 1.5	1.5 ±0.15	20.5	12	A	30
360-081-030-022C	10	M12 x 1.5	0.5 ±0.15	20.5	12	A	30
360-081-030-030C	10	M14 x 1.5	0.7 ±0.15	20.5	12	A	30
360-081-030-031C	10	M10 x 1 tapered, short	0.5 ±0.15	19.5	11	B	30
360-081-030-032C	10	M14 x 1.5	0.5 ±0.15	20.5	12	A	30
360-081-030-037C	10	M18 x 1.51	0.75 ±0.15	20.5	12	A	30
360-081-030-039C	10	M10 x 1 tapered, short	0.75 ±0.15	19.5	11	B	30

Part Number	Measuring range	Thread	Warning contact		Dimension		Type	bar
	[bar]		[bar]	[bar]	L1 [mm]	L2 [mm]		[max. 2 sec.]
360-081-030-041C	10	M10 x 1 tapered, short	2.0 ±0.3		19.5	11	A	30
360-081-030-052C	10	1/8" - 27 NPTF	0.5		19.5	11	A	30
360-081-030-063C	10	M14 x 1.5	1.0 ±0.15		20.5	12	B	30
360-081-030-070C	10	M18 x 1.5 ¹	0.5 ±0.15		20.5	12	B	30
360-081-030-074C	10	M18 x 1.5 ¹	0.5 ±0.15		20.5	12	A	30
360-081-030-075C	10	M14 x 1.5	5.0 ±0.3		20.5	12	H	30
360-081-030-078C	10	M14 x 1.5	1.0 ±0.15 ^{+0.5}		20.5	12	E ²	30
360-081-030-100C	10	1/8" - 27 NPTF	4.0		19.5	11	B	30
360-081-030-107C	10	M16 x 1.5	5.5 ±0.3		20.5	12	D	30
360-081-030-112C	10	M10 x 1 ¹	1.35 ±0.15		18.5	10	K	30
360-081-030-122C	10	M18 x 1.5 ¹	0.75 ±0.15 ^{+0.3}		20.5	12	D	30
360-081-030-138C	10	1/8" - 27 NPTF	1.25		19.5	11	J	30
360-081-030-152C	10	M10 x 1 tapered, short	5.2 ±0.5		19.5	11	H	30
360-081-061-002C	10	M14 x 1.5	0.7 ±0.15		20.5	12	M	30
360-081-061-003C	10	M14 x 1.5	1.0 ±0.15		20.5	12	M	30
360-081-061-006C	10	M12 x 1.5 tapered, short	5.0 ±0.3		21.5	13	M	30
360-081-062-003C	10	M14 x 1.5 ¹	5.5 ±0.3		20.5	12	N	30
360-081-062-005A	10	M14 x 1.5	3.0 ±0.3		20.5	12	N	30
360-081-053-001C	25	1/8" - 27 NPTF ³	15.5 ^{+1.5} _{-0.5}		19.5	11	J	50
360-081-053-003C	25	M18 x 1.5	5.5 ^{+1.0} _{-0.5}		20.5	12	E	50
360-081-053-004C	25	1/8" - 27 NPTF ³	14.5 ^{+1.5} _{-0.5}		19.5	11	B	50

¹ With sealing washer, captive

² Without M4 hexagonal nut

³ With restrictor

⁴ With attachment plate

*Supplied on request – limited availability

Part Number	Measuring range	Thread	Warning contact		Dimension		Type	bar
	[PSI]		[PSI]	[PSI]	L1 [mm]	L2 [mm]		[max. 2 sec.]
360-081-030-020C	80	1/4" - 18 NPTF	8 ±2		23.8	15.3	A	30
360-081-030-023C	80	1/8" - 27 NPTF	6 ±2		19.5	11	A	30

Technical data

Rated voltage	6–24 V
Warning contact	Closes with falling pressure
Switching capacity of warning contact	Max. 5 W non-inductive
Operating temperature	-25 °C to +100 °C
Resistor range	10 Ω to 184 Ω

2.2.3 Pressure Sensor, Insulated Return

Circuit diagram

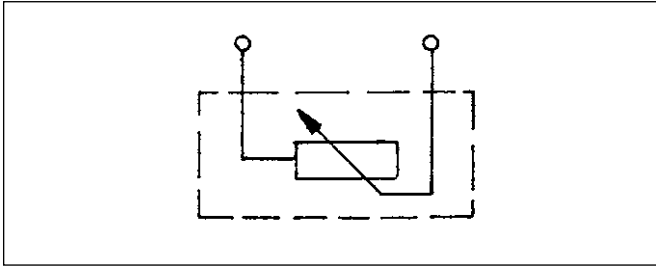

Type of connection

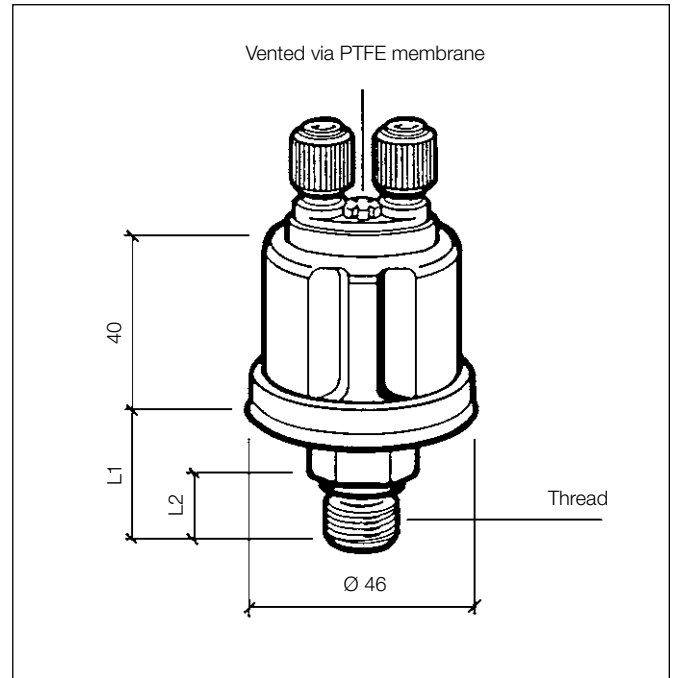
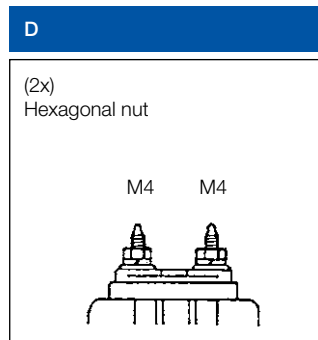
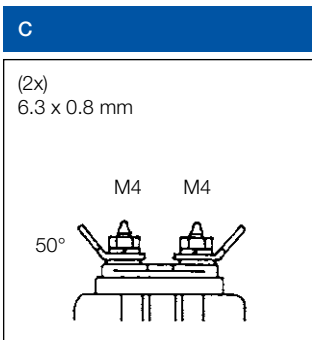
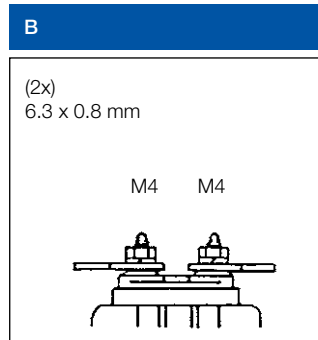
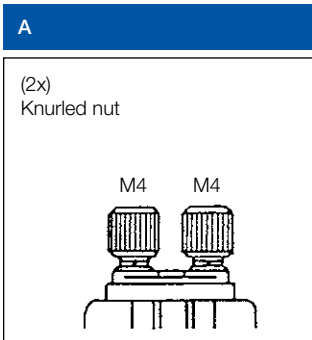

Part Number	Measuring range	Thread	Dimension		Type	bar
	[bar]		L1 [mm]	L2 [mm]		[max. 2 sec.]
360-081-032-011C	2	M12 x 1.5	20.5	12	C	30
360-081-032-025C	2	1/8" - 27 NPTF	19.5	11	C	30
360-081-032-058C	2	M18 x 1.5	20.5	12	A	30
360-081-032-001C	5	1/8" - 27 NPTF	19.5	11	A	30
360-081-032-002C	5	M10 x 1 tapered, short	19.5	11	A	30
360-081-032-007C	5	1/8" - 27 NPTF	19.5	11	B	30
360-081-032-013C	5	M18 x 1.5	20.8	12	A	30
360-081-032-016C	5	1/4" - 18 NPTF	23.8	15.3	A	30
360-081-032-059C	5	M18 x 1.5	20.5	12	D1	30
360-081-032-060C	5	M14 x 1.5	20.5	12	D1	30
360-081-032-003C	10	M10 x 1 tapered, short	19.5	11	A	30
360-081-032-004C	10	M12 x 1.5	20.5	12	A	30
360-081-032-006C	10	M14 x 1.5	20.5	12	A	30
360-081-032-008C	10	M18 x 1.5	20.5	12	A	30
360-081-032-014C	10	1/8" - 27 NPTF	19.5	11	A	30
360-081-032-053C	10	M12 x 1.5	20.5	12	A	30
360-081-032-057C	10	R1/8 DIN 2999	40	10	A	30
360-081-038-014C	16	M14 x 1.5	20.5	12	D1	30
360-081-038-001C	25	M14 x 1.5	20.5	12	D	50
360-081-038-002C	25	3/8" - 18 Dryseal NPTF	23.8	15.3	B	50
360-081-038-003C	25	1/8" - 27 NPTF	19.5	11	D	50
360-081-038-005C	25	M18 x 1.5	20.5	12	A	50
360-081-038-008C	28	1/8" - 27 NPTF	19.5	11	A	50
FOR DUAL UNITS (IDENTIFIER "D")						
362-081-001-001K*	5	1/8" - 27 NPTF	19.5	11	B	30
362-081-001-002C/K*	10	1/8" - 27 NPTF	19.5	11	B	30
362-081-002-001K*	25	1/8" - 27 NPTF	19.5	11	B	50
362-081-002-003C*	28	1/8" - 27 NPTF	19.5	11	A	50
362-081-002-004C*	28	1/8" - 27 NPTF	19.5	11	D	50

* Half characteristic map values

1 Without M4 hexagonal nut

Technical data	
Rated voltage	6–24 V
Operating temperature	-25 °C to +100 °C
Resistor range	10 Ω to 184 Ω

2.2.4 Pressure Sensor with Warning Contact (3 Connections)

Circuit diagram

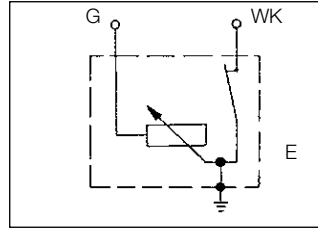
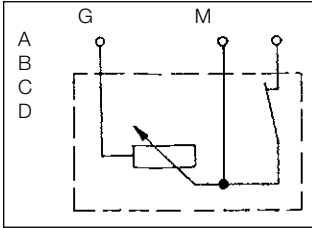

G = Sensor
M = Ground (Masse)
WK = Warning contact (Warnkontakt)

Type of connection

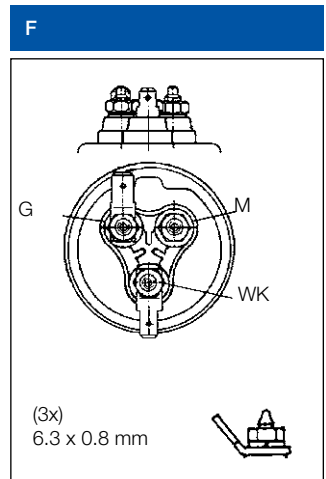
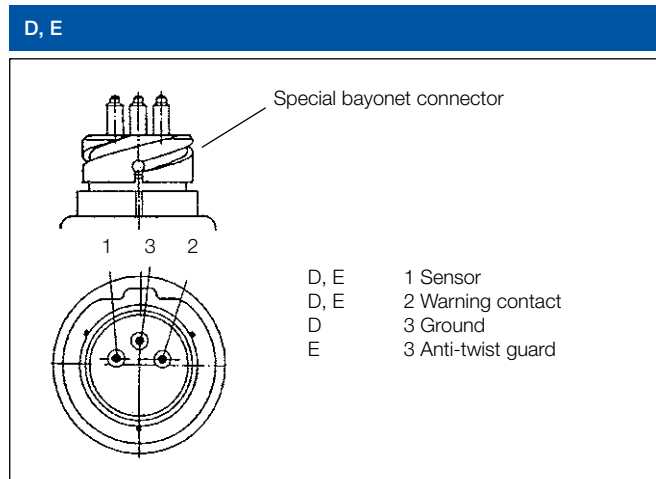
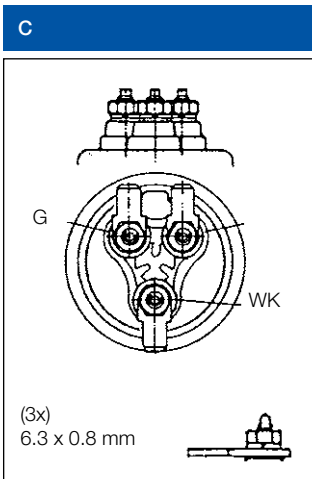
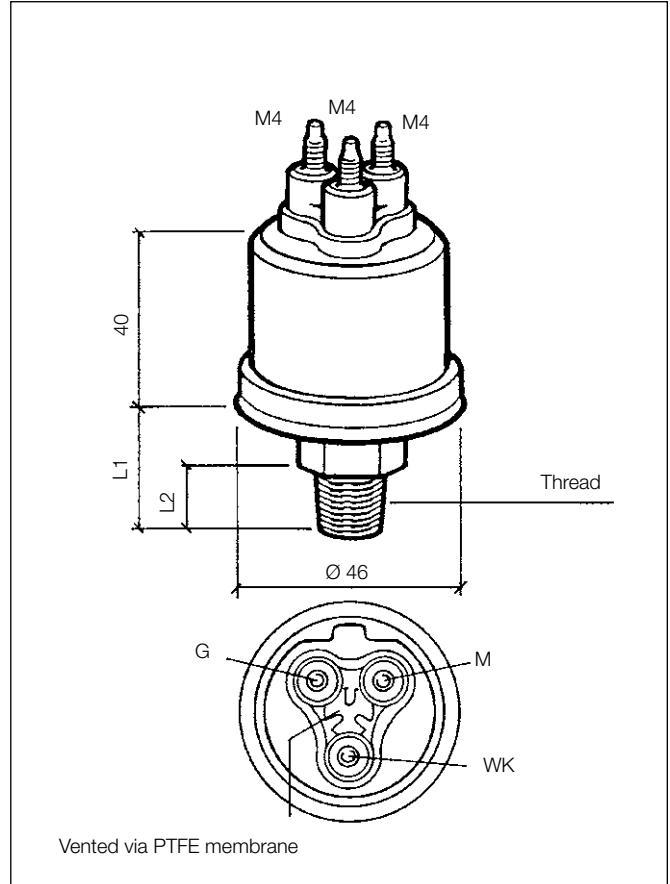
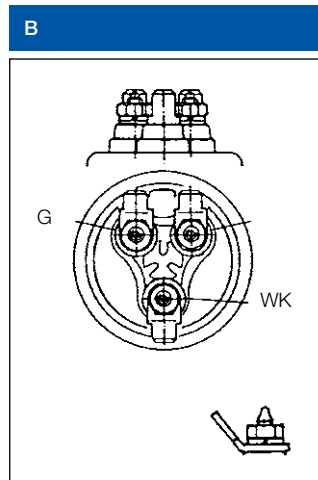
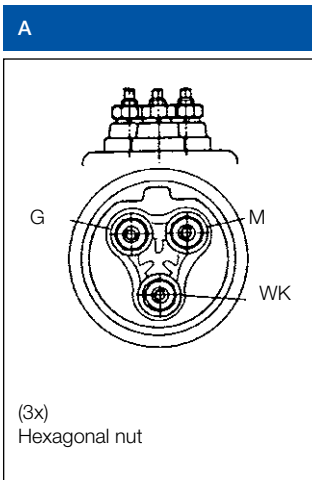

Part Number	Measuring range	Thread	Warning contact	Dimension		Type	bar
	[bar]		[bar]	L1 [mm]	L2 [mm]		[max. 2 sec.]
360-081-039-002C	5	1/8" - 27 Dryseal NPTF	0.8 ±0.15	19.5	11	B	30
360-081-039-015C	5	1/8" - 27 Dryseal NPTF	0.25 ^{+0.15}	19.5	11	B	30
360-081-064-001C	5	M18 x 1.5	0.25 ^{+0.15}	20.5	12	E	30
360-081-064-003C	5	M18 x 1.5	0.25 ±0.15	20.5	12	D, E	30
360-081-039-003C	10	1/8" - 27 Dryseal NPTF	0.8 ±0.15	19.5	11	B	30
360-081-039-007C	10	M14 x 1.5	1.0 ±0.15	20.5	12	A ¹	30
360-081-063-001C	10	M12 x 1.5	5.2 ±0.3	20.5	12	D	30
360-081-064-004C	10	M18 x 1.5	0.6 ^{+0.3}	20.5	12	E	30

*Supplied on request - limited availability

Part Number	Measuring range	Thread	Warning contact	Dimension		Type	bar
	[PSI]		[PSI]	L1 [mm]	L2 [mm]		[max. 2 sec.]
360-081-039-004C	80	1/8" - 27 Dryseal NPTF	10 ±2	19.5	11	C	30

¹Without M4 hexagonal nut

Technical data	
Rated voltage	6–24 V
Warning contact	Closes with falling pressure
Switching capacity of warning contact	Max. 5 W non-inductive
Operating temperature	-25 °C to +100 °C
Resistor range	10 Ω to 184 Ω



2.3 Pressure Switches

2.3.1 Pressure Switch, Single-Pole,
Common Ground

2.3.2 Pressure Switch,
Insulated Return

2.3.1 Pressure Switch, Single-Pole, Common Ground

Design 1

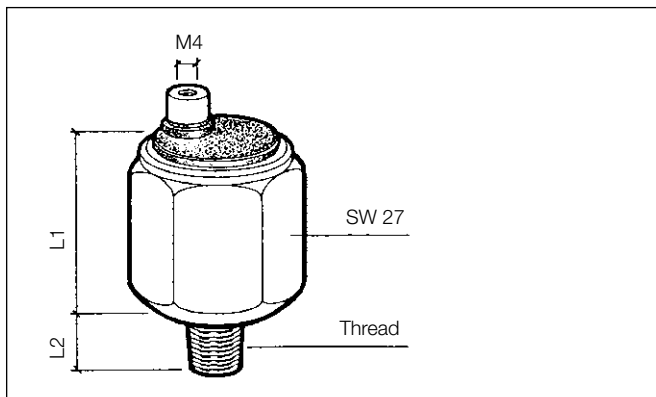

Design 2

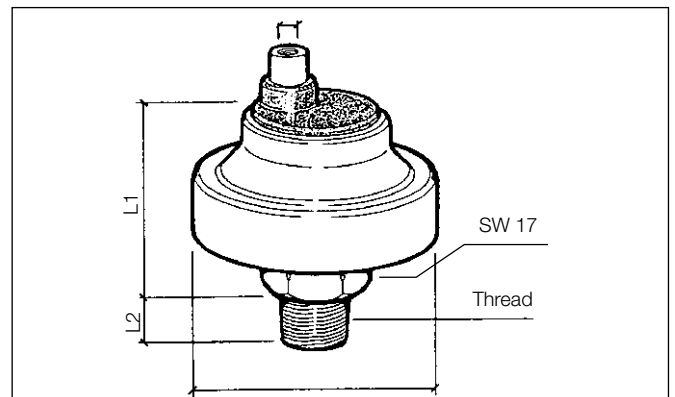

Type of connection

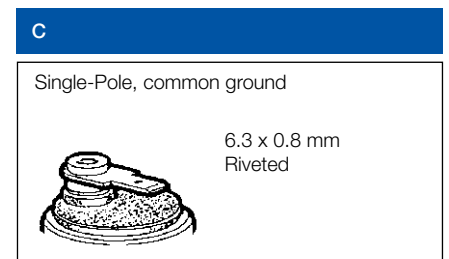
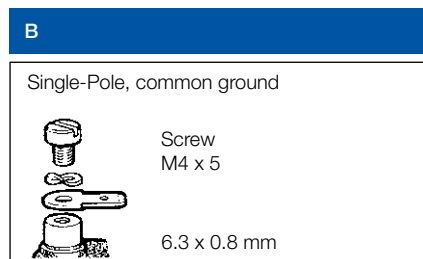
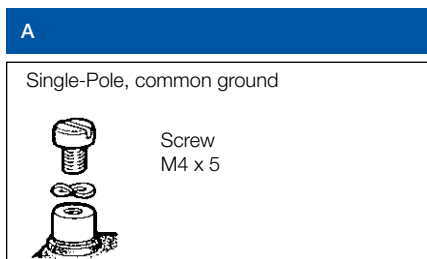

Part Number	Switch point		Thread	Dimension		Design / Type	Measuring range		bar
	[bar]			L1 [mm]	L2 [mm]		[bar]	[max. 2 sec.]	
230-112-005-004C	0.3 ± 0.3	SF	M10 x 1 tapered, short	26	10	1B	12	60	
230-112-001-004C	0.4 ± 0.3	SS	M10 x 1 tapered, short	26	11	1A ²	12	30	
230-113-001-004C	0.4 ± 0.2	SF	M10 x 1 tapered, short	39	11	2A ¹	12	30	
230-112-003-015C	0.5 ± 0.1	SF	M10 x 1 tapered, short	26	11	1A ¹	12	30	
230-112-005-005C	0.8 ± 0.2	SF	M10 x 1 tapered, short	26	10	1B	12	30	
230-112-001-015C	0.9 ± 0.15	OF	M10 x 1 tapered, short	26	11	1A ²	12	30	
230-112-003-022C	0.9 ± 0.15	SF	M10 x 1 tapered, short	26	11	1A ²	12	30	
230-112-001-001C	1.0 ± 0.2	SS	M10 x 1 tapered, short	26	11	1A ²	12	30	
230-112-005-001C	1.0 ± 0.2	SF	M10 x 1 tapered, short	26	10	1B	12	30	
230-112-001-005C	2.5 ± 0.3	SS	M10 x 1 tapered, short	26	11	1A ²	12	30	
230-113-001-008C	5.5 ± 0.2	SF	M12 x 1.5	39	12	2C ²	10	30	
230-213-001-021C	8.0 ± 0.5	SF	M10 x 1 tapered, short	39	11	2A ²	25	50	
230-213-001-011C	12.0 ± 0.4	SF	1/8" - 27 NPTF	39	11	2B ²	18	40	

¹Contact chamber, vented

²Contact chamber, unvented

Part Number	Switch point		Thread	Dimension		Type	Measuring range		PSI
	[PSI]			L1 [mm]	L2 [mm]		[PSI]	[max. 2 sec.]	
230-112-003-012C	6	SF	1/8" - 27 NPTF	26	11	1A1	12	30	
230-112-001-002C	10	SS	1/8" - 27 NPTF	26	11	1A1	12	30	
230-112-003-013C	10	SF	1/8" - 27 NPTF	26	11	1A1	12	30	

¹Contact chamber, unvented

Technical data

Rated voltage	6–24 V
Switching capacity	Max. 5 W non-inductive
Contacting mode	Slow-acting
Operating temperature	-25 °C to +120 °C
Switch point	SF = Contact closes with falling pressure SS = Contact closes with rising pressure OF = Contact opens with falling pressure OS = Contact opens with rising pressure

2.3.2 Pressure Sensor, Insulated Return

Design 1

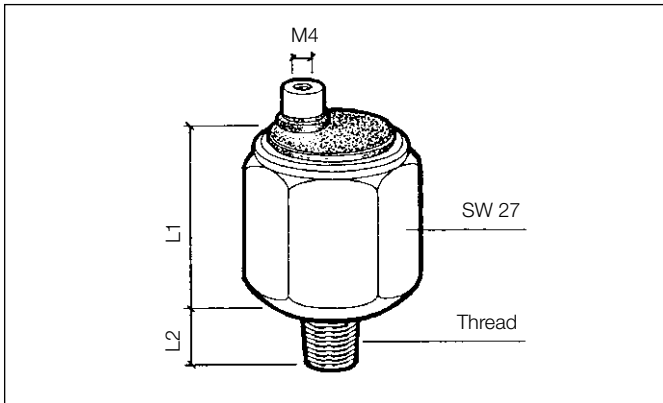

Design 2

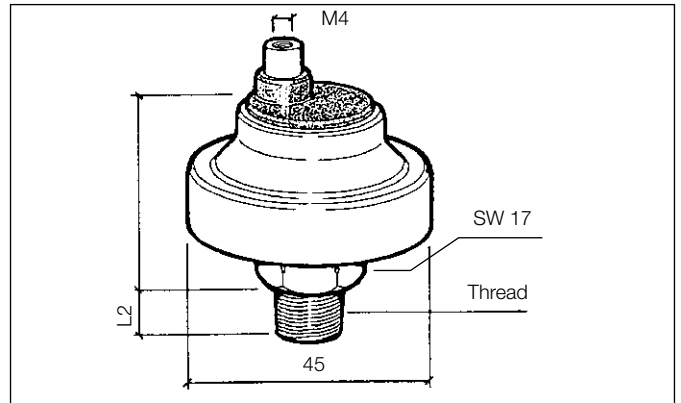

Type of connection

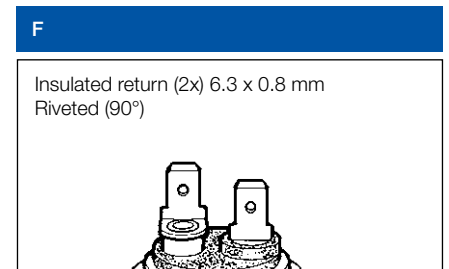
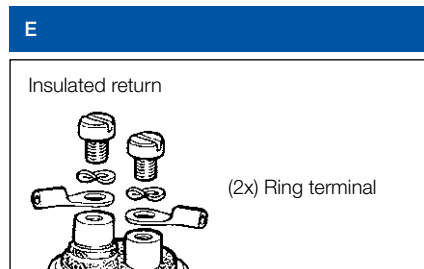
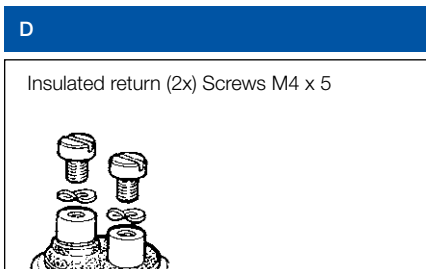

Part Number	Switch point		Thread	Dimension		Design / Type	Measuring range	bar
	[bar]			L1 [mm]	L2 [mm]		[bar]	
230-112-007-005C	0.3 ± 0.15	OS	M14 x 1.5-1	24.5	12	1F3	12	30
230-112-002-001C	0.5 ± 0.2	SS	1/8" - 27 NPTF	26	11	1D3	12	30
230-112-005-006C	0.5 ± 0.2	SF	M10 x 1 tapered, short	26	11	1F	12	30
230-112-005-005C	0.8 ± 0.2	SF	M10 x 1 tapered, short	26	11	1D2	12	30
230-112-005-001C	1.0 ± 0.2	SF	M10 x 1 tapered, short	26	11	1D2	12	30
230-112-005-012C	1.2 ± 0.2	SF	M10 x 1	24.5	10.5	1F	12	30
230-112-005-011C	1.5 ± 0.2	SF	M10 x 1 tapered, short	26	11	1E2	12	30
230-112-005-003C	1.8 ± 0.2	SF	M10 x 1 tapered, short	26	11	1E2	12	30
230-112-005-004C	3.0 ± 0.4	SF	M10 x 1 tapered, short	26	11	1D2	10	30
230-213-002-004C	4.5 ± 0.3	SF	M10 x 1 tapered, short	38	11	2D2	10	30
230-213-002-001C	7.0 ± 0.3	SF	1/8" - 27 NPTF	39	11	2E2	12	30
230-213-002-003C	10.5 ± 0.3	SF	1/8" - 27 Dryseal NPTF	39	11	2F	12	30
230-213-004-002C*	12.5 ± 0.4	SS	M14 x 1.5	39	12	1F	12	40

1 With sealing washer, captive

2 Contact chamber, vented

3 Contact chamber, unvented

* Supplied on request – limited availability

Part Number	Switch point		Thread	Dimension		Type	Measuring range	PSI
	[PSI]			L1 [mm]	L2 [mm]		[PSI]	
230-112-005-010C	7 ± 0.2	SF	1/8" - BSPF	26	10	1D1	12	30

1 Contact chamber, vented

Technical data	
Rated voltage	6–24 V
Switching capacity	Max. 5 W non-inductive
Contacting mode	Slow-acting
Operating temperature	-25 °C to +120 °C
Switch point	SF = Contact closes with falling pressure SS = Contact closes with rising pressure OF = Contact opens with falling pressure OS = Contact opens with rising pressure



2.4 Temperature Sensors

- 2.4.1 Temperature Sensor, Single-Pole, Common Ground
- 2.4.2 Temperature Sensor, Dual-Pole, Insulated Return
- 2.4.3 Temperature Sensor with IP Connectors
- 2.4.4 Temperature Sensor with Warning Contact
- 2.4.5 Temperature Sensor for Air Temperature
- 2.4.6 Temperature Sensor (special version)
- 2.4.7 Pyrometer Sensor

2.4.1 Temperature Sensor, Single-Pole, Common Ground

Type of connection

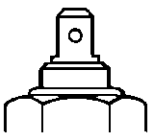
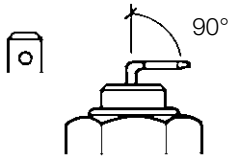
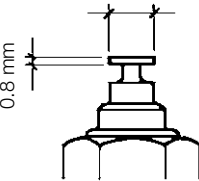
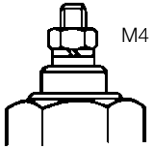
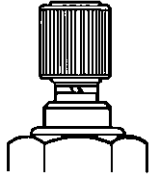
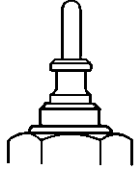
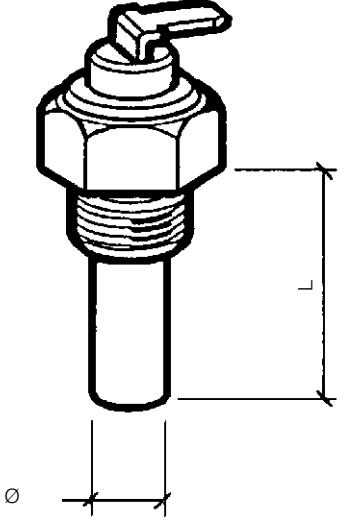
A	B	C	D
<p>Single-Pole, common ground 6.3 x 0.8 mm</p> 	<p>Single-Pole, common ground 6.3 x 0.8 mm</p> 	<p>Single-Pole, common ground Ø 6.3 mm</p> 	<p>Single-Pole, common ground Hexagonal nut M4</p> 
<p>Single-Pole, common ground Knurled nut, M4</p> 	<p>Single-Pole, common ground Ø 4 mm</p> 		

Technical data

Type	Thermistor (NTC)
Rated voltage	6–24 V
Temperature response time	Min. 3 minutes after operating current switched on

2.4.2 Temperature Sensor, Dual-Pole, Insulated Return

Type of connection

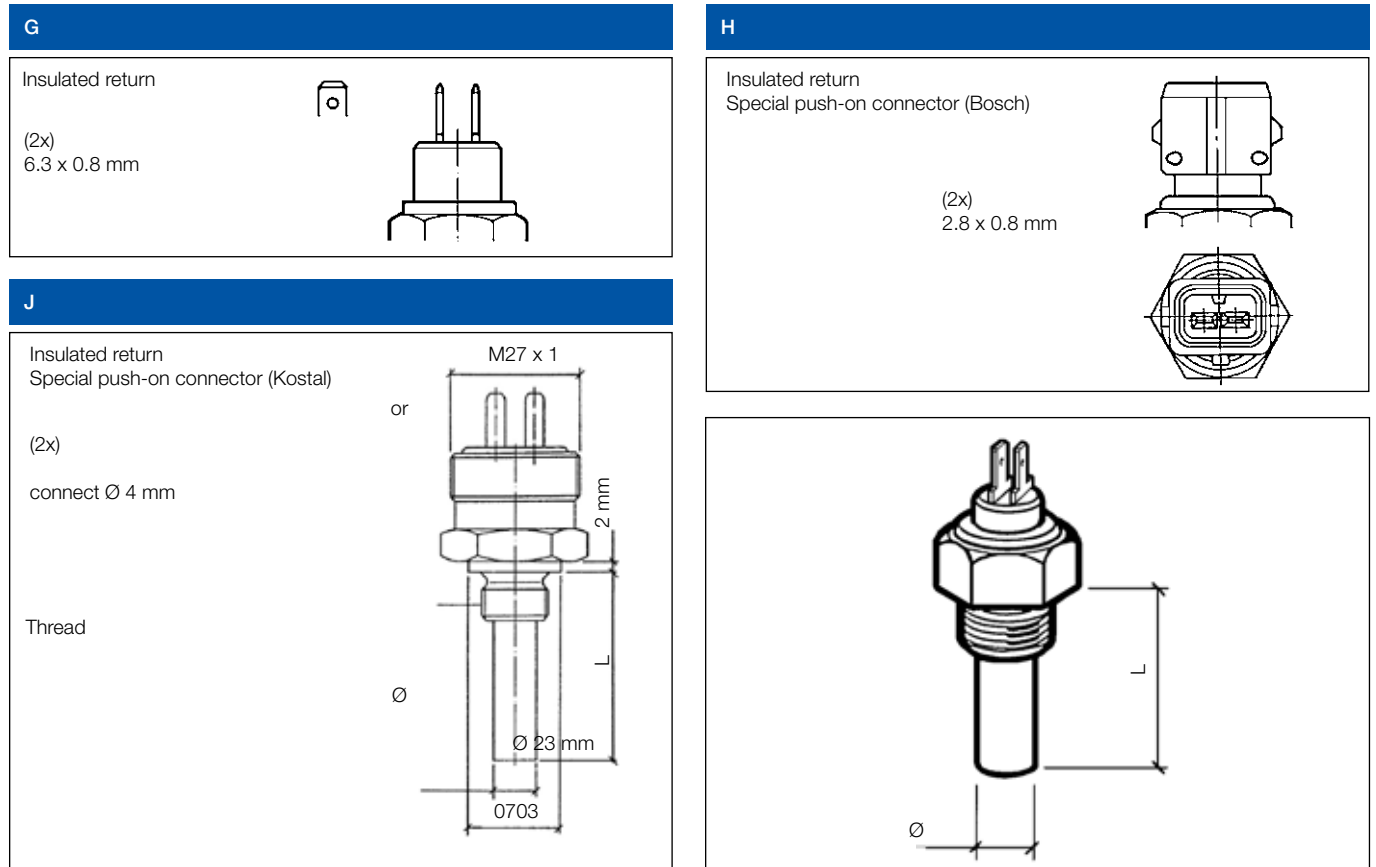

Part Number	T max.	Thread	Type	L	Ø
	[°C]			[mm]	[mm]
323-805-001-001K/N	120	M14 x 1.5	G	29	11
323-805-001-002C	120	5/8" - 18 UNF-2A	G	24	11
323-805-001-004K/N	120	1/2" - 14 NPTF	G	29	11
323-805-001-005N	120	3/8" - 18 Dryseal NPTF	G	29	11
323-805-001-015N	120	M18 x 1.5	G	29	9
323-805-034-002B	120	M14 x 1.5	H	29	7.5
323-805-039-001C	120	M14 x 1.5	H	29	8.5
323-805-042-001C	120	M14 x 1.5	H	29	8.5
323-808-002-003D*	120	M14 x 1.5	A (90°)	22	9
323-805-017-002C	130	M14 x 1.5		29	8.5
323-805-003-001N	150	M14 x 1.5	G	29	11
323-805-014-001B	150	M14 x 1.5	J	38	9
323-805-003-002N	150	1/4" - 18 NPTF	G	29	11
323-805-003-003N	150	5/8" - 18 UNF-2A with sealing cone	G	29	11

* Supplied on request - limited availability

FOR DUAL UNITS (IDENTIFIER "D")

325-805-003-001C	120	1/4" - 18 NPTF	G	29	10.9
325-805-003-003C	120	3/8" - 18 NPTF	G	29	10.9

Technical data

Type	Thermistor (NTC)
Rated voltage	6–24 V
Temperature response time	Min. 3 minutes after operating current switched on

Temperature Sensor with IP connectors (NTC-Technology)

General Description

Sensors for electronically controlled safety functions are the eyes, ears and the antenna of a modern-day high-tech vehicle. Nothing escapes them – neither lowest temperature deviations inside cooling systems nor monitoring of engine and gear oil temperature.

Intelligent safety systems are inconceivable without them.

Application

Temperature sensors based on are used in vehicles to record the temperature of oil, water or fuel and to forward the measurement result to ECU. The engine powertrain management system uses a number of temperature inputs to improve the performance of the engine, control emissions, fuel control and optimize efficiency.

Operating Principle

Temperature Sensor based on NTC-Technology (**N**egative **T**emperature **C**oefficient). It is a semi-conductor which changes the resistance value according temperature deviation. This resistance value as output value is rather indication of media medium temperature.

Key Features

- Wide range of applications
- High accuracy
- Long-term stability
- Certified quality
- High worldwide volume production

Applications

- Engine management
- Fan Control
- Temperature Display



Electrical Characteristics

Part-No.	A2C59900813	A2C59515306	A2C59515307	A2C59900816
Tightness conditions	IP6 9K, with counter connector. (IP6x for dust; IPx9K for water)	IP6 9K, with counter connector. (IP6x for dust; IPx9K for water)	IP6 9K, with counter connector. (IP6x for dust; IPx9K for water)	IP69K (With Bosch mating connector)
Connector	Bosch S204 714 - 000 2-pole CODE 2	Bosch S204 714 - 000 2-pole CODE 1	Kostal 1 00 50 54434 0 2-pole code A	Tyco C 282 190
Mating Connector	Bosch 1928403920 code2 contact 2	Delphi DRW. 152624 way2 code 1	Leopold Kostal receptacle housing (black) 2 pole Code A, 09 4412 11 Contact SLK 8 ELA TAB 2 99 00 47295 0	Tyco AMP925597-2 or AMP925596
Resistance Characteristic	60°C: 7556 ± 378,0 Ω 90°C: 2803,6 ± 140,2 Ω 120°C: 1191 ± 59,5 Ω 150°C: 562,7 ± 36,0 Ω	60°C: 546,7 ± 23,6 Ω 90°C: 205,4 ± 10,2 Ω 120°C: 88,2 ± 5,0 Ω	60°C: 593,8 ± 19,3 Ω 90°C: 244,1 ± 4,7 Ω 120°C: 113,7 ± 3,0 Ω	60°C: 703,8 ± 40,9 Ω 90°C: 260,7 ± 15,1 Ω 120°C: 111,1 ± 7,8 Ω

Performance Characteristics

Part-No.	A2C59900813	A2C59515306	A2C59515307	A2C59900816
Temperature Range	- 40°C to + 150°C	- 40°C to + 140 °C	- 40°C to + 130°C (+ 150°C max 10 min)	- 40°C to + 130°C
Media to be sensed	Engine oil, Engine coolant, Diesel fuel	Engine coolant	Engine coolant	Engine coolant
Recommended Application	Truck Bus Generators	Passenger Generator	Truck, Bus, Generators Medium Marine Engines	Passenger Generators Motorcycles Small Marine Engines

Mechanical Characteristics

Part-No.	A2C59900813	A2C59515306	A2C59515307	A2C59900816
Contact Socket	PA 66 GF 30 / Grey	PA 66 GF 30 / Black	PA 6.6 GF 25 / Black	PA 66 GF 30 / Blue
Connecting Piece	11SMnPb30	CuZn39Pb3 R430	CuZn39Pb2F43	11sMnPb30
SW	Hex21	Hex21	Hex22	Hex21
Thread	M12 x 1,5	M12 x 1,5	M14 x 1,5	M12 x 1,5
Weight	23 g	25 g	41 g	29 g
O-Ring	FMP (Shore A 70 + -5)	Copper	None	EN AW - 1200 (Al 99)
Tightening Torque	From 15 Nm to 20 Nm	17 Nm + 3 Nm - 0 Nm	Max 45 Nm	20 Nm ± 10%

2.4.3 Temperature Sensor with Warning Contact

Type of connection

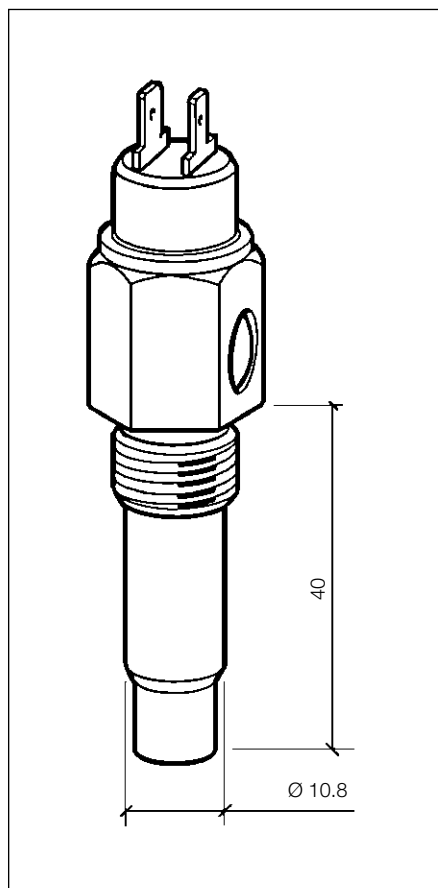
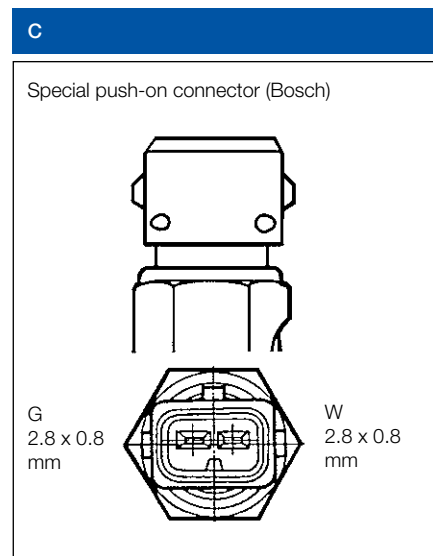
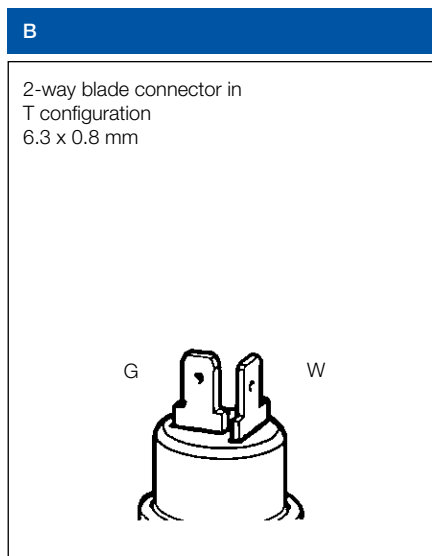
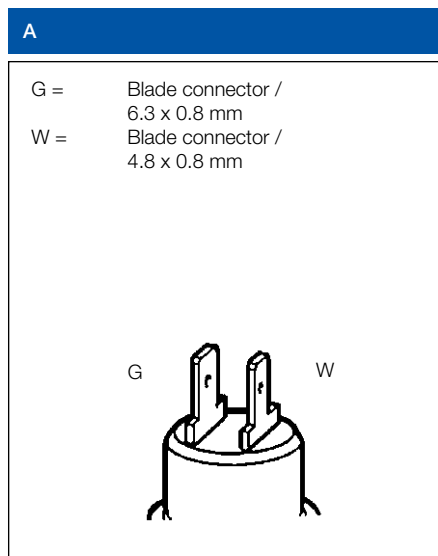

G = Sensor terminal
W = Warning contact terminal

Technical data	
Type	Thermistor (NTC)
Rated voltage	6–24 V
Temperature response time	Min. 3 minutes after operating current switched on
Switching capacity	1.2 W to 3 W, non-inductive
Switch-off point	Max. 5 °C below switch-on point
Contacting mode	Slow-acting
Contact type	Normally open
	Contact closes with rising temperature

Part Number	T max.	Thread	Switch-on point	Type
	[°C]		[°C]	
323-803-001-001D	120	M14 x 1.5	100 ±3	A
323-803-001-002D	120	5/8" - 18 NF-3	98 ±3	A
323-803-001-004D	120	M14 x 1.5	90 ±3	A
323-803-001-006D	120	M14 x 1.5	96 ±3	A
323-803-001-007D	120	M14 x 1.5	110 ±3	A
323-803-001-008D	120	M14 x 1.5	110 ±3	A
323-803-001-009D	120	M14 x 1.5	102 ±3	A
323-803-001-011D	120	5/8" - 18 NF-3	95 ±3	A
323-803-001-012D	120	5/8" - 18 NF-3	100 ±3	A
323-803-001-013D	120	M14 x 1.5	106 ±3	A
323-803-001-016D	120	M14 x 1.5	94 ±3	A
323-803-001-019D	120	1/2" - 14 NPTF	95 ±3	A
323-803-001-020D	120	M14 x 1.5	115 ±3	A
323-803-001-022D	120	M14 x 1.5	118 ±3	A
323-803-001-023D	120	M14 x 1.5	80 ±3	A
323-803-001-025D	120	1/2" - 14 NPTF	103 ±3	A
323-803-001-028D	120	M14 x 1.5	98 ±3	A
323-803-001-030D	120	1/2" - 14 NPTF	100 ±3	A
323-803-001-032D	120	1/2" - 14 NPTF	108 ±3	A
323-803-001-036D	120	5/8" - 18 NF-3	103 ±3	A
323-803-001-059D	120	5/8" - 18 NF-3	105 ±3	A
323-803-001-060D	120	1/2" - 14 NPTF	105 ±3	A
323-803-001-064C	120	M14 x 1.5	112 ±3	A
323-803-004-001D	120	M14 x 1.5	100 ±2.5	B
323-803-004-002D	120	M14 x 1.5	105 ±3	B
323-803-004-003D	120	M14 x 1.5	95 ±2.5	B
323-803-004-007D	Fuel-Filter	M14 x 1.5	100 ⁺⁶	B
323-803-004-011D	120	M14 x 1.5	105 ±3	A (90°)
323-803-002-002D	150	M14 x 1.5	120 ±3	A
323-803-002-007D	150	M14 x 1.5	130 ±3	A
323-803-002-010C	150	M14 x 1.5	135 ±3	A
323-803-002-016D	150	M14 x 1.5	130 ±3	A
323-803-002-017D	150	M14 x 1.5 ¹	120 ±3	A
323-803-002-019D	150	M14 x 1.5	135 ±3	A
323-803-002-020D	150	M14 x 1.5	110 ±3	A
323-803-006-002C	150	M14 x 1.5	130 ±4	B
323-803-014-002D	150	M14 x 1.5	130 ±3	A
323-803-014-007C	150	M14 x 1.5 ¹	108 ±3	D

¹With sealing ring, captive

*Supplied on request - limited availability

CONNECTION FOR TEMPERATURE SENSOR

Part Number	Internal thread	External thread
A2C59517951	14x1.5 mm	1/2" - 14NPTF
A2C59517952	14x1.5 mm	3/8"

2.4.4 Temperature Sensor for Air Temperature

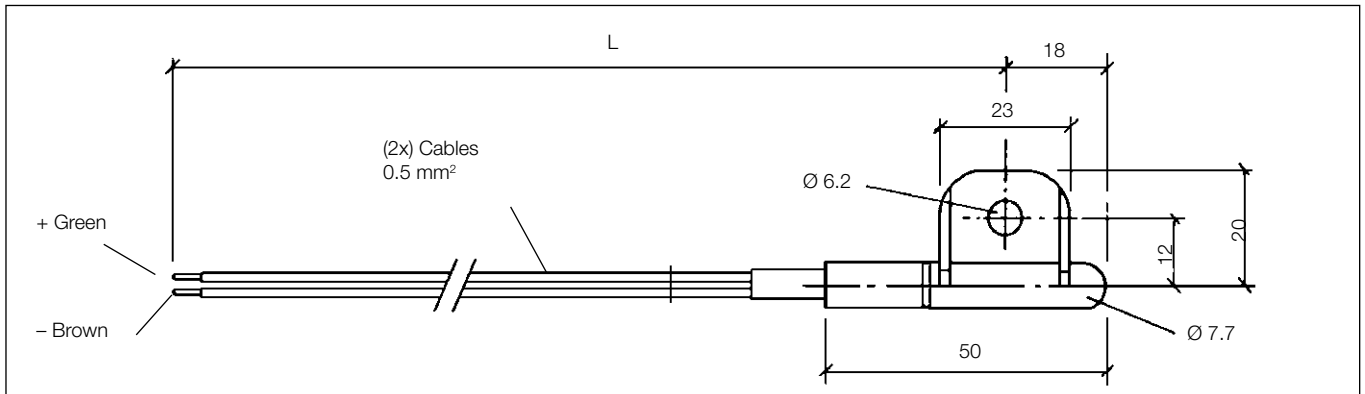

Part Number	Products
323-809-010-005C	Cable length L: 3,000 mm
323-809-010-006C	Cable length L: 4,500 mm

Technical data	
Type	Thermistor (NTC), insulated return
Rated voltage	6–24 V
Operating temperature	-40 °C to +85 °C max.
Temperature response time	Min. 3 minutes after operating current switched on

WITH PROBE TIP

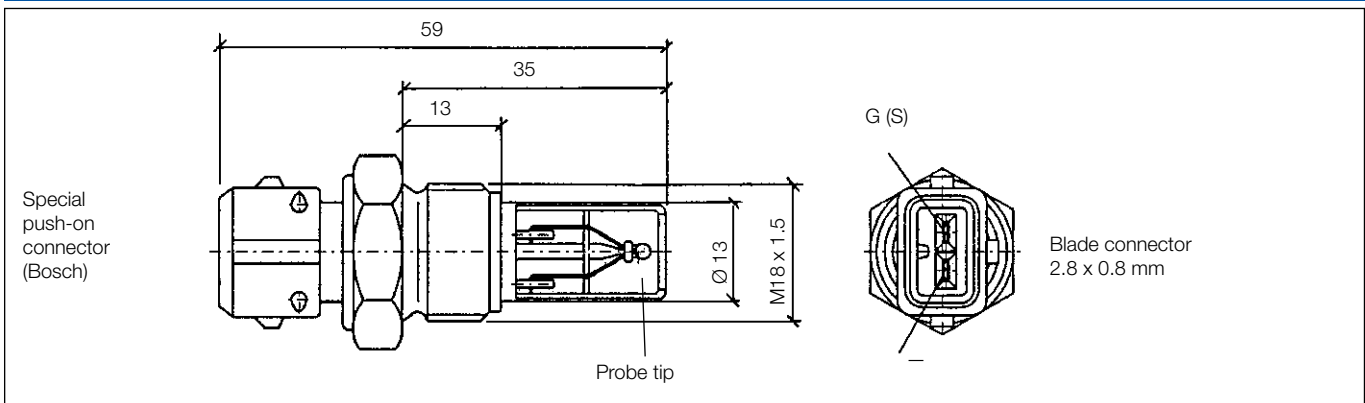

Part Number: 323-809-019-003A

Technical data	
Type	Thermistor (NTC), insulated return
Rated voltage	6–24 V
Operating temperature	-40 °C to +150 °C max. at probe tip
Temperature response time	Min. 3 minutes after operating current switched on

2.4.5 Temperature Sensors (Special version)

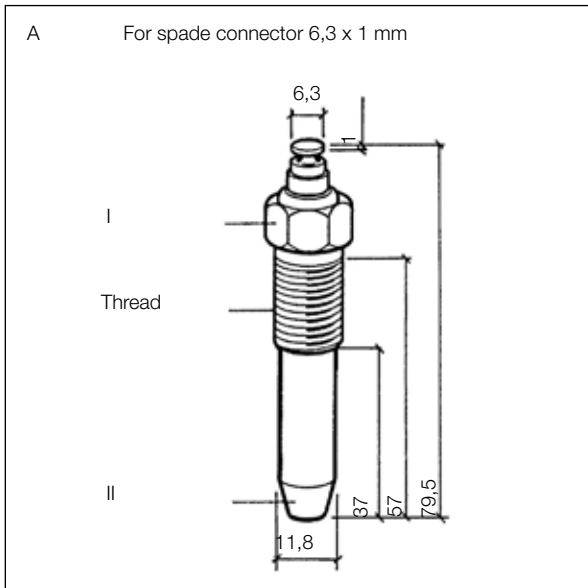

Technical data

Version	Thermistor, 1-pole common ground
Rated voltage	6V to 24V
Temperature response time	3 minutes minimum after switching on operating current
Operating value	Operation with indicating instrument: 210°C = 18.9Ω ± 1.3Ω Operation with control electronics: 210°C = 20.05Ω ± 0.80Ω

Operating temperature		Thread	CT	Type	Part number
Measuring point I	Measuring point II				
-40°C ... +150°C	-40°C ... +250°C	M14 x 1,5	14	A	323-801-028-001C

2.4.6 Pyrometer Sensor

Dimensions of sensor (mm):

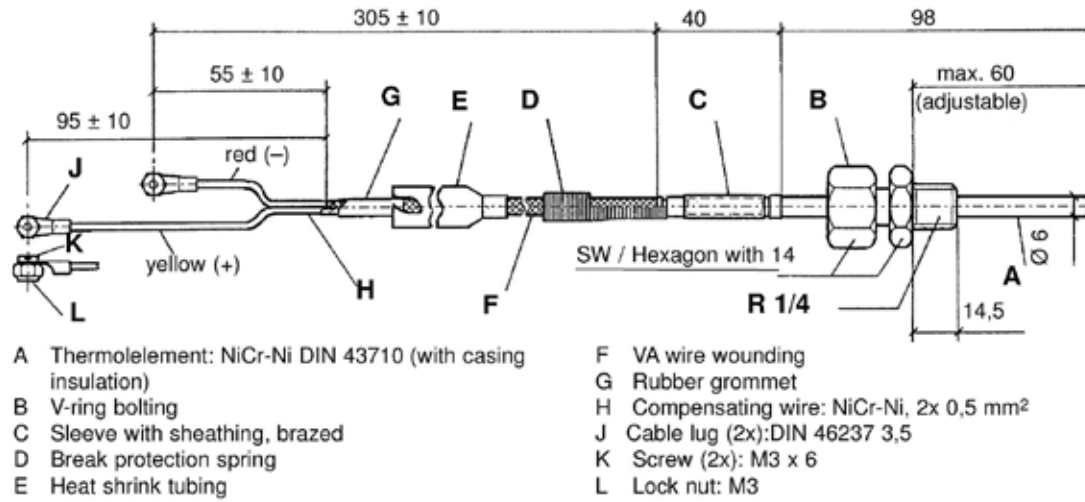

Part Number: N03-320-264

Dimensions of connecting cable:

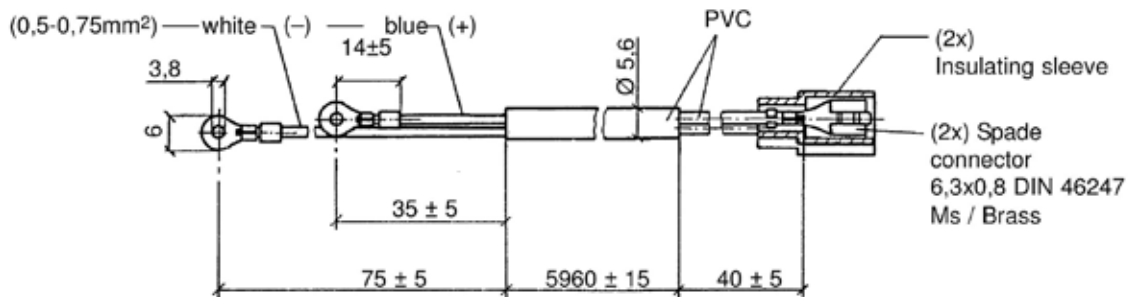

Part Number: N03-320-268

Dimensions of threaded bushing (steel) for welding to manifold:

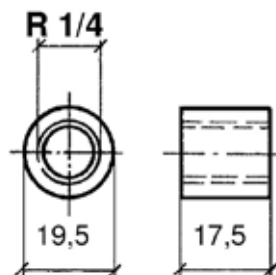

Part Number: N03-320-266



2.5 Temperature Switches

2.5.1 Temperature Switch, Single-Pole,
Common Ground

2.5.2 Temperature Switch, Dual-Pole,
Insulated Return

2.5.1 Temperature Switch, Single-Pole, Common Ground

Type of connection

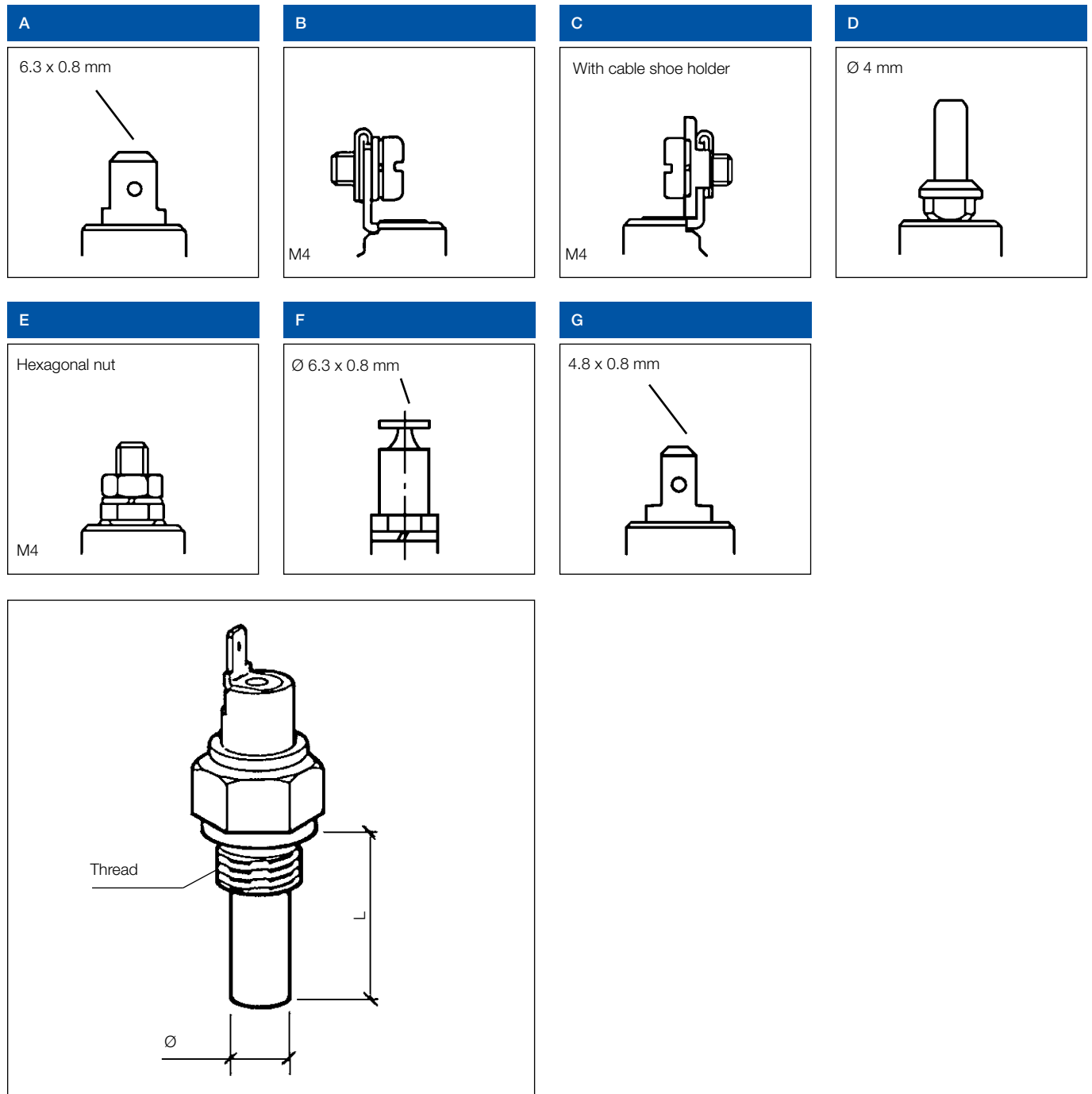

Part Number	Switch-on point	Switch mode	Thread	T max.	Type	L	Ø
	[+ °C]			[°C]		[mm]	[mm]
232-011-020-022E	16 ±3 (normally closed, NC)	OS	M14 x 1.5	120	D	29	10
232-011-020-006E	25 ±3 (normally closed, NC)	OS	M14 x 1.5	120	D	29	10
232-011-017-141D	28 ±3 (normally closed, NC)	OS	M14 x 1.5	120	A	29	9.7
232-011-017-129D	35 ±3	SS	M14 x 1.5	120	A	29 ±0.2	10-0.5
232-011-005-019D	96 ±3	SS	1/8" - 27 Dryseal NPFT	120	E	33 ±0.5	12 ±0.3
232-011-017-148D	35 ±3	SS	M14 x 1.5	120	A	29	10
232-011-017-087D	40 ±3	SS	M14 x 1.5	120	D	29	10
232-011-017-038D	55 ±3	SS	M14 x 1.5	120	A	29	10
232-011-017-040D	70 ±3	SS	M14 x 1.5	120	A	29	10
232-011-017-078D	80 ±3	SS	M14 x 1.5 tapered, short	120	A	29	10
232-011-017-017D	85 ±3	SS	M14 x 1.5	120	A	29	10
232-011-005-003D	90 ±3	SS	M14 x 1.5	120	E	38.5	6.9
232-011-017-013D	90 ±3	SS	M10 x 1.5 tapered, short	120	A	29	10
232-011-017-033D	92 ±3	SS	M14 x 1.5	120	A	29	10
232-011-017-147D	94 ±3	SS	M14 x 1.5	120	D	29	10
232-011-017-016D	95 ±3	SS	M14 x 1.5	120	A	29	10
232-011-017-039D	95 ±3	SS	1/2" - 14 NPTF	120	A	29	10
232-011-017-080D	97 ±3	SS	M14 x 1.5	120	A	29	10
232-011-017-099D*	98 ±3	SS	5/8" - 18 UNF-2A	120	A	29	10
232-011-017-034D	100 ±3	SS	M14 x 1.5	160	A	29	10
232-011-017-058D*	102 ±6	SS	M14 x 1.5	120	C	29	10
232-011-017-135D	102 ±3	SS	M14 x 1.5	150	D	29 ±0.2	9 ±0.2
232-011-017-139D	103 ±3	SS	3/8" - 18 NPTF	120	A	29	10
232-011-017-037D	105 ±3	SS	M14 x 1.5	120	A	29	10
232-011-017-041D	105 ±3	SS	1/2" - 14 NPTF	120	A	29	10
232-011-017-145D*	105 ±3	SS	3/8" - 18 NPTF	120	G	29	10
232-011-017-010D	110 ±3	SS	M14 x 1.5	160	A	29	10
232-011-017-076D	115 ±3	SS	M14 x 1.5	130	A	29	10
232-011-017-005D	120 ±3	SS	1/2" - 14 NPTF	130	B	29	10
232-011-017-032D	120 ±3	SS	M14 x 1.5	130	A	29	10
232-011-017-143D	120 ±3.3	SS	3/4" - 16 UNF-2A	150	A	27.1 ±0.2	9.7 ±0.2
232-011-017-103D	130 ±3	SS	M14 x 1.5	150	A	29	10
232-011-005-004D	140 ±10	SS	M14 x 1.5	160	A	29	10
232-011-017-004D	140 ±10	SS	M14 x 1.5	160	A	29	10
232-011-005-017D	150 ±5	SS	M10 x 1.5	200	E	38.5	6.9
232-011-005-027D	150 ±5	SS	M10 x 1.5	200	F	38.5	6.9

Part Number	Switch-on point	Switch mode	Thread	T max.	Type	L	Ø
	[+ °C]			[°C]		[mm]	[mm]
232-011-005-004D	170 ±5	SS	M10 x 1.5	220	E	38.5	6.9
232-011-005-028D	170 ±5	SS	M10 x 1.5	220	F	38.5	6.9
232-011-005-030D	185 ±5	SS	M10 x 1.5	230	F	38.5	6.9
232-011-019-003D	195+10	SS	M10 x 1.5	250	E	38.5	6.9

*Supplied on request - limited availability

Technical data	
Switching capacity	1.2 W to 3 W, non-inductive
For monitoring various fluids	
Rated voltage	6–24 V
Contact type	Normally open
Switch-off point	Max. 5 °C below switch-on point
Contacting mode	Slow-acting
Type of contact	SS = contact close as temperature rises OS = contact open as temperature rises

2.5.2 Temperature Switch, Dual-Pole, Insulated Return

Design

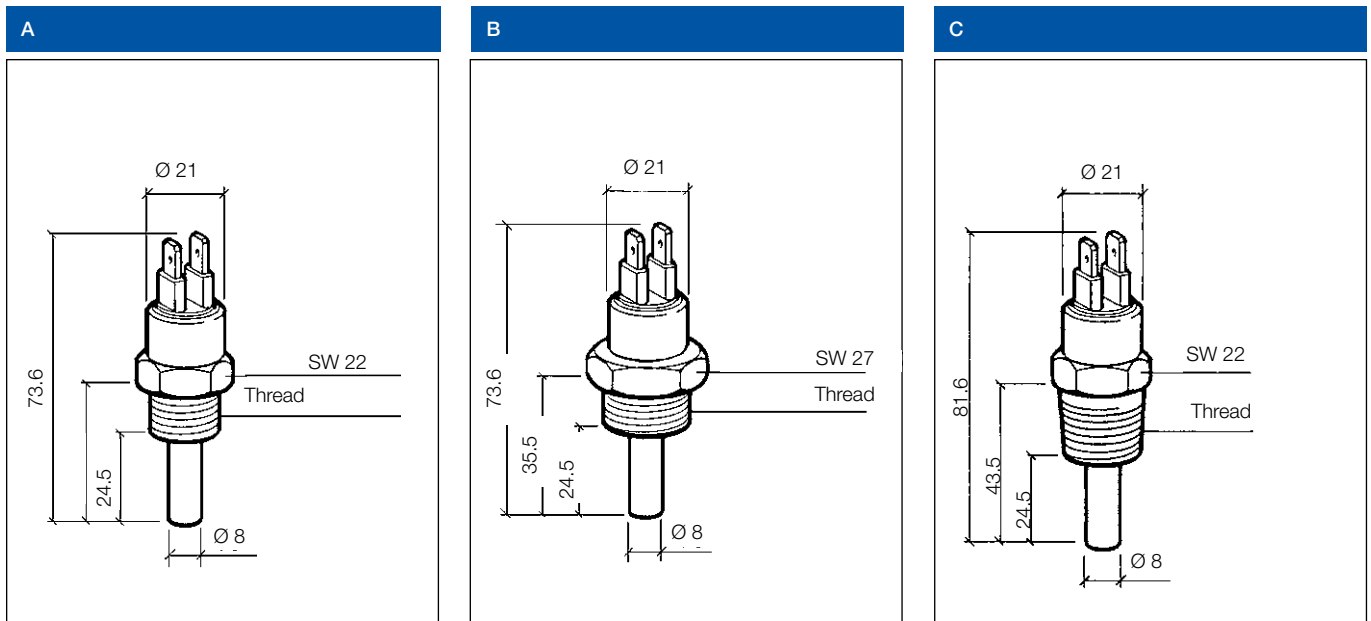

Part Number	Switch-on point	Switch-off point	Thread	Design
	[+ °C]	[+ °C]		
232-036-005-019C*	35 ± 4 (normally closed, NC)		M14 x 1.5	
X10-232-001-001	64 ± 3	60 ± 3	M14 x 1.5	A
X10-232-001-002	82 ± 3	74 ± 3	M18 x 1.5	A
X10-232-001-003	86 ± 3	81 ± 3	M18 x 1.5	A
X10-232-001-004	92 ± 3	85 ± 3	M18 x 1.5	A
X10-232-001-005	96 ± 3	92 ± 3	M18 x 1.5	A
X10-232-001-006	96 ± 3	91 ± 3	1/2" - 14 NPTF	C
X10-232-001-007	96 ± 3	92 ± 3	M14 x 1.5	A
X10-232-001-008	96 ± 3	92 ± 3	M22 x 1.5	B
X10-232-001-009	100 ± 3	95 ± 3	M18 x 1.5	A
X10-232-001-010	105 ± 3	100 ± 3	M18 x 1.5	A

*Supplied on request - limited availability

Technical data	
Switching capacity:	100 W
FOR MONITORING VARIOUS FLUIDS	
Operating temperature	Max. 110 °C
Rated voltage	6–24 V
Switch-on point	Normally open Contact closes with rising temperature
Switch-off point	Max. 5 °C below switch-on point
2-way blade connector	A 6.3 x 0.8 mm, DIN 46244



2.6 Liquid Level Switches

2.6.1 Liquid Level Switch,
Linear Type, Oil/Diesel

2.6.2 Liquid Level Switch,
Lever Type, Water

2.6.1 Liquid Level Switch, Linear Type, Oil/Diesel

Dimensions [mm]

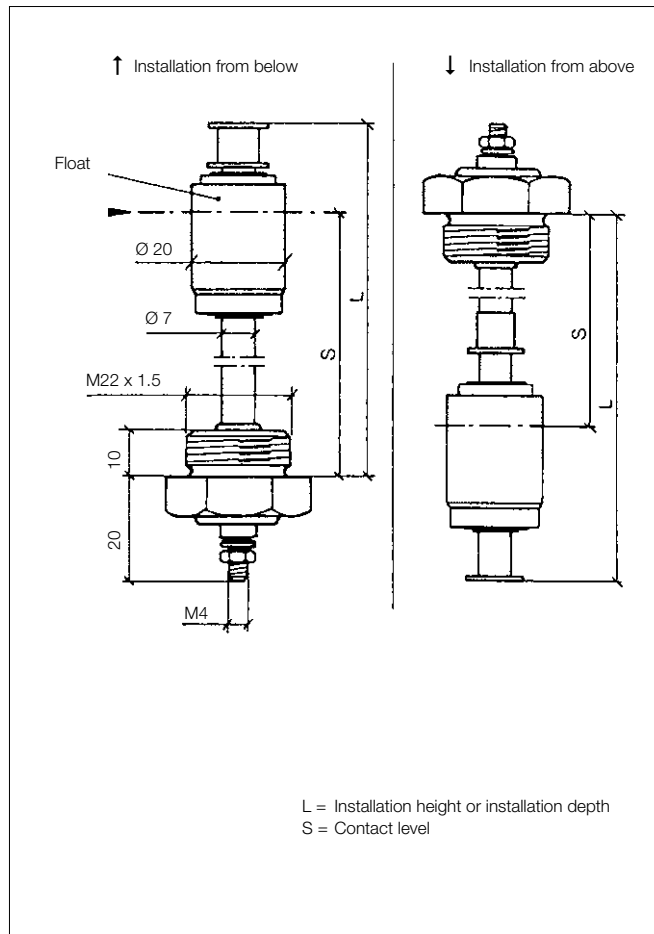

Type of connection

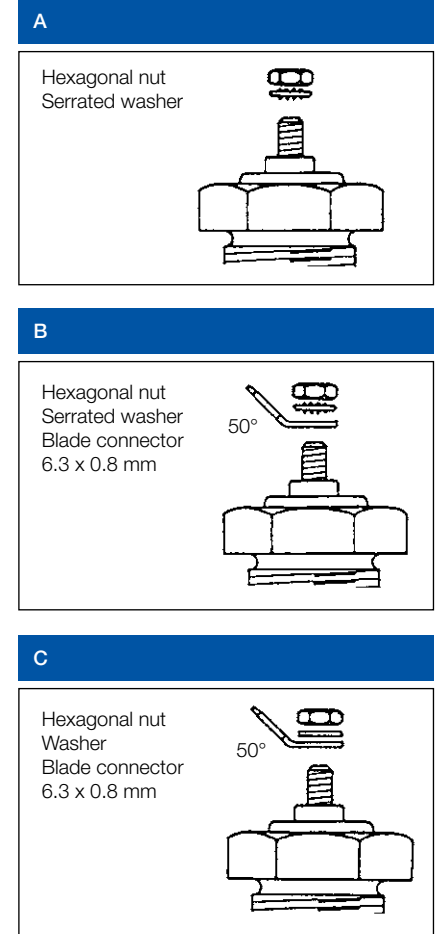

Part Number	Installation	L	S	Voltage	Switching capacity	Type	Fluid
		[± 1.5 mm]	[± 3 mm]				
395-462-001-001G	↓	184	158	24 V	3 W	A	Diesel/transmission oil
395-262-001-007C	↓	196	170	12 V	2 W	B	Diesel
395-262-001-023C	↓	275	249	12 V	2 W	B	Diesel
395-462-001-006G	↓	311	285	24 V	3 W	C	Diesel
395-262-001-013G	↓	346	320	12 V	2 W	B	Diesel
395-462-001-002G	↑	60.6	35.6	24 V	3 W	A	Diesel
395-262-001-005G	↑	75	50	12 V	2 W	B	Diesel
395-262-001-016G	↑	77.5	52.5	12 V	2 W	B	Diesel
395-262-001-015G	↑	98	73	12 V	2 W	A	Diesel
395-462-001-004G	↑	145	120	24 V	3 W	B	Diesel
395-462-001-005C	↑	175	150	24 V	3 W	B	Diesel

Technical data

Electrical connection	Single pole, common ground
Rated voltage	12 V or 24 V
Switching capacity	2 W or 3 W
Contacting mode	Contact closes with falling pressure
Limiting current value	150 mA
Operating temperature	-30 °C to +100 °C

2.6.2 Liquid Level Switch, Lever Type, Water

Dimensions [mm]

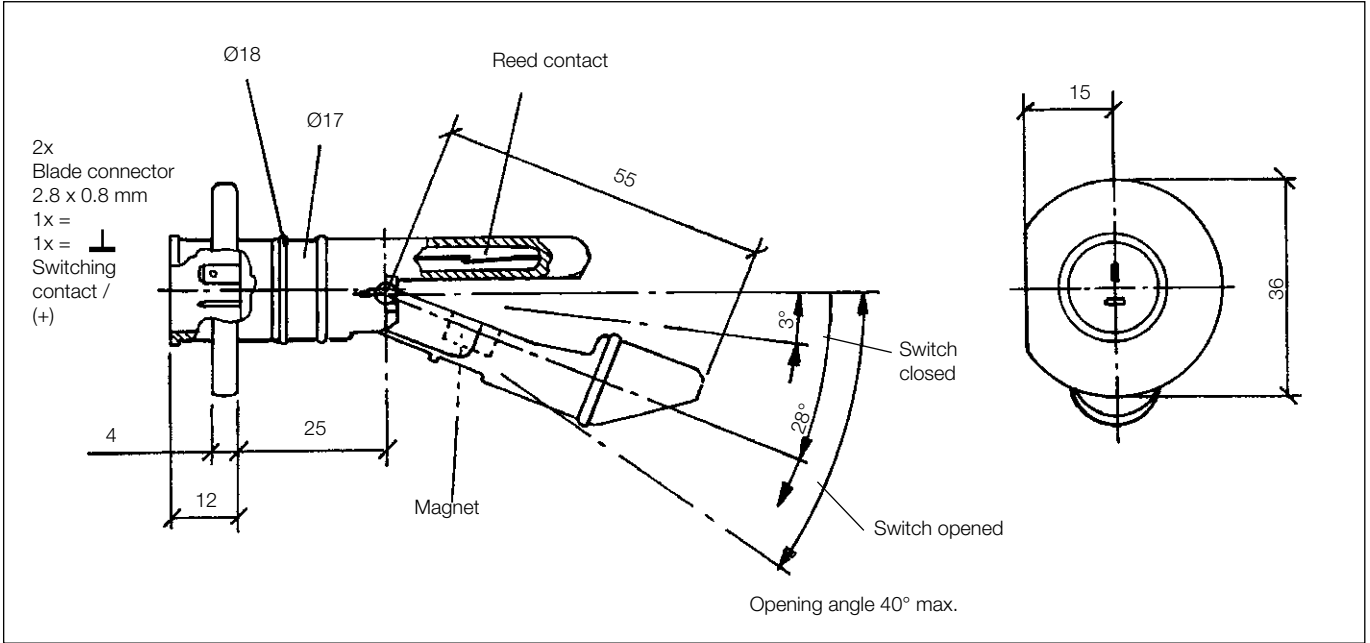

Part Number	Products
395-060-017-002C	Liquid level switch
X11-000-002-173	Accessories: Sealing sleeve

Technical data	
Rated voltage	24 V
Switching capacity	3 W
Contacting mode	Normally closed
Operating temperature	-30°C to $+100^\circ\text{C}$
Fluid	Screenwash/coolant
Resistant to	50% ethanol + 50% H ₂ O
or	50% methanol + 50% H ₂ O
or	50% anti-freeze (e.g., Glysantin) + 50% H ₂ O

Pressure tight to 1.5 bar max.



2.7 Customer-Specific Solutions Sensors for Engine Management Systems

- 2.7.1 Intake Air Pressure Sensors (MAP, T-MAP)
- 2.7.2 Mass Airflow Sensor (MAF)
- 2.7.3 Knock Sensor
- 2.7.4 Crankshaft Position Sensor
- 2.7.5 Camshaft Position Sensor
- 2.7.6 High temperature Sensor (HTS)
- 2.7.7 Electronic Pressure Sensor (EPS)



2.7.1 Electronic Pressure Sensor (EPS)

The new EPS sensor (Electronic Pressure Sensor) is a high-performance successor to the previous generation of passive, electromechanical sensors. Combining modest weight and dimensions with enhanced precision, the EPS sensor represents the future of pressure sensing.

This innovative device uses the piezoresistive effect, i.e. changes in resistivity, to convert system pressure into a proportional output signal. Depending on the choice of seal material, the EPS sensor offers excellent resistance against a wide range of media, e.g. oil, brake fluid, diesel, petrol and engine coolant. The EPS sensor was specially designed for high-precision monitoring of engine oil, transmission oil, hydraulic and air pressures. In addition to conventional automotive applications, the sensor is thus ideal for off-road vehicles as well as hydraulic and pneu-

matic systems. The screw-type fitting can be adapted to individual customer requirements. The sensor connects to the rest of the vehicle electronics via cable and plug.

Product benefits:

- Direct pressure sensing.
- Compatible with a wide range of media.
- Modular design.
- Customer-specific threaded fitting possible.
- Customer-specific pressure range possible.



Electronic Pressure Sensor

Technical Specification:	
Pressure Range:	10 bar ... 200 bar (Al-fitting, crimped connection PSM-to-fitting)
Option Pressure Range:	200 bar ... 600 bar (Stainless steel fitting, welded PSM-to-fitting)
Medium*:	Air, engine oil, gear oil
Supply Voltage (Vs):	8 VDC to 32 VDC
Output Signal:	0.5 V ... 4.5 V
Temperature Range:	- 40 °C to +125 °C
Environmental protection:	IP 6K9K
Electrical Connector Type:	Bayonet according to ISO15170 (formerly DIN 72585)

* Depending on annual volume further media resistances feasible

Part number	Pressure ranges
365-100-010-121C	0 - 10 bar
365-100-016-121C	0 - 16 bar
365-100-030-121C	0 - 30 bar

* Only available for series production applications on request



2.7.2 Intake Air Pressure Sensors (MAP, T-MAP)

Temperature and absolute pressure sensors, 1 to 5 bar

Our innovative sensors help to meet increased global requirements with regard to enhanced performance, as well as current and future emissions regulations. Absolute pressure sensors are used to measure air pressure in different applications throughout the vehicle.

Operating principle

Our absolute pressure sensors are based on micro-machined silicon sensing elements, which deflect under load to generate a ratiometric voltage that corresponds to the incident pressure. This signal is in turn amplified and temperature-compensated according to a fully configurable digital calibration.



MAP sensor



BAP sensor



Applications

- MAP (**Manifold Absolute Pressure** Sensor): Measurement of intake air pressure in order to measure air flow, which is an important variable in calculating the volume of fuel to be injected and, in turn, for optimization of the air-fuel mixture.
- T-MAP (**MAP** Sensor with integral Temperature Sensor): Measurement of intake air pressure and temperature in order to measure air flow, which is an important variable in calculating the volume of fuel to be injected and, in turn, for optimization of the air-fuel mixture.
- Turbo MAP (**Manifold Absolute Pressure** Sensor for Turbocharged engines): Measures air pressure, for example, downstream of the turbocharger.
- Turbo T-MAP (**Turbo MAP** Sensor with integral Temperature Sensor): Measures air pressure and temperature, for example, downstream of the turbocharger.
- BAP (**Barometric Absolute Pressure** Sensor): Measures barometric air pressure.
- BPS (**Brake Pressure** Sensor): Measures air pressure in brake servo systems.



2.7.3 Mass airflow Sensor

A growing focus on reducing CO₂ emissions means that mass airflow sensors are becoming increasingly important in ensuring the optimum air fuel ratio. Mass airflow sensors are positioned directly after the air filter in the intake manifold and supply information on temperature, humidity, and intake air volume.

Despite their highly compact construction they feature precision technology to capture information which - together with other engine data - enables optimum engine management.

This data includes:

- Intake air temperature.
- Intake air humidity.
- Intake air volume.

In gasoline engines, mass airflow measurement is used in conjunction with other sensor readings to regulate the supply of fuel to the engine.

In diesel engines, mass airflow sensors are used to regulate the exhaust gas recirculation rate and calculate the maximum injection quantity.

VDO mass airflow sensors are exceptionally reliable and highly capable of withstanding environmental factors. Their dynamic measurement ability makes an important contribution to reducing vehicle emissions.



Mass airflow senso



2.7.4 Knock Sensor

Modern engines which allow high compression ratios have a distinct disadvantage: their design leads to increased knocking, which can damage the engine. Knock sensors reliably measure the vibration of the engine block that is characteristic of engine knocking. This allows the firing angle and other parameters to be set such that the engine continues to function correctly close to the knock threshold.

This not only protects the engine but also reduces fuel consumption. To ensure maximum precision, VDO knock sensors deploy groundbreaking bandwidth technology.



Knock sensor

2.7.5 Crankshaft Position Sensor

The crankshaft position sensor supplies information on the crankshaft's current position, which the engine management system can then use to calculate rpm. These values make it possible to determine the most economical fuel injection and ignition timing for a vehicle.



Crankshaft Position Sensor

2.7.6 Camshaft Position Sensor

The camshaft position sensor is located in the cylinder head and reads the camshaft sprocket to determine the position of the camshaft. This information is required for functions such as initiating injection on sequential injection engines, the trigger signal for the magnet valve on pump valve injection systems and for cylinder-specific knock control.



Camshaft Position Sensor



2.7.7 High Temperature Sensor (HTS)

The high temperature sensor also performs a key role in the exhaust gas after-treatment process. It delivers impressive long-term stability and provides high accuracy temperature measurements with good linearity. The heat-resistant temperature probe has many applications in innovative systems, including:

- Measurement of exhaust gas temperature for optimization of the combustion process.
- Measurement of exhaust gas temperature for protection of various components.
- Control and monitoring of diesel particulate filter systems.

The measurement range extends up to 950 °C. Thanks to its ability to generate a reliable measurement signal under such harsh conditions, this sensor makes it possible to deliver a perfectly controlled fuel supply for combustion in the diesel particulate filter.

Product benefits:

- High precision.
- Minimal signal aging across the entire life cycle.
- Compact construction allows optional fitment.
- Low thermal inertia ensures rapid response characteristics.



High Temperature Sensor

Technical Specification:	
Response time:	7s @10 m/s (4s @20 m/s)
Sensing temperature:	-40 °C to 950 °C
Working temp. electronics:	-40 °C to 140 °C
Cable temperature capability:	250 °C
Accuracy:	-40 °C to 50 °C ± 10 °C over lifetime 200 °C to 650 °C ± 5 °C over lifetime > 850 °C ± 10 °C over lifetime
Option Supply Voltage (Vs):	24 V or 12 V
Connector:	Tyco HDSCS 4PIN 2.8 connector PN 1-1418390-1 code A
Output:	CAN SAE J1939

* Only available for series production applications on request



2.8 Differential pressure sensor (2-port) for particulate filter

The VDO 2-port pressure sensor for diesel particulate filters provides outstanding differential pressure measurement. This sensor is extremely precise and highly reliable under even the most demanding conditions, thanks to back-side sensing.

Using the differential pressure measured between the filter outlet (P1) and the filter intake (P2), the VDO pressure sensor is able to determine with a high degree of precision the actual exhaust gas flow through the diesel particulate filter and therefore the level of clogging in the filter. The sensor generates an analogue output voltage proportional to the differential pressure, which is used as input by the electronic control unit (ECU). If this voltage exceeds a predefined value stored in the ECU, the control unit initiates a regeneration process to burn off the residue in the particulate filter. This process restores gas flow to the original level, thereby allowing optimal performance to be achieved.

Product benefits:

- Direct pressure measurement.
- Suitable for system-internal and emissions diagnostics.
- Wide measurement range.
- High accuracy and thermal stability.
- Excellent dynamic response.
- Complies with the strictest EMC requirements.
- Resistant to even highly aggressive media.



Differential pressure sensor

Dimensions [mm]

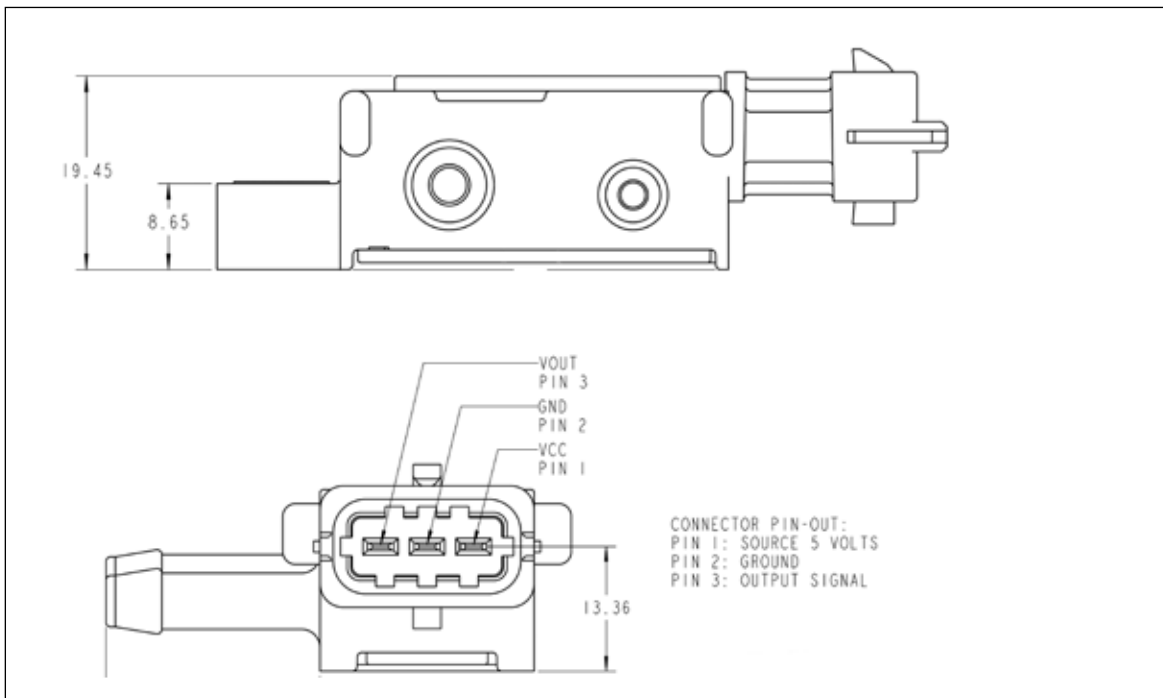
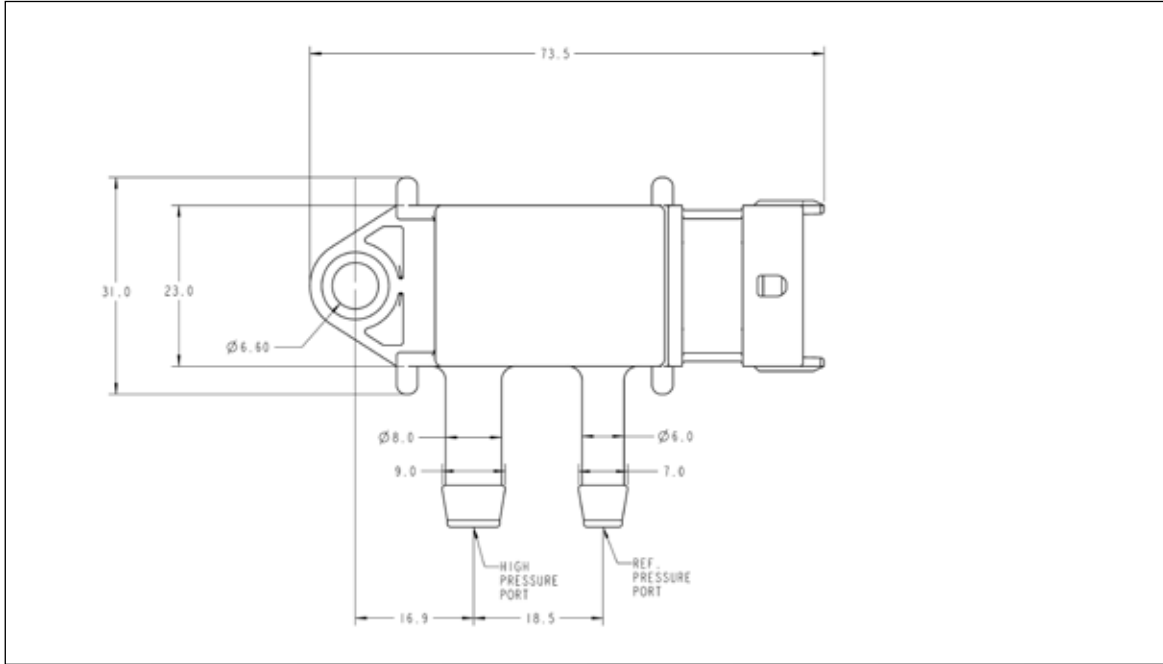

Part number: A2C5951546

Technical Data

Pressure Range:	0 to 35 kPa (Delta)
Temperature Range:	-40 to +125 °C
Supply Voltage (Vs):	5.0 ± 0.25 VDC

P2	Taken upstream of the particle filter	0 kPa < P2 < 80 kPa ¹
P1	Taken downstream of the particle filter	0 kPa < P1 < 40 kPa ¹
dP = P2 - P1	Single analogue output of the differential pressure	0 kPa < dP < 35 kPa

¹ (relative to atmospheric pressure)



2.9 Inertial Sensor

VDO is the world's first manufacturer to combine all the major inertial sensors required in a vehicle in a single unit. Using silicon-based sensors, we've eliminated unwanted frequencies and signal cross-talk while improving resistance to vehicle vibration and extremes in ambient temperature. The resulting inertial sensor is ideally equipped for the exacting demands of specialist vehicle applications.

Performance and safety - sensors for specialist vehicles

Sensors are the eyes and ears of every vehicle. They register every movement, no matter how small, while predicting and preventing hazardous situations long before they occur.

Millions of such sensors are already in use, an integral part of today's intelligent safety systems. The role of inertial sensors is to provide real-time information on rotation rates and acceleration. Those manufactured by VDO are specifically designed for specialist vehicle applications. Having spent many years developing sensors for passenger and commercial vehicles, VDO has the expertise required to make high-precision sensors offering exceptional reliability in the most extreme operating environments. In fact, all the qualities your specialist vehicles require for optimum performance and safety.

Automated processes - maximum safety

Adapted to the unique requirements of specialist vehicles, the VDO inertial sensor offers many important benefits. Key among these is safety. By actively avoiding hazardous situations, the VDO inertial sensor protects man and machine while also ensuring smooth and trouble-free operation. In addition, the sensor enables greater automation of your working processes, thereby increasing the efficiency and productivity of your vehicles.

Precision, intelligence, reliability - also off road

The VDO inertial sensor provides a continuous supply of all key motion-related data to the rest of the vehicle electronics. The sensor measures the rate of rotation around the vertical axis as well as acceleration on all three axes, i.e. the pitch, roll and yaw acceleration of the vehicle. Data is provided to the relevant control units using the CAN SAE J1939 vehicle bus standards.

When working in hazardous situations, e.g. on steep inclines, the sensor information enables greater control and therefore increases safety. The sensor predicts hazards well in advance, enabling the relevant control systems to respond accordingly, e.g. by reducing vehicle speed or signalling a warning to the driver.

Dimensions [mm]

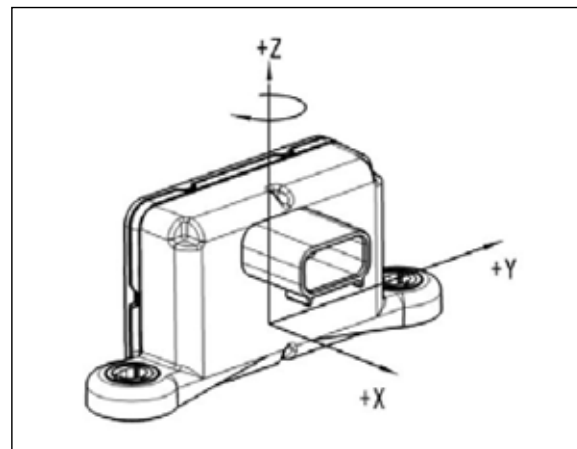
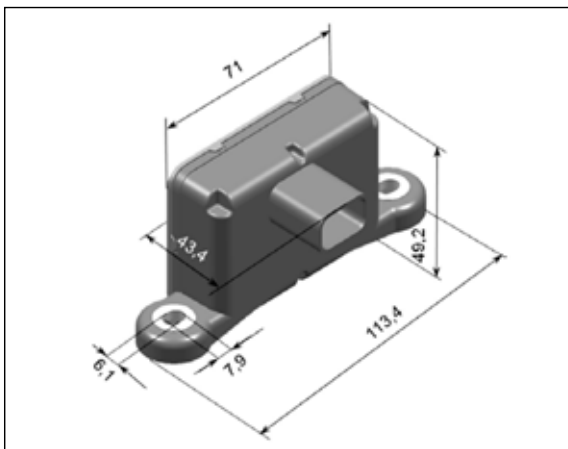

Part number: A2C59514837

Possible applications

- Roll angle calculation.
- Traction control, motion control.
- Passenger recognition.
- Inclination detection.
- Inertial navigation System.
- Rollover protection.
- Maintenance support functions.
- Center of gravity stabilization.
- Chassis control.
- Curve tracking light.

Key Features

- Measurement directions in x-, y-, and z-axis.
- Measurement of angular rate (z-axis).
- Measurement of lateral, longitudinal and vertical acceleration.
- Distribution of measurement signals on CAN.
- SAE J1939.
- Lead free.

Technical Specification

Electrical Characteristics				
Parameter	Min.	Typ.	Max.	Unit
Supply voltage	7.2	12	17	V
Supply current			250	mA
Operating temperature	-40		+85	°C
Power on setup time			1.5	s
Signal output refresh rate		10		ms

Performance Characteristics		
Sensor type	Yaw Rate	Acceleration
Measurement range	-100°/s ... + 100°/s	- 50m/s ² ... + 50m/s ²
Measurement direction	z-axis	x/y/z-axis
Resolution	0,25°/s	0,05m/s ²

Mechanical Characteristics

Case material:	Housing	PBT 1GF15
	Cover	PBT GF15
Weight		62g
Protection class:	IP6K7	(open)
	IP6K9	(with mating connector)
Mounting method:	Fixed with M6 screws or nuts with flanges acc. DIN EN 1664-M6-8	
Tightening Torque:	7 Nm to 9 Nm	
Connector type	USCAR 6 Pin connector Molex 47715-6100	

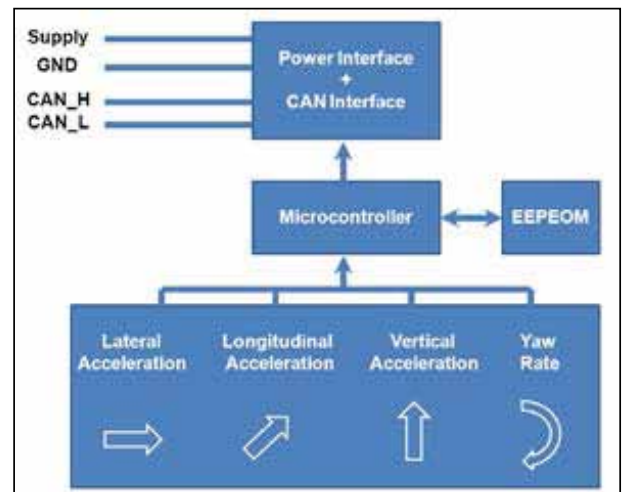

Connector type

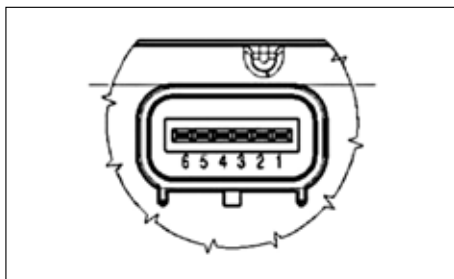

Pin assignment

1	SUPPLY
2	GND
3	CAN H
4	CAN L
5	SEL A
6	SEL B

Additional Information

DIRECTIVE 2000/53/EC

The Sensor Cluster complies with the requirements of the **DIRECTIVE 2000/53/EC** regarding the use of lead and other hazardous substances in electrical components and modules for automotive applications.



2.10 UniNO_x Sensor

Our innovative sensor is helping to meet global demand for increased performance in the face of current and future emissions regulations. UniNO_x sensor technology represents a welcome aid to automotive manufacturers confronted with ever stricter emissions legislation and the simultaneous need to reduce fuel consumption. This sensor is the product of collaborative development between Continental and NGK Insulators, which leveraged the specific expertise of the two companies in the fields of electronics (Continental) and sensor technology (NGK).

Concept

The UniNO_x sensor comprises a zirconia multi-layer ceramic sensing element in a metal housing, connected to an ECU by a 600 mm long cable.

Like in a linear wideband lambda sensor, electrochemical pumps are used to establish the oxygen concentration in the sensing element. NO_x concentration in the exhaust gas is proportional to the pump current in the sensor element.

Based on the measured physical values, the ECU calculates three output signals (NO_x, binary λ , linear λ). These signals are then transmitted to the engine ECU over the CAN bus.

Benefits

- Modular, stand-alone NO_x sensor
 - Communicates via standard CAN bus interface.
 - No ties to suppliers of catalytic converters, electronic control units, and engine management systems.
 - Heating element control and driver stages integrated into ECU.
 - Self-diagnostics for short circuit and cable break.
- High-precision, calibrated UniNO_x sensor
 - Outstanding combined skills base in electronics and sensor technology thanks to collaboration between NGK Insulators and Continental.
 - Over 20 years of experience in sensor technology.
 - Designed by experts in sensor calibration and control techniques.
- Experienced in series production
 - Used in gasoline engines since 2001.
 - Used in diesel engines since 2005.

Applications

Manufacturers seeking to comply with existing and forthcoming emissions standards and the associated legislation, such as Euro 5, 6, V, VI, US07 and US10, can rely on the UniNO_x sensor to support them in implementing various types of exhaust treatment system for both gasoline and diesel engines.

Gasoline engines for cars

UniNO_x sensors are used to control the regeneration cycle of NO_x storage catalysts (NSC) in conjunction with lean-burn engines (GDI/FSI/HPDI).

Diesel engines

- Cars and vans
 - Control of DEF metering in SCR systems.
 - Control of NSC regeneration cycle.
 - Can be used for OBD with all exhaust gas treatment systems.
- Medium and heavy duty trucks
 - Control of DEF metering in SCR systems.
 - Can be used for OBD with all exhaust gas treatment systems.



General specification

Measurement	ZrO ₂ -based multi-layer sensor with integrated heater and 3 oxygen pumps
Three output signals	NO _x , binary λ , linear λ or O ₂ concentration
Electrical system	12 V or 24 V
Data link	SAE J-1939
Self-diagnostics	Short circuit and cable break
Operating temperature (gas)	100 – 800 °C
Measuring range	NO _x : 0 –1,500 ppm λ : 0.75

GENERATION 2.1

UNINOX 12 VOLTS

UNINOX 24 VOLTS

Dimensions [mm]

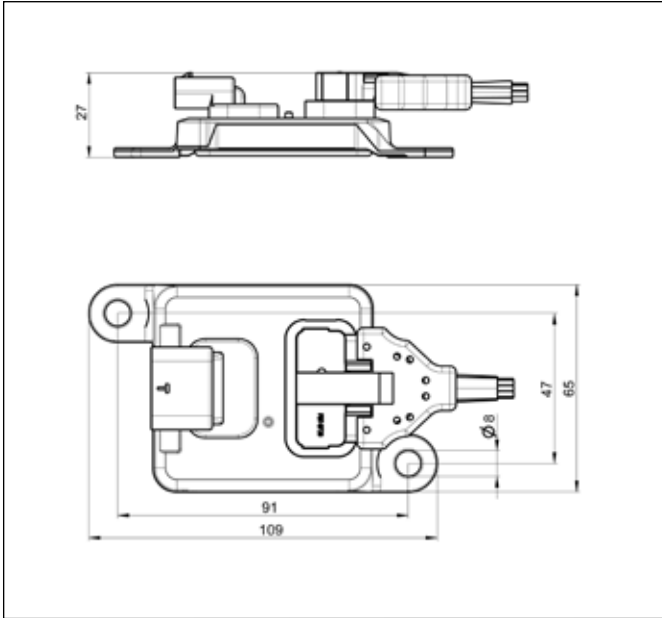

Part Number: 5WK96622

Dimensions [mm]

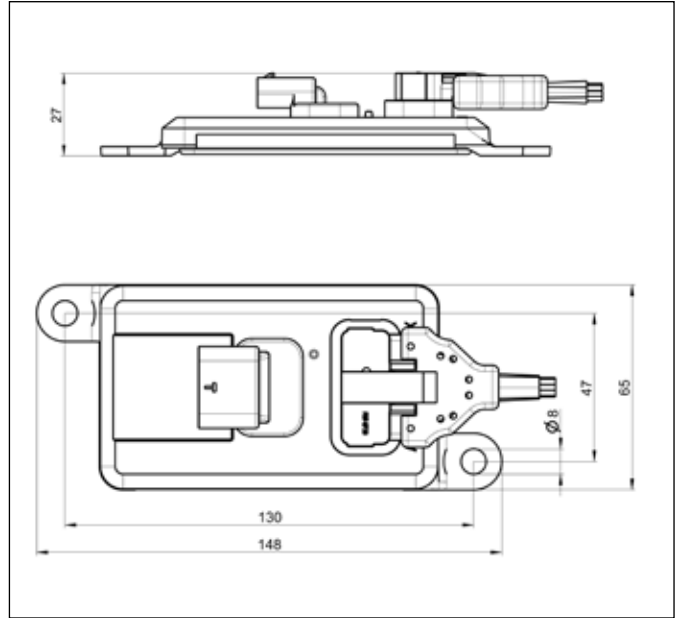

Part Number: A2C53255626

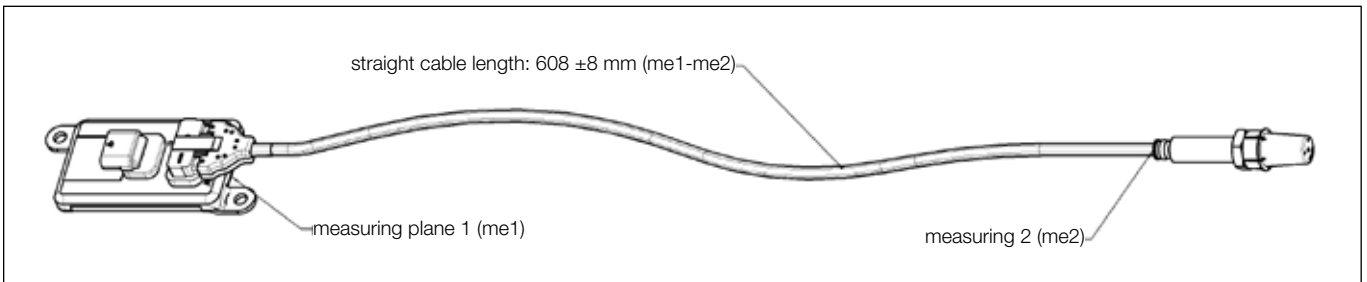
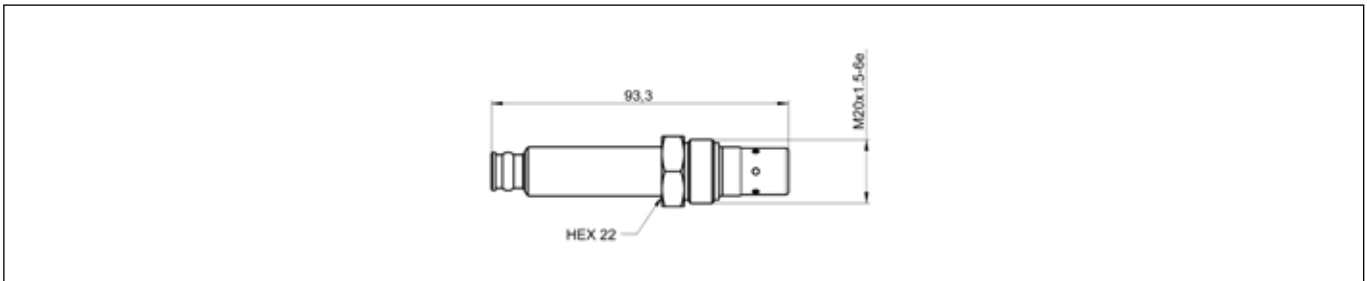

Accessories: Mating-Plug-Kit 12/24 Volts

Part Number	Product	Qty.
A2C59512190	Mating-Plug-Kit 12/24 Volt	10 pc.

GENERATION 2.5

UNINOX 12 VOLTS

UNINOX 24 VOLTS

Dimensions [mm]

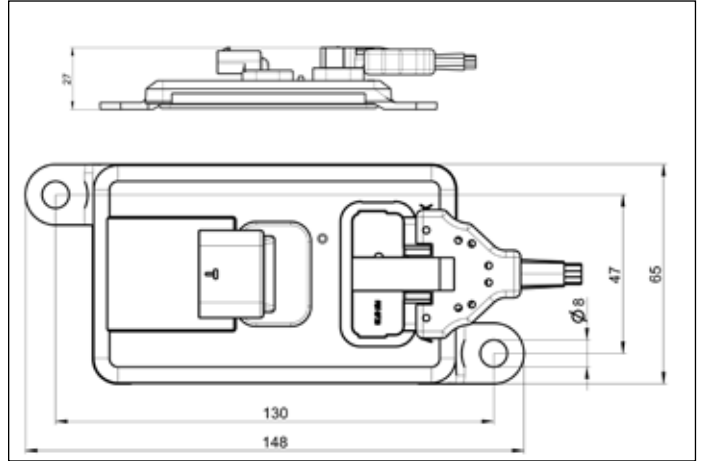
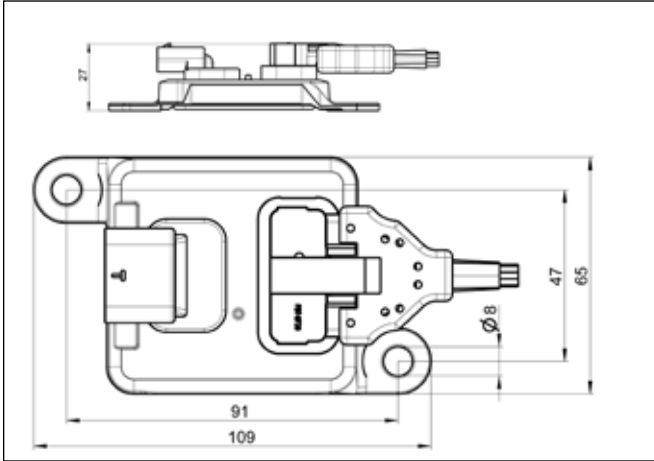

Part Number: 5WK96713

Part Number: 5WK96714

GENERATION 2.5

UNINO_x 12/24 VOLTS

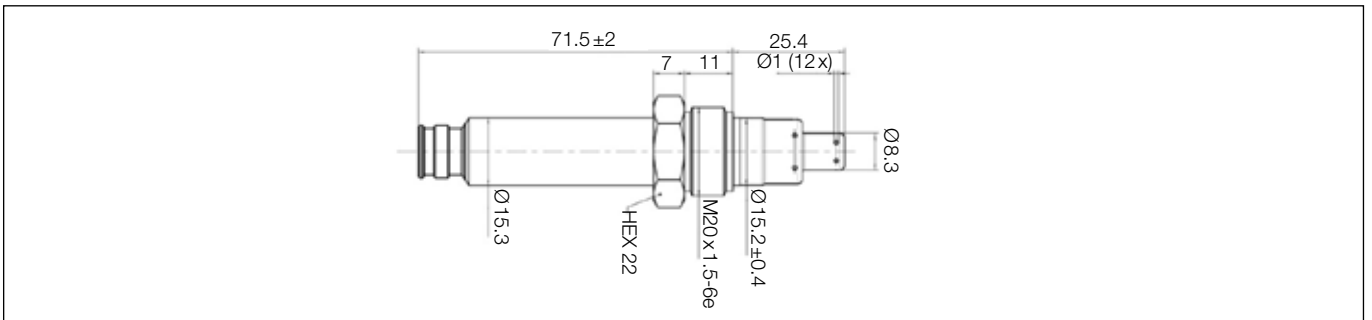
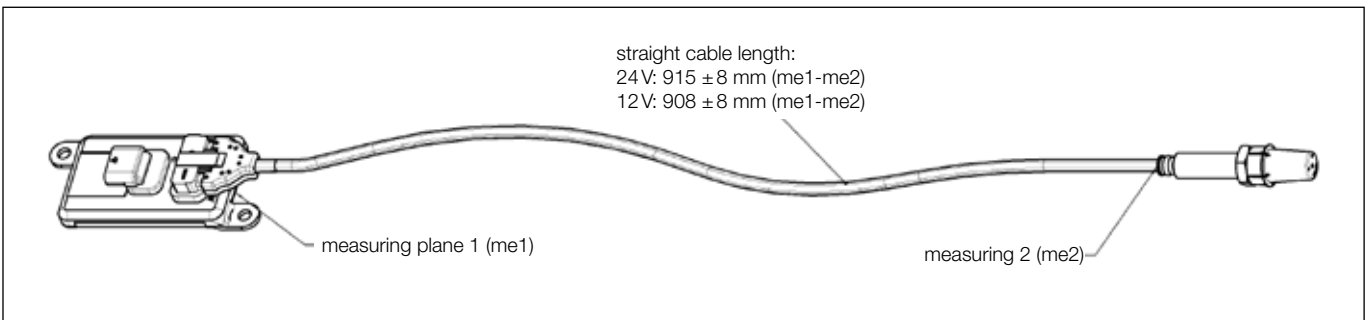

Accessories: Mating-Plug-Kit 12/24 Volts

Part Number	Product	Qty.
A2C59512190	Mating-Plug-Kit 12/24 Volt	10 pc.

The new generation of NO_x Sensor, GEN 2.8, is now available. Compared to the GEN 2.5, the new one provides robustness against corrosion (Plastic cover, AL230 alloy), high temperature stability and improved watersplash and poisoning resistance as well as aging behavior.

GENERATION 2.8

UniNO_x 12 Volts

Dimensions [mm]

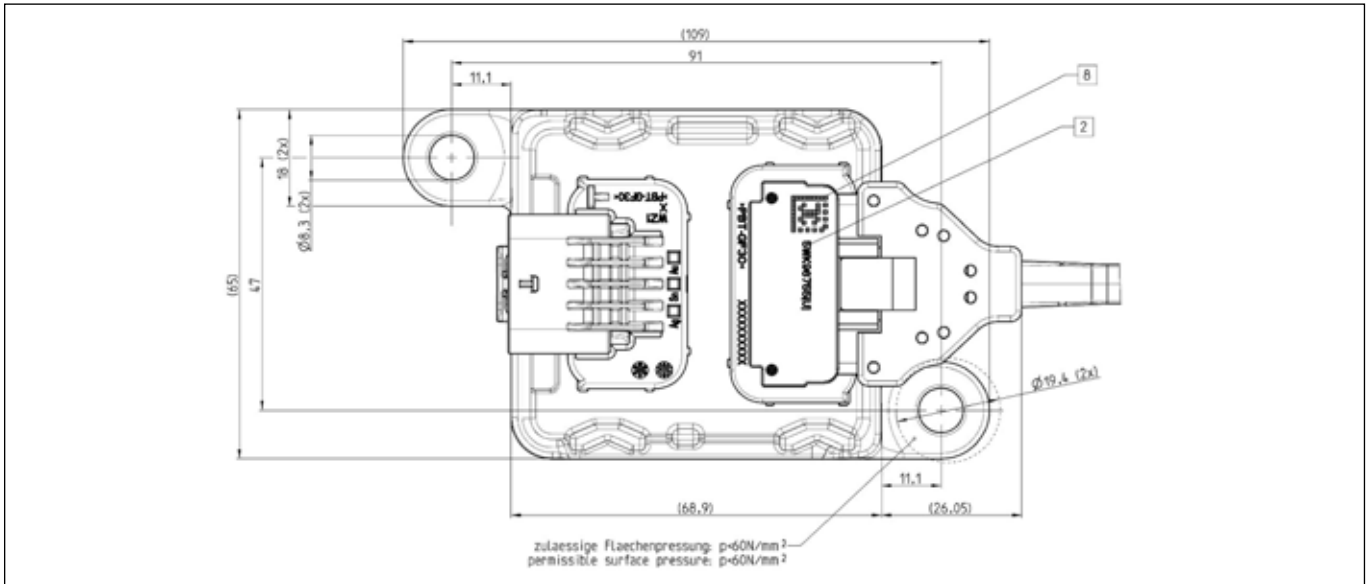

Part Number: 5WK96755

UniNO_x 24 Volts

Dimensions [mm]

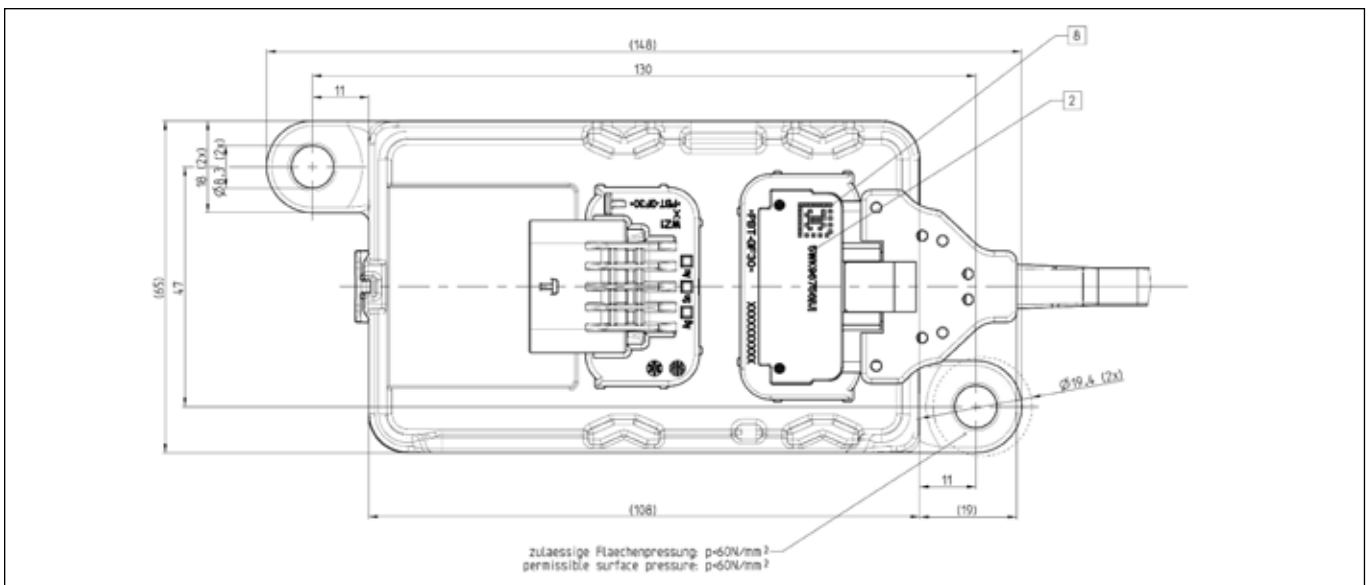

Part Number: 5WK96756



3. Fuel and Water Management Systems

Fuel level measurement for commercial and special vehicles

Little deviations can cause a serious full stop - that is certainly the challenge within fuel level systems. In order to support commercial and special vehicles effectively and efficiently, it is essential to provide reliable information about accurate fuel level at each time.

Innovative solutions

Our sensor systems are specifically optimized for a wide range of applications and the often extremely harsh operating conditions encountered. We have been active in this field for over 30 years and along our sensor innovations, like the MAGnetic Passive Position Sensor (MAPPS), we have been extremely successful in increasing the reliability of fuel level measurement systems, even those used with aggressive fuels.

For tanks of all shapes and sizes

Based on our huge range of different designs and measuring principles, we are able to offer solutions for all kind of tank geometries, flange mounting holes (e.g., EU bayonet flange), and fuel requirements. Thanks to the modular nature of the systems, we are also able to support customers who require only small product batches. For example, we can supply lever-arm senders in custom lengths with batch sizes as small as 2,000 units per year.

Scalable integration

Our extensive range of sender solutions includes classic designs, such as tubular and lever-arm senders, and includes sensors based on thick-film network technology (DSN) and contactless and low-wear sensors. Depending on the requirements of the tank or vehicle manufacturer,

we can provide anything from simple, and robust senders to complex solutions including fuel supply connections (feed and return lines for fuel injection system, auxiliary heating system) and tank ventilation, all integrated in the flange. All systems are built for long service life, regardless of the selected operating principle and design, and withstands many years of proven use in series production applications.

Thick-film network technology (DSN)

Thick-film network technology (DSN) has become an established standard for modern fuel level sensors due to its reliability of measurement and the option of adapting the resistance characteristic curve for asymmetric tank geometries. The numbers stand for themselves - just in 2008, we shipped roughly 30 million units.

We offer several different models of lever-arm senders using DSN technology, all of which are designed to specific standards along the required environments. The standard model provides a double AgNi20 wiper contact and is specified for one million cycles.

A three-finger system is also available with two sets of three contacts, with units designed for either one million cycles (material: Hera 649) or two million cycles (AuNi5), depending on material composition.

One sender, different tanks

Our range also includes an economical solution to cover a wide range of tank shapes by one sensor. The new ALAS II (Adjustable Lever Arm Sensor, 2nd generation) can be adjusted to measure fuel tanks depths between 100 and 400 mm. Vehicle manufacturers and tank system specialists now have the option of using a single type of sensor to equip a whole range of tanks with different depths. This solution is particularly beneficial for the small volume productions that are characteristic of special vehicles.



Plastic lever-arm sender (DSN technology)



Plastic lever-arm sender (MAPPS technology)



Adjustable ALAS II lever-arm sender



Metal tubular level sender



Stainless Steel Level Sender

Contactless measurement in aggressive fuels

Conventional sensor technologies are well suited to meeting the required service life in gasoline and diesel applications, but this is not necessarily the case for new fuels, such as rapeseed methyl ester (RME, bio-diesel). Aggressive components in RME have been found to accelerate wear of contact surfaces in conventional thick-film sensors, even where high-quality contact materials are used. The most reliable way to ensure continued, trouble-free level measurement under these changed conditions is contactless measurement.

Our MAPPS product is able to meet the demands of this type of environment. Thanks to the operating principle employed, these sensors are capable of over ten million cycles. With this patented technology, the actual sensing element is contained in a hermetically sealed housing and never comes into contact with the fuel. Measurements are obtained using a lever-arm sender, which moves a small magnet in an arc across the outside of the sensor housing. The magnetic force actuates 52 individual metal reeds, causing them to touch a contact strip inside the sensor, which in turn creates a variable electrical resistance as the measurement output.



The hermetically sealed MAPPS element is a mere 4 cm long

MAPPS explained: The magnet on the lever arm attracts flexible contact reeds to a contact strip, thereby creating a characteristic resistance signal.



3.1 Fuel and Water Level Senders, Tubular Type

3.1.1 Tubular Fuel Level Sender, Metal,
Standard

3.1.2 Tubular Fuel and Water Level Sender,
Stainless Steel

3.1.3 Tubular Fuel Level Sender, Metal,
Robust

3.1.4 Tubular Fuel Level Sender, Plastic

3.1.1 Tubular Fuel Level Sender, Metal, Standard

FLANGE BOLT HOLE CIRCLE Ø 54 MM

Dimensions [mm]

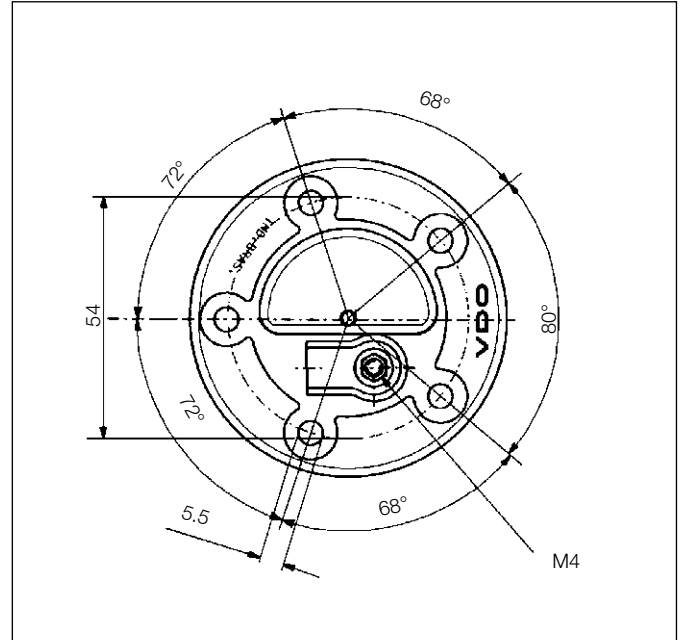
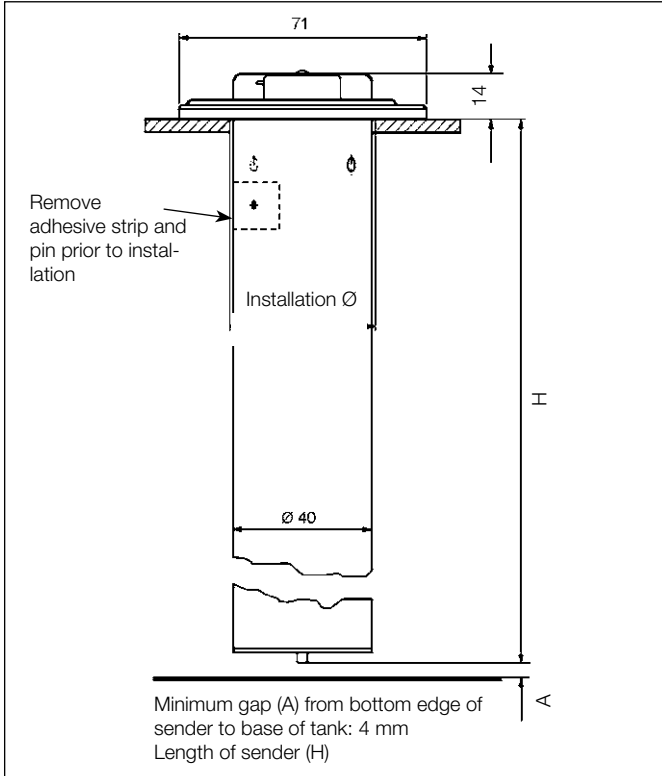

The electrical connection can be configured as follows using the two blade connectors (6.3 x 0.8 mm) supplied:

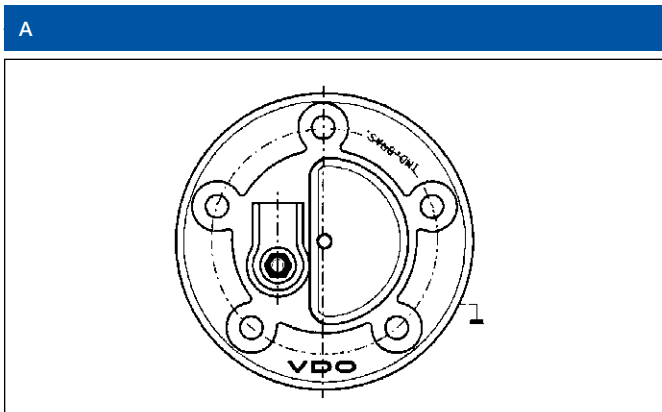

M4 FOR SIGNAL OUTPUT, NO GROUND CONNECTION

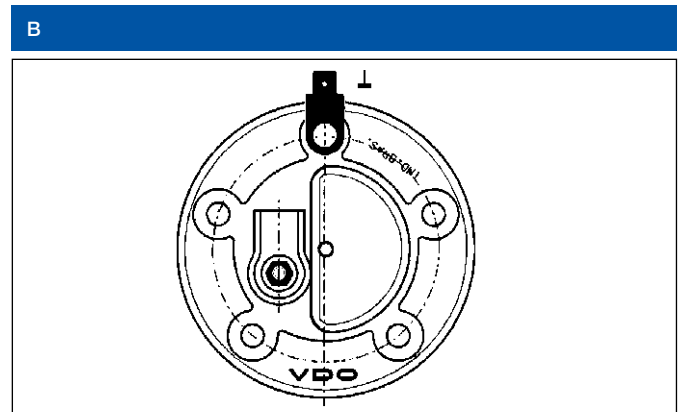

M4 FOR SIGNAL OUTPUT, BLADE CONNECTOR FOR GROUND

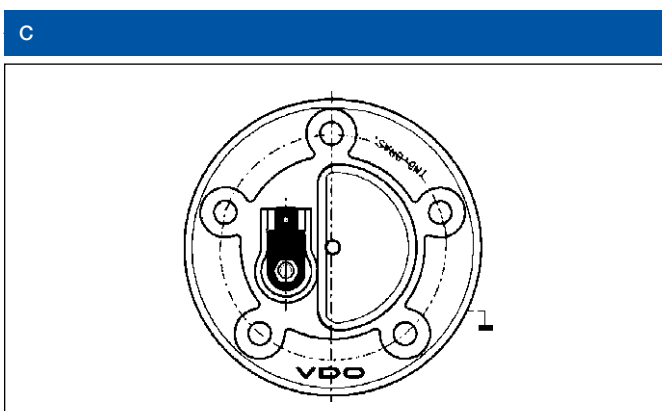

Blade connector for signal output, no ground connection

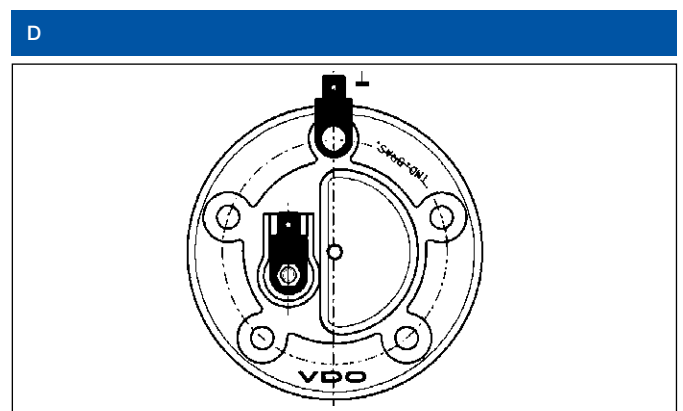

Blade connector for signal output, blade connector for ground

Packaging	Part Number	H [mm]	Support spring	Electrical connection**	Ground connection
40	224-011-000-150X	150	No	1/2	Optional
single	224-011-000-150G	150	No	1/2	Optional
40	224-011-000-160X	160	No	1/2	Optional
single	224-011-000-160G	160	No	1/2	Optional
40	224-011-000-170X	170	No	1/2	Optional
single	224-011-000-170G	170	No	1/2	Optional
40	224-011-000-180X*	180	No	1/2	Optional
single	224-011-000-180G*	180	No	1/2	Optional
40	224-011-000-190X*	190	No	1/2	Optional
single	224-011-000-190G*	190	No	1/2	Optional
40	224-011-000-200X	200	No	1/2	Optional
single	224-011-000-200G	200	No	1/2	Optional
40	224-011-000-210X*	210	No	1/2	Optional
single	224-011-000-210G*	210	No	1/2	Optional
40	224-011-000-220X	220	No	1/2	Optional
single	224-011-000-220G	220	No	1/2	Optional
40	224-011-020-221X	221	No	2	No
single	224-011-020-221G	221	No	2	No
40	224-011-000-230X	230	No	1/2	Optional
single	224-011-000-230G	230	No	1/2	Optional
40	224-011-000-240X	240	No	1/2	Optional
single	224-011-000-240G	240	No	1/2	Optional
40	224-011-000-250X	250	No	1/2	Optional
single	224-011-000-250G	250	No	1/2	Optional
20	224-011-010-251X	251	No	3	No
single	224-011-010-251G	251	No	3	No
40	224-011-000-260X	260	No	1/2	Optional
single	224-011-000-260G	260	No	1/2	Optional
40	224-011-000-270X	270	No	1/2	Optional
single	224-011-000-270G	270	No	1/2	Optional
20	224-011-020-279X	279	No	2	No
single	224-011-020-279G	279	No	2	No
20	224-011-000-280X	280	No	1/2	Optional
single	224-011-000-280G	280	No	1/2	Optional
20	224-011-020-292X	292	No	2	No
single	224-011-020-292G	292	No	2	No
20	224-011-000-300X	300	No	1/2	Optional
single	224-011-000-300G	300	No	1/2	Optional
20	224-011-000-310X	310	No	1/2	Optional
single	224-011-000-310G	310	No	1/2	Optional
20	224-011-010-311X	311	No	3	No
single	224-011-010-311G	311	No	3	No
20	224-011-000-330X*	330	No	1/2	Optional
single	224-011-000-330G*	330	No	1/2	Optional
20	224-011-000-340X	340	No	1/2	Optional
single	224-011-000-340G	340	No	1/2	Optional
20	224-011-010-341X*	341,5	No	3	No
single	224-011-010-341G*	341,5	No	3	No
20	224-011-010-345X*	345	No	3	No
single	224-011-010-345G*	345	No	3	No
20	224-011-000-350X	350	No	1/2	Optional
single	224-011-000-350G	350	No	1/2	Optional
20	224-011-000-360X*	360	No	1/2	Optional
single	224-011-000-360G*	360	No	1/2	Optional

Packaging	Part Number	H [mm]	Support spring	Electrical connection**	Ground connection
20	224-011-000-370X	370	No	1/2	Optional
single	224-011-000-370G	370	No	1/2	Optional
20	224-011-010-372X	372	No	3	No
single	224-011-010-372G	372	No	3	No
20	224-011-020-372X	372	No	2	No
single	224-011-020-372G	372	No	2	No
20	224-011-000-380X	380	No	1/2	Optional
single	224-011-000-380G	380	No	1/2	Optional
20	224-011-000-390X*	390	No	1/2	Optional
single	224-011-000-390G*	390	No	1/2	Optional
20	224-011-000-400X	400	No	1/2	Optional
single	224-011-000-400G	400	No	1/2	Optional
20	224-011-010-404X	404	No	3	No
single	224-011-010-404G	404	No	3	No
20	224-011-010-433X	433	No	3	No
single	224-011-010-433G	433	No	3	No
20	224-011-110-442X	442	Yes	3	No
single	224-011-110-442G	442	Yes	3	No
20	224-011-000-450X	450	No	1/2	Optional
single	224-011-000-450G	450	No	1/2	Optional
20	224-011-010-463X	463	No	3	No
single	224-011-010-463G	463	No	3	No
20	224-011-010-478X	478	No	3	No
single	224-011-010-478G	478	No	3	No
20	224-011-110-498X	498	Yes	3	No
single	224-011-110-498G	498	Yes	3	No
20	224-011-000-500X	500	No	1/2	Optional
single	224-011-000-500G	500	No	1/2	Optional
20	224-011-022-521X*	521	No	2	Yes
single	224-011-022-521G*	521	No	2	Yes
20	224-011-000-550X	550	No	1/2	Optional
single	224-011-000-550G	550	No	1/2	Optional
25	224-011-010-590X	590	No	3	No
single	224-011-010-590G	590	No	3	No
25	224-011-022-590X	590	No	2	Yes
single	224-011-022-590G	590	No	2	Yes
25	224-011-120-596X	596	Yes	2	No
single	224-011-120-596G	596	Yes	2	No
25	224-011-000-600X	600	No	1/2	Optional
single	224-011-000-600G	600	No	1/2	Optional
15	224-011-010-613X*	613,5	No	3	No
single	224-011-010-613G*	613,5	No	3	No
15	224-011-110-634X	634	Yes	3	No
single	224-011-110-634G	634	Yes	3	No
15	224-011-000-650X*	650	No	1/2	Optional
single	224-011-000-650G*	650	No	1/2	Optional
15	224-011-110-650X	650	Yes	3	No
single	224-011-110-650G	650	Yes	3	No
15	224-011-110-664X	664	Yes	3	No
single	224-011-110-664G	664	Yes	3	No
15	224-011-010-691X	691,5	No	3	No
single	224-011-010-691G	691,5	No	3	No

Packaging	Part Number	H [mm]	Support spring	Electrical connection**	Ground connection
15	224-011-000-700X	700	No	1/2	Optional
single	224-011-000-700G	700	No	1/2	Optional
15	224-011-000-750X*	750	No	1/2	Optional
single	224-011-000-750G*	750	No	1/2	Optional
15	224-011-010-786X	786	No	3	No
single	224-011-010-786G	786	No	3	No
15	224-011-000-800X	800	No	1/2	Optional
single	224-011-000-800G	800	No	1/2	Optional
15	224-011-110-810X	810	Yes	3	No
single	224-011-110-810G	810	Yes	3	No

*Supplied on request - limited availability

ACCESSORIES	
Part Number	Description
890-225-012	Seal (Cork Rubber) Ø 66.5 x 4.5 mm
2-250-234	Seal (Cork) Ø 66.5 x 4.5 mm
2-251-243	Seal (Rubber) Ø 65.0 x 2.7 mm
N06-016-230	Seal (Rubber) Ø 65.6 x 3.0 mm
2-250-264-1241	Flange, zinc plated, blue passivated
N05-801-434	Flange kit-bolt on for dip pipe sender

3.1.2 Fuel and Water Level Sensors, Stainless Steel

Tubular sensors, made by stainless steel. They are completely water tight and enable stable and accurate monitoring any type of liquid levels, from water to fuel.

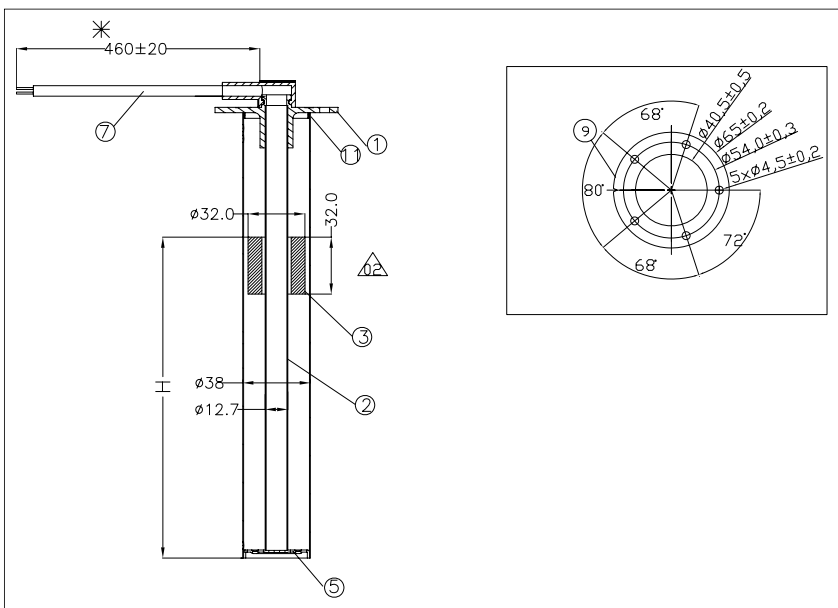

Stainless Steel Level Sender

TECHNICAL DATA	
Available lengths	from 150 to 1000 mm (other lengths on request)
Operating voltage:	6V - 24V
Operating temperature	-30°C a +70°C
Fixing flange:	5 holes Ø 54mm
Material:	Stainless steel AISI316

European standard

Part Number	L	Ω
	[mm]	[Value]
ES-224-011-0150	150	0-180
ES-224-011-0160	160	0-180
ES-224-011-0170	170	0-180
ES-224-011-0180	180	0-180
ES-224-011-0200	200	0-180
ES-224-011-0220	220	0-180
ES-224-011-0230	230	0-180
ES-224-011-0250	250	0-180
ES-224-011-0280	280	0-180
ES-224-011-0300	300	0-180
ES-224-011-0350	350	0-180
ES-224-011-0370	370	0-180
ES-224-011-0400	400	0-180
ES-224-011-0450	450	0-180
ES-224-011-0500	500	0-180
ES-224-011-0550	550	0-180
ES-224-011-0600	600	0-180
ES-224-011-0650	650	0-180
ES-224-011-0700	700	0-180
ES-224-011-0750	750	0-180
ES-224-011-0800	800	0-180
ES-224-011-0850	850	0-180
ES-224-011-0900	900	0-180
ES-224-011-1000	1000	0-180

USA standard

Part Number	L	Ω
	[mm]	[Value]
ES-224-012-0150	150	240-33
ES-224-012-0160	160	240-33
ES-224-012-0170	170	240-33
ES-224-012-0200	200	240-33
ES-224-012-0230	230	240-33
ES-224-012-0250	250	240-33
ES-224-012-0280	280	240-33
ES-224-012-0300	300	240-33
ES-224-012-0330	330	240-33
ES-224-012-0350	350	240-33
ES-224-012-0400	400	240-33
ES-224-012-0430	430	240-33
ES-224-012-0450	450	240-33
ES-224-012-0500	500	240-33
ES-224-012-0550	550	240-33
ES-224-012-0600	600	240-33
ES-224-012-0900	900	240-33
ES-224-012-0980	980	240-33

Note: Other lengths available on request

3.1.3 Tubular Fuel Level Sender, Metal, Robust

FLANGE BOLT HOLE CIRCLE Ø 80 MM

Dimensions [mm]

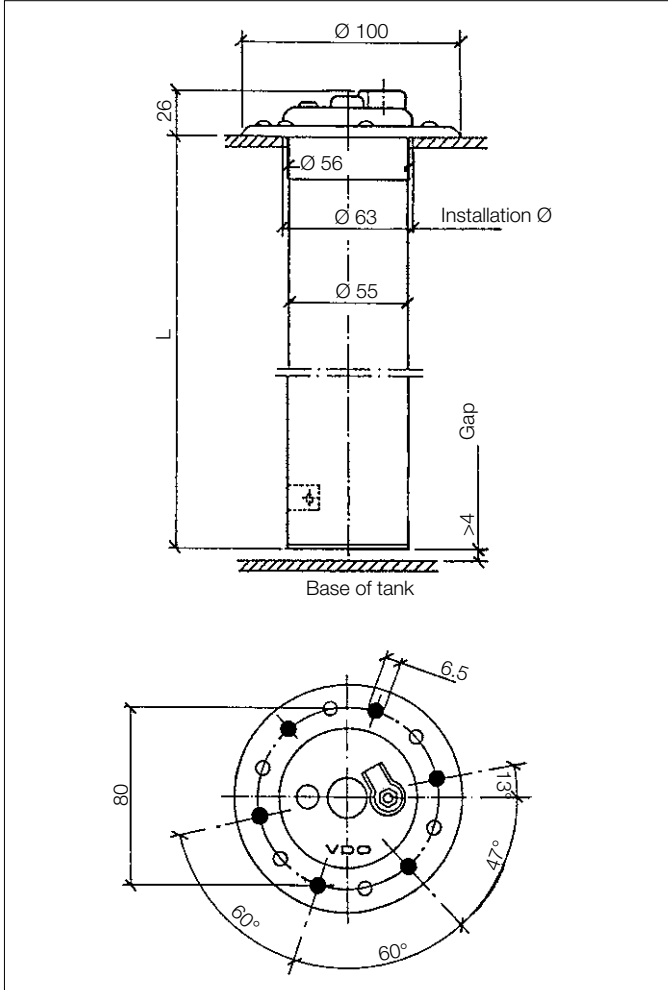

Special features:
(not included as standard)

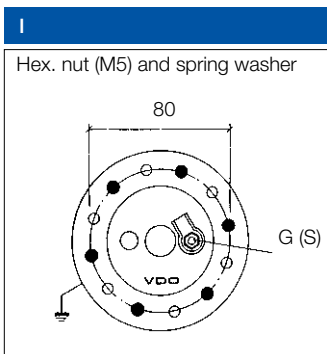
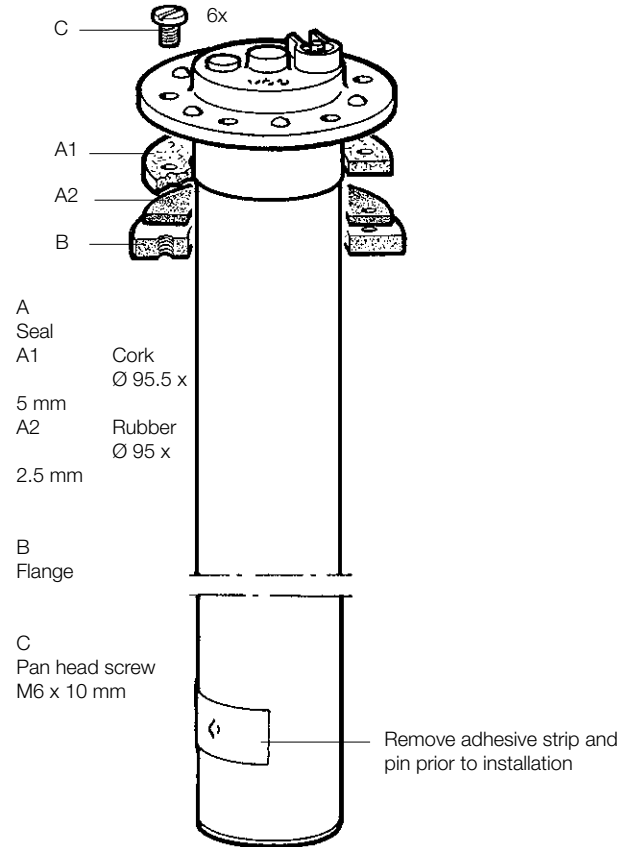

Ground on sender housing (tank)

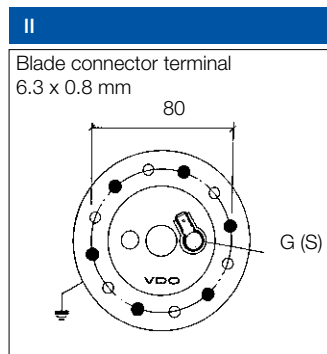

Ground on sender housing (tank)

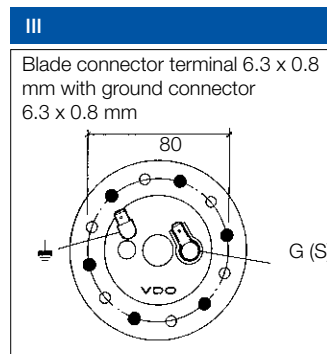

Ground on sender housing (tank)

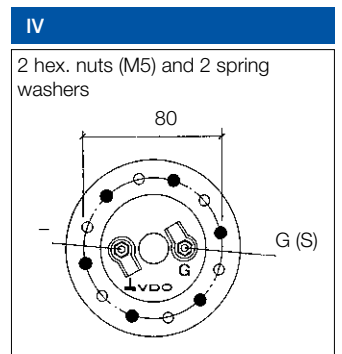

Insulated return

Part Number	Installation depth L	Resistance / float limit stop		Type	Special feature
	[mm]	Top [Ω]	Bottom [Ω]		
X10-224-014-036	500	1.0 \pm 0.4	63.3 \pm 1.4	III	A2
X10-224-009-037	536	0.8 \pm 0.4	67.2 \pm 1.4	I	–
X10-224-009-053	551	0.8 \pm 0.4	69.3 \pm 1.4	I	A1
X10-224-009-039	596	1.3 \pm 0.4	75.0 \pm 1.6	I	A2
X10-224-009-048	641	0.8 \pm 0.4	81.0 \pm 1.8	I	A1
X10-224-014-002	686	0.8 \pm 0.4	86.7 \pm 1.8	III	–
X10-224-009-016	716	0.6 \pm 0.4	69.7 \pm 1.4	I	A2, B
X10-224-009-029	741	0.5 \pm 0.4	65.0 \pm 1.4	I	A2, B, C
X10-224-009-019	781	0.5 \pm 0.4	68.7 \pm 1.4	I	A2
X10-224-021-004	803	0.7 \pm 0.4	71.1 \pm 1.6	IV	A1
X10-224-009-026	831	0.6 \pm 0.4	82.8 \pm 1.8	I	A2, B, C
X10-224-021-006	846	0.7 \pm 0.4	75.0 \pm 1.6	IV	A1
X10-224-014-011	916	0.7 \pm 0.4	81.2 \pm 1.8	II	A2
X10-224-014-023	946	0.7 \pm 0.7	83.9 \pm 2.5	II	A1
X10-224-014-015	996	0.5 \pm 0.4	59.0 \pm 1.2	II	A2
X10-224-009-021	1,045	0.5 \pm 0.4	92.5 \pm 2.0	I	A2, B, C
X10-224-021-005	1,045	0.7 \pm 0.4	92.9 \pm 2.0	IV	A1
X10-224-009-040	1,086	0.4 \pm 0.4	64.0 \pm 1.4	I	A2, B

TECHNICAL DATA

Rated voltage	6–24 V
Operating temperature	-25 °C to +70 °C
Installation from above	

ACCESSORIES

Part Number	Description
2-251-006	Seal (Cork) \varnothing 95.5 x 5.0 mm
2-251-016	Seal (Rubber) \varnothing 95.0 x 2.5 mm
11-591-001-1401	Flange, brass plated

3.1.4 Tubular Fuel Level Sender, Plastic

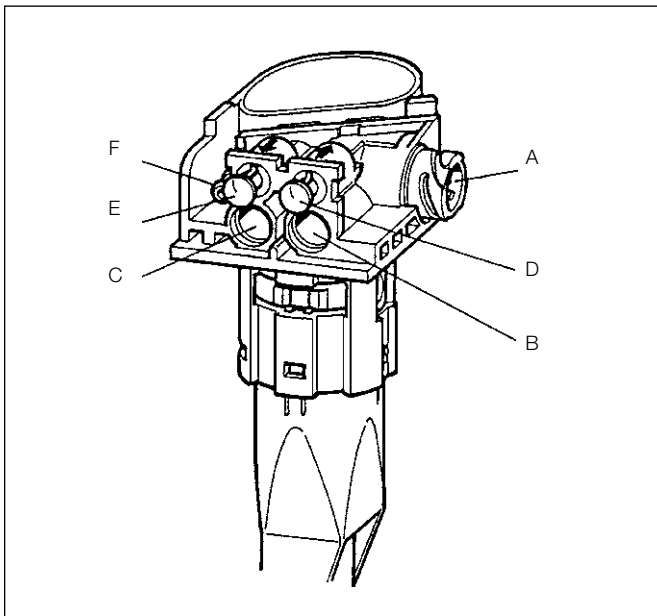

Technical data

Rated voltage	6–24 V (insulated return)	
Resistance	3 Ω (empty) to 180 Ω (full)	
Current	20 mA to 120 mA	
Operating temperature	-30 °C to +70 °C	
Air inlet and outlet valves	Positive pressure up to 200 mbar corresponds to flow rate of less than 25 g/min diesel fuel. Positive pressure greater than 300 mbar corresponds to flow rate of more than 25 g/min diesel fuel. Negative pressure of 10–20 mbar corresponds to flow rate of more than 1.75	
Service life	1 million full/empty cycles in super unleaded fuel	
Vibration test	20 to 50 Hz g ² /Hz 50 to 1,000 Hz dB/oct 8 h / axial direction	PSD = 0.03 PSD = -6
Material	Flange, sender body, float: POM-C Float lever arm: X12CrNi 177k Tube: PA11 or PA12	

Connectors

A	Bayonet connector, DIN 72585 (A1-2.1RG/K1)
B	Outlet
C	Inlet
D	External heater outlet or pressure equalization with another tank
E	External heater inlet
F	Air outlet via valve

Dimensions [mm]

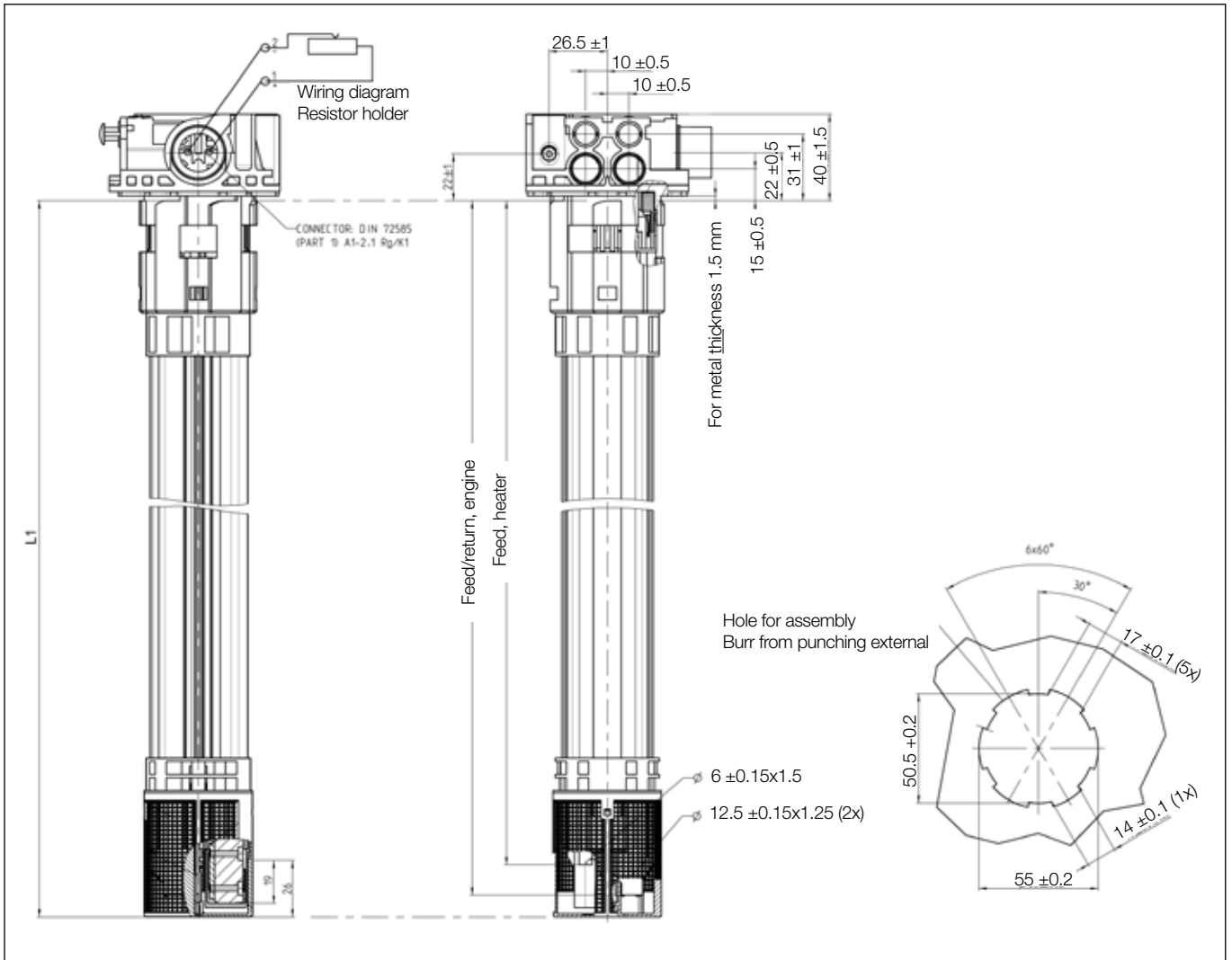

Part Number	Overall length L1	Length to inlet tube, L2	Length to heating tube, L3
	[mm]	[mm]	[mm]
A2C59510128	455 ± 2	$446 \begin{smallmatrix} +2.5 \\ -3.5 \end{smallmatrix}$	$432 \begin{smallmatrix} +2.5 \\ -3.5 \end{smallmatrix}$
A2C59510129	544 ± 2	$535 \begin{smallmatrix} +2.5 \\ -3.5 \end{smallmatrix}$	$519 \begin{smallmatrix} +2.5 \\ -3.5 \end{smallmatrix}$
A2C59510130	672 ± 2	$663 \begin{smallmatrix} +2.5 \\ -3.5 \end{smallmatrix}$	$654 \begin{smallmatrix} +2.5 \\ -3.5 \end{smallmatrix}$

Full: $180 \Omega \pm 3.7 \Omega$, empty: $3 \Omega \pm 1.05 \Omega$

Part Number	Accessories	Units per pack
89-356-017	O-ring (seal)	100
X11-221-001-002	Inlet/outlet connector	20
X11-221-001-003	Locking mechanism for inlet/outlet or external heater	10
X11-221-001-004	External heater connector	20
Standard	Electrical connector for bayonet connector DIN 72585 A1-2.1 SN/K1	



3.2 Fuel Level Senders, Lever-Arm Type

3.2.1 Lever-Arm Fuel Level Sender, Plastic

3.2.2 Adjustable Lever-Arm Fuel Level Sender,
Standard/ALAS I

3.2.3 Adjustable Lever-Arm Fuel Level Sender,
ALAS II

3.2.1 Lever-Arm Fuel Level Sender, Plastic



Technical data	
Rated voltage	6–24 V (insulated return)
Resistance	3 Ω (empty) to 180 Ω (full)
Current	20 mA to 120 mA
Operating temperature	-30 °C to +70 °C
Air inlet and outlet valves	Positive pressure up to 200 mbar corresponds to flow rate of less than 25 g/min diesel fuel. Positive pressure greater than 300 mbar corresponds to flow rate of more than 25 g/min diesel fuel. Negative pressure of 10–20 mbar corresponds to flow rate of more than 1.75 l/h diesel fuel.
Service life	1 million full/empty cycles in diesel fuel
Vibration test	20 to 50 Hz PSD = 0.03 g ² /Hz 50 bis 1,000 Hz PSD = -6 dB/oct 8 h / axial direction
Material	Flange, sender body, float: POM-C Float lever arm: X10CrNi 18-8 Tube: PA11 or PA12

Connectors	
A	Bayonet connector, DIN 72585 (A1-2.1RG/K1)
B	Outlet
C	Inlet
D	External heater outlet or pressure equalization with another tank
E	External heater inlet
F	Air outlet via valve

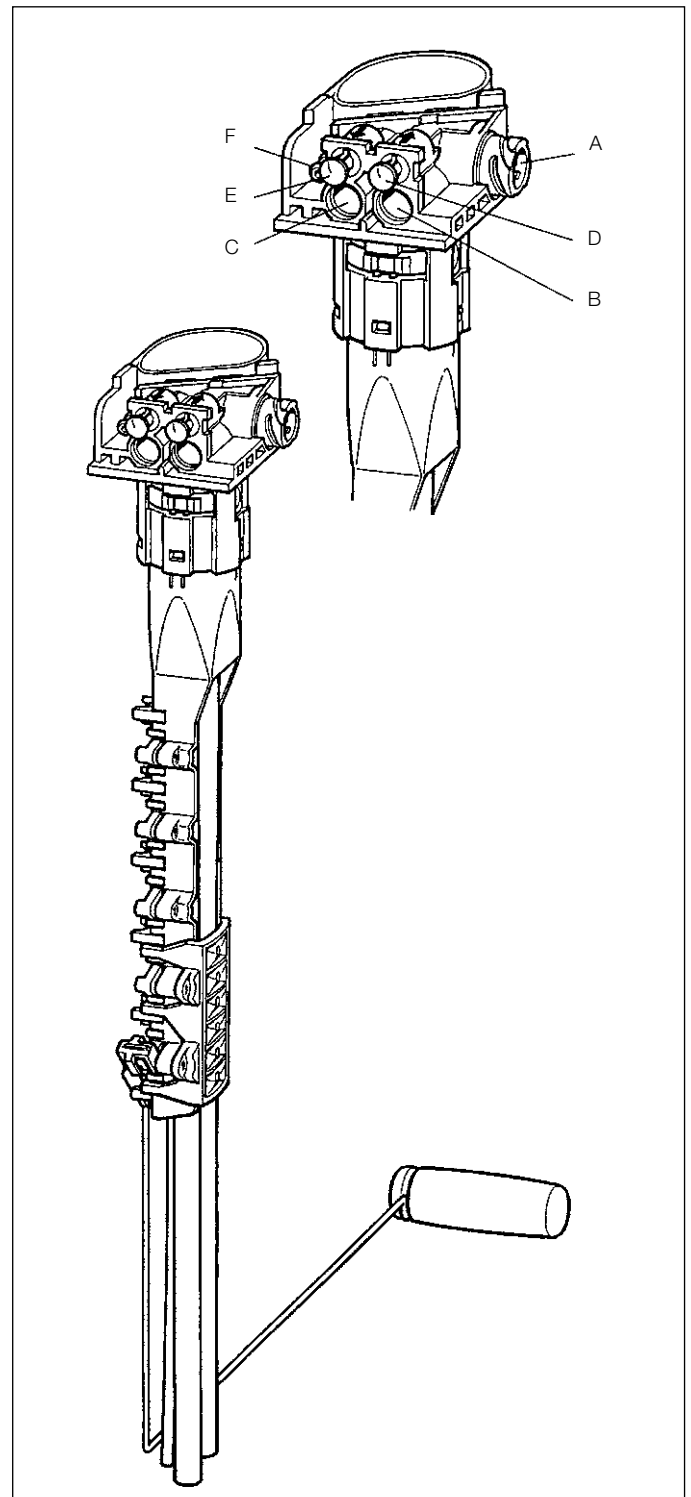

Dimensions [mm]

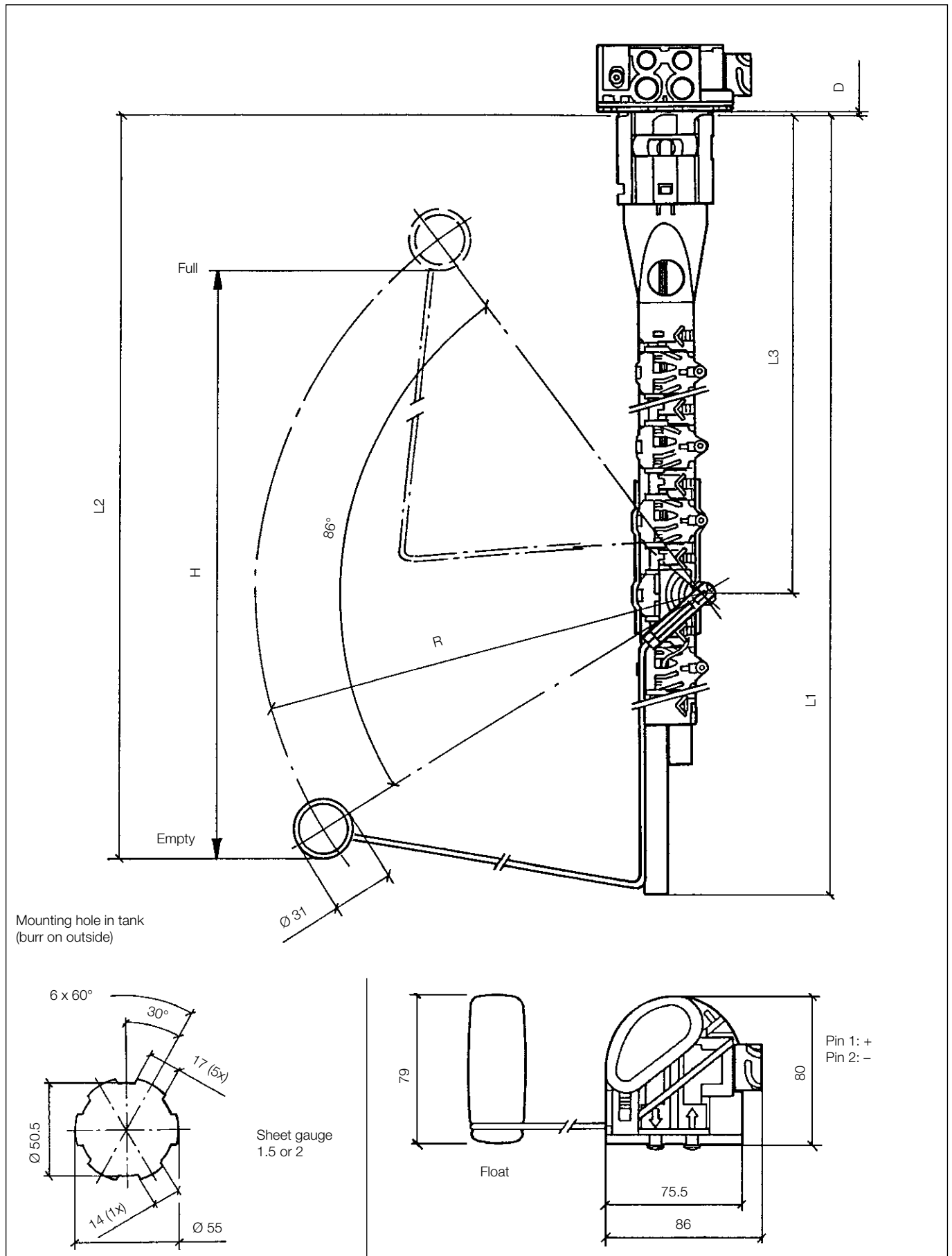

VERSION 1

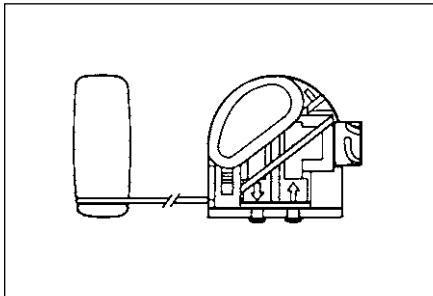

VERSION 2

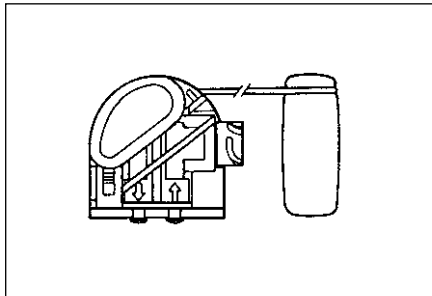

VERSION 3

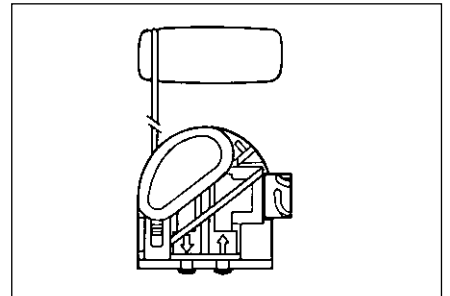

Part Number	Dimensions [mm]						Version
	L1	L2	L3	R	H	D	
	Depth required for installation Length to bottom edge of vacuum tube	Length to bottom edge of float	Length to lever pivot point	Lever arm radius excl. float	Stroke empty-full	Sheet gauge	
221-824-054-049C	405	393	274	238	310	1.5	2
221-824-054-050C	450	402	232	269	363	1.5	1
221-824-054-051C	492	482	190	325	430	1.5	3
221-824-054-056C	535	537	232	374	506	1.5	3
221-824-054-053C	568	485	274	311	423	2.0	1
221-824-054-052C	611	568	316	385	523	2.0	3
221-824-054-054C	670	625	316	418	570	1.5	3
221-824-054-055C	670	670	316	463	630	1.5	3

Part Number	Accessories	Units per pack
89-356-017	O-ring (seal)	100
993-371-016	Fuel-Filter	4
X11-221-001-002	Inlet/outlet connector	20
X11-221-001-003	Locking mechanism for inlet/outlet or external heater	10
X11-221-001-004	External heater connector	20
STANDARD	Electrical connector for bayonet connector DIN 72585 A1-2.1 SN/K1	

3.2.2 Adjustable Lever-Arm Fuel Level Sender, Standard/ALAS I

STANDARD ADJUSTABLE LEVER ARM SENDER WITH ADJUSTABLE FLANGE

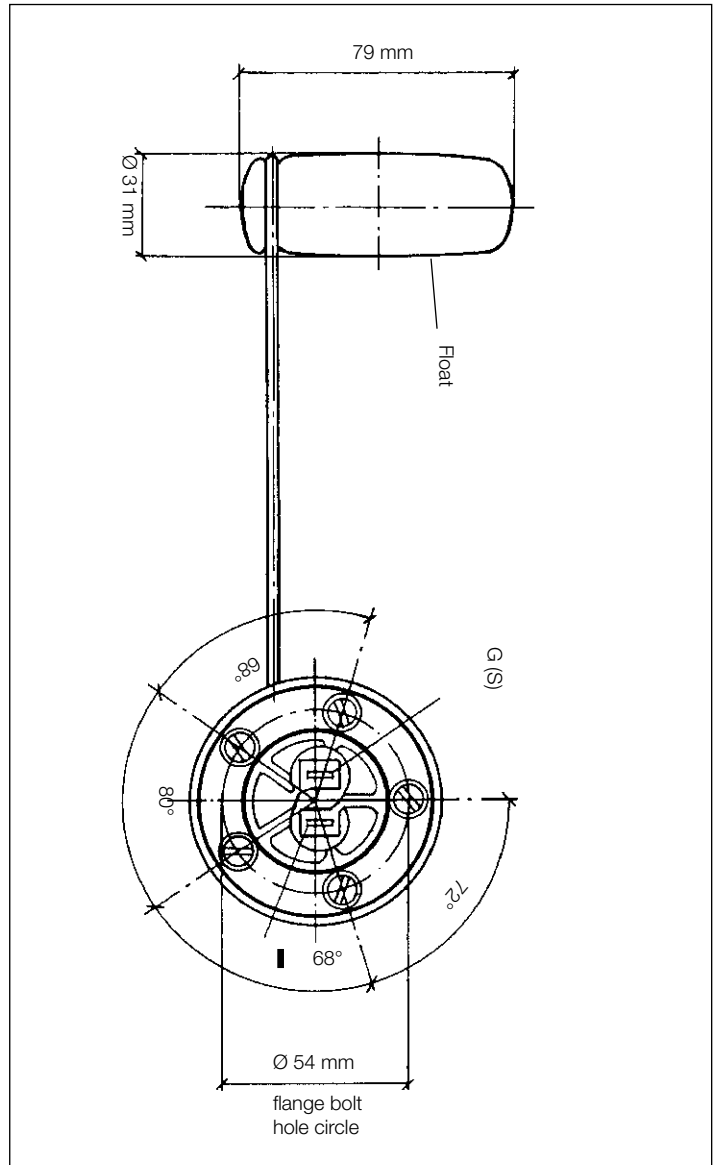
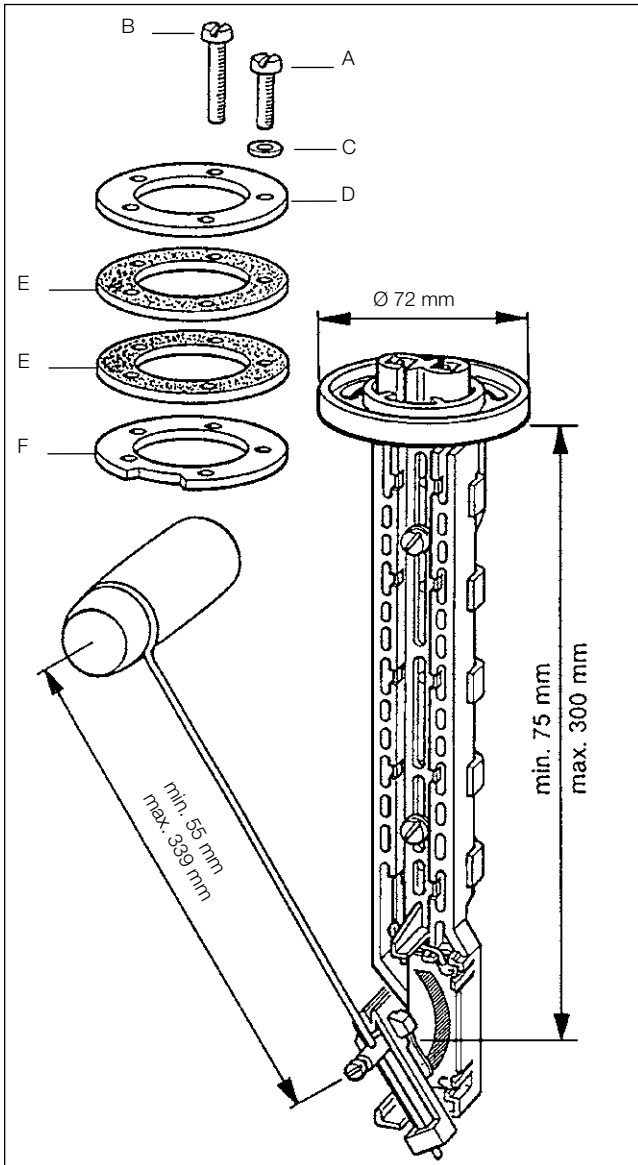

Part Number: 226-801-015-001G

Part Number: 226-801-015-001C (bulk 10 pcs.)

Technical data

Rated voltage	6–24 V (insulated return)		
Resistance	Empty	3 Ω	± 1.5 Ω
	Full	180 Ω	± 12 Ω
Operating temperature	-20 °C to +65 °C		
Blade connector terminal (2-way)	6.3 mm x 0.8 mm		
Tank flange	A	Screw M5 x 15	(4x)
	B	Screw M5 x 30	(1x)
	C	Sealing washer	(5x)
	D	Flange	(1x)
	E	Rubber seal	(2x)
	F	Slotted flange	(1x)
For dual units (identifier "D")	N02-240-106		

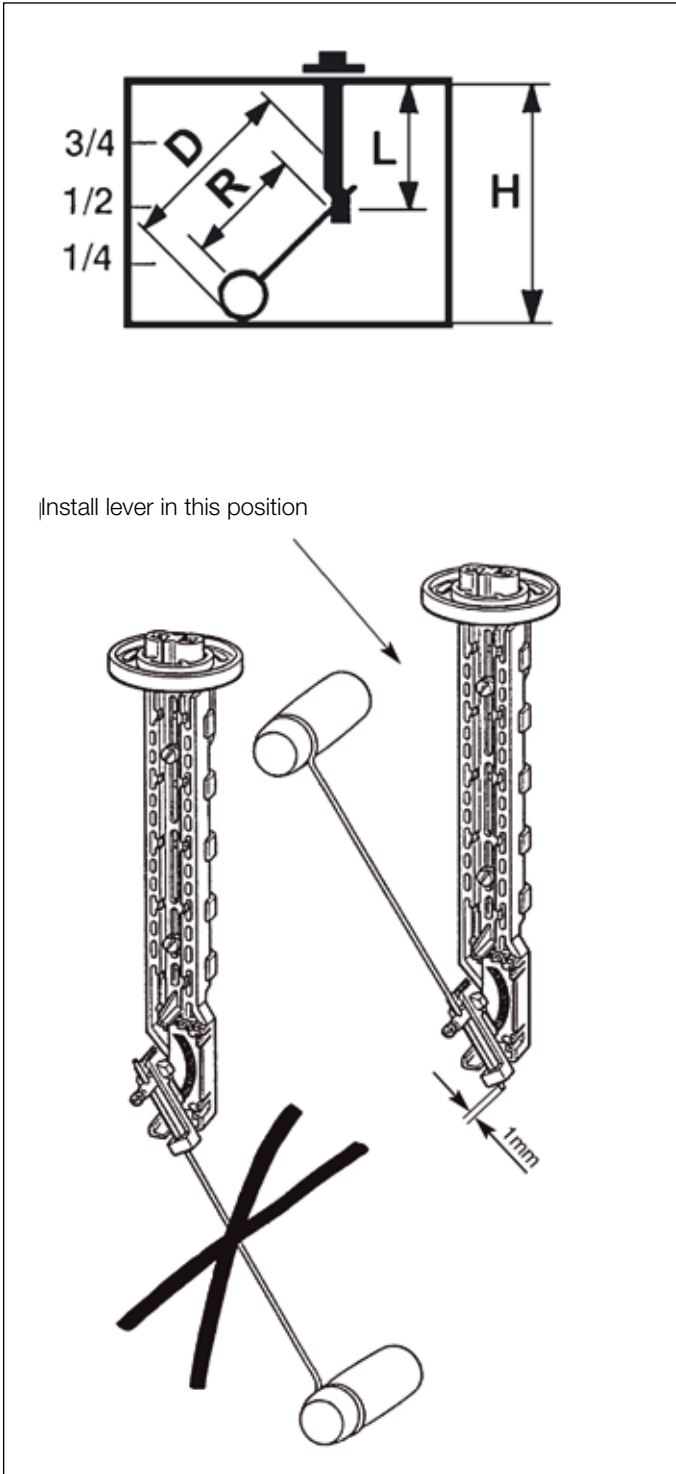

ADJUSTMENT
 Adjust the length (L) of the sender unit and the distance (D) of the lever arm according to the height (H) of the fuel tank.

H	L	R	D
150	75	55	109
155	77.5	58	112
160	80	61	115
165	82.5	64	118
170	85	67	121
175	87.5	70	124
180	90	73	127
185	92.5	76	130
190	95	80	134
195	97.5	83	137
200	100	86	140
205	102.5	89	143
210	105	92	146
215	107.5	95	149
220	110	98	152
225	112.5	101	155
230	115	105	159
235	117.5	108	162
240	120	111	165
245	122.5	114	168
250	125	118	172
255	127.5	121	175
260	130	124	178
265	132.5	127	181
270	135	130	184
275	137.5	133	187
280	140	136	190
285	142.5	139	193
290	145	142	196
295	147.5	145	199
300	150	148	202
305	152.5	152	206
310	155	155	209
315	157.5	158	212
320	160	161	215
325	162.5	164	218
330	165	167	221
335	167.5	170	224
340	170	173	227
345	172.5	177	231
350	175	180	234
355	177.5	183	237
360	180	186	240
365	182.5	189	243
370	185	192	246
375	187.5	195	249

H	L	R	D
380	190	199	253
385	192.5	202	256
390	195	205	259
395	197.5	208	262
400	200	211	265
405	202.5	214	268
410	205	217	271
415	207.5	220	274
420	210	224	278
425	212.5	227	281
430	215	230	284
435	217.5	232	286
440	220	235	289
445	222.5	238	292
450	225	242	296
455	227.5	245	299
460	230	249	303
465	232.5	252	306
470	235	255	309
475	237.5	258	312
480	240	261	315
485	242.5	264	318
490	245	267	321
495	247.5	271	325
500	250	274	328
505	252.5	277	331
510	255	280	334
515	257.5	283	337
520	260	286	340
525	262.5	289	343
530	265	292	346
535	267.5	296	350
540	270	299	353
545	272.5	302	356
550	275	305	359
555	277.5	308	362
560	280	311	365
565	282.5	314	368
570	285	317	371
575	287.5	321	375
580	290	324	378
585	292.5	327	381
590	295	330	384
595	297.5	333	387
600	300	336	390
605	302.5	339	393

A NEW GENERATION OF LEVER-ARM SENDERS

Our new, specially developed lever-arm fuel senders now offer our customers an extremely flexible and robust way of ensuring reliable fuel measurement for various tank depths.

The system is based on a lever arm, which generates a signal corresponding to the current fuel level. The length of the lever arm can be adapted to specific requirements and shortened as needed. This makes it possible to equip various tank depths (145 mm to 400 mm) using just one system - something that is particularly advantageous with shallow tanks.

Two versions of the adjustable lever-arm fuel level sender are available, with and without a warning contact. The integrated warning contact version generates an additional control signal when the fuel level in the tank falls to a pre-defined level, which can be used to trigger an external reserve level indicator, for example. A specialized bearing with many years of proven marine use allows the lever arm to compensate for slopping of fuel in the tank. This reliable, rugged design delivers high accuracy read outs and is now available for a wide range of alternative applications, from small machines through agricultural vehicles to large stationary machines.

ALAS I

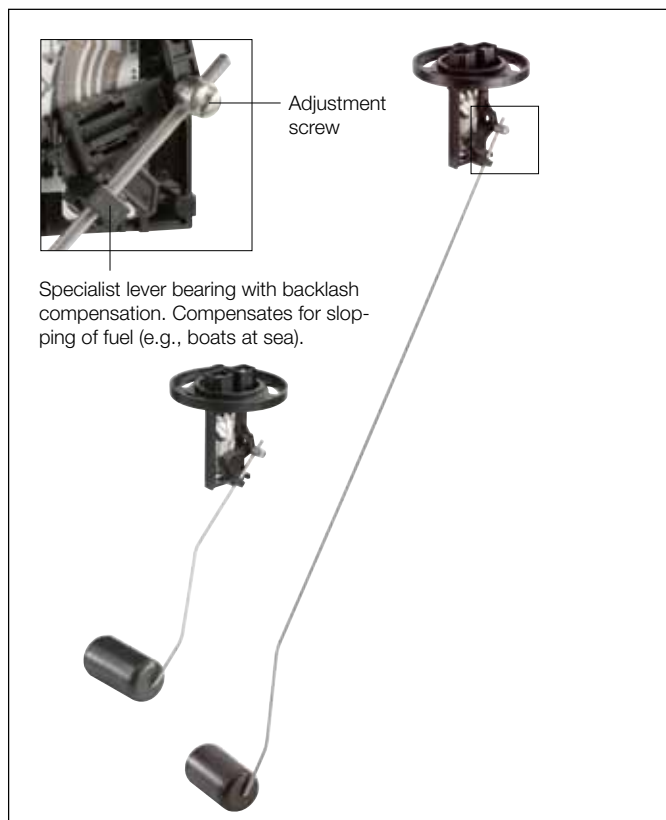

Flexible adjustment for tank depths from 145 to 400 mm.

Wide range of applications

- Small engines and construction machines (mini-excavators, dumpers, compressors, etc.).
- Processing and agricultural machinery.
- Marine applications (sports and leisure boats, jet skis, etc.).
- Two-wheeled vehicles (motorcycles, scooters, etc.).
- Micro cars, quad bikes.
- Stationary machines (mini-excavators, dumpers, compressors, etc.).



Part Number: N05-801-432

Mounting kit

(available separately, not included as standard)

Benefits

- Adjustable lever-arm fuel-level sender.
- Available with and without warning contact.
- Ø 54 mm - standard flange.
- 3 different resistance ranges (DSN thick-film technology) for use with standard gauges (alternative resistance ranges can be defined according to specific customer requirements).
- Straightforward adaptation to different tank depths thanks to easily adjusted lever arm.
- Rugged design.
- Long service life, redundant contact system.
- All metal construction in stainless steel.
- Nitrile rubber float - will not sink if damaged.
- Electrical connections protected by connector housings.
- Elongated holes for flexible installation.
- Lever bearing with backlash compensation guarantees extended service life, continuously compensating for wave action affecting boats, for example.
- Longlife resistive element (1 million "full/empty" cycles with super unleaded fuel).

Dimensions [mm]

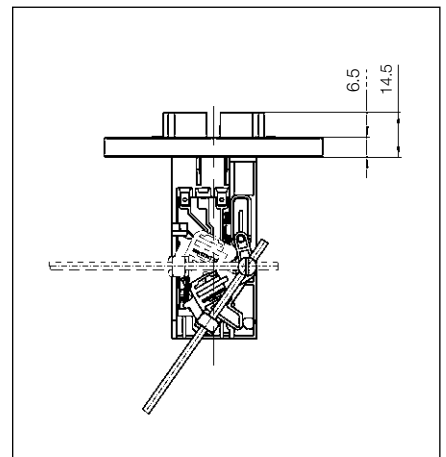
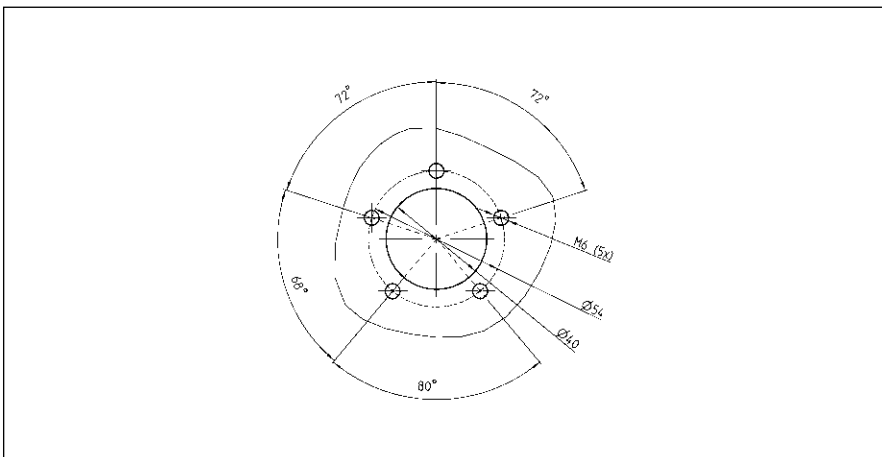
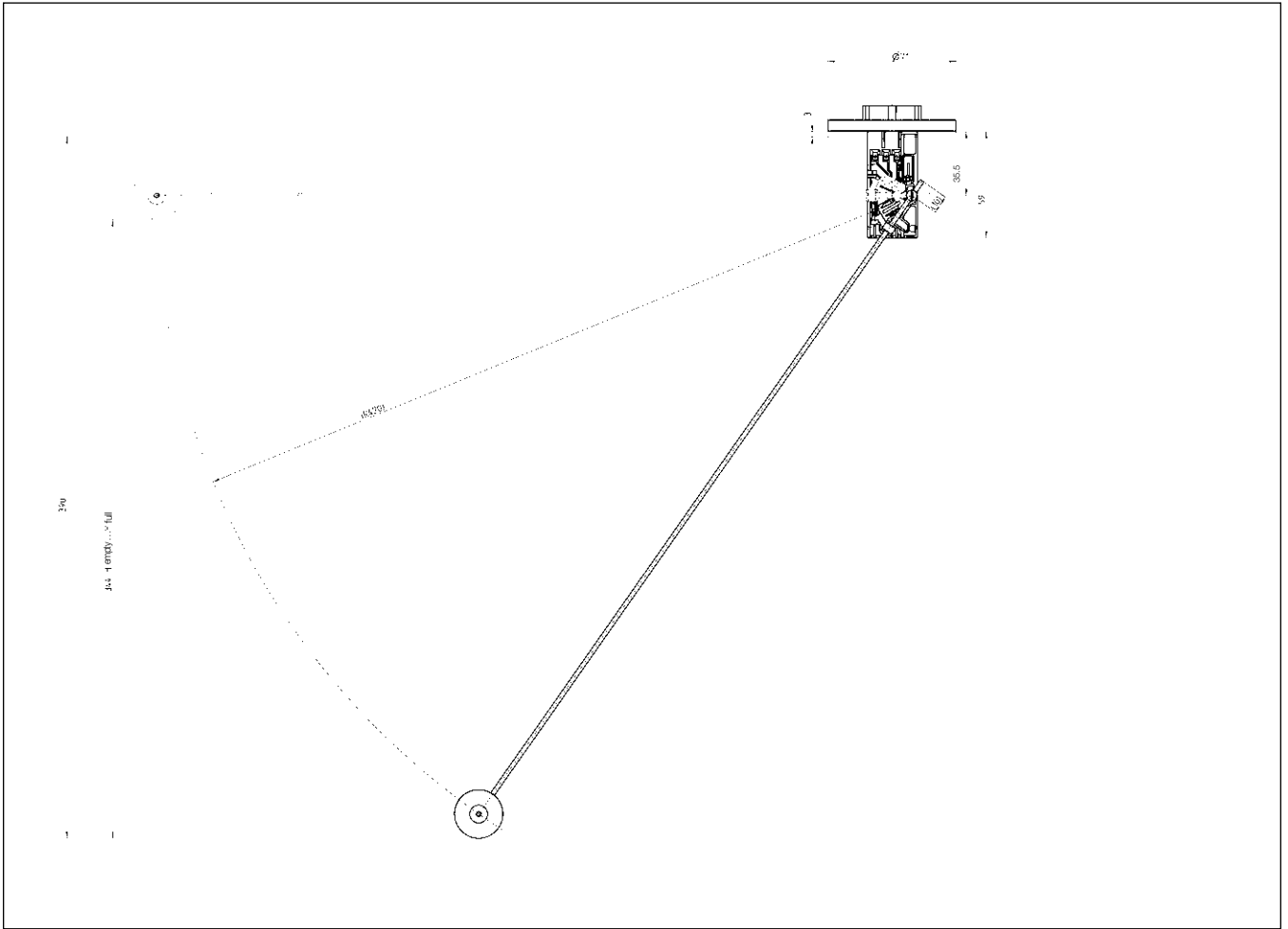

With warning contact

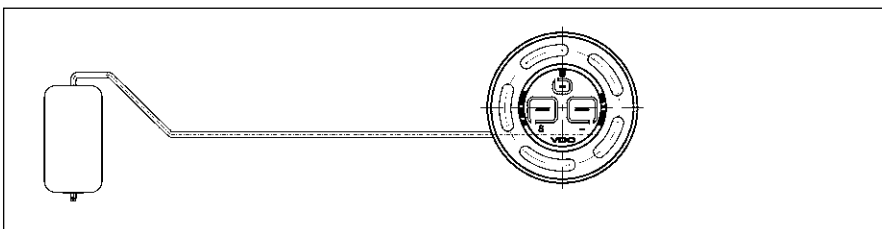

Without warning contact

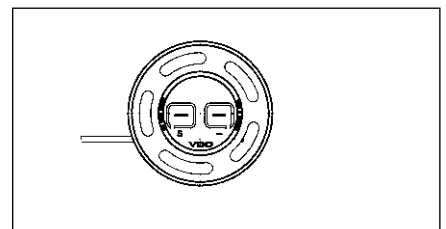

ALAS I characteristics (full-empty)	180-2.5 with warning contact	180-2.5 without warning contact	33.5-240 with warning contact	33.5-240 without warning contact	90-2 with warning contact	90-2 without warning contact
Order number, 1 unit/pack	A2C59510165	A2C59510171	A2C59510166	A2C59510172	A2C59510167	A2C59510173
Order number, 10 units/pack	A2C59510162	A2C59510168	A2C59510163	A2C59510169	A2C59510164	A2C59510170

Technical data

Tank depth	For tank depths from 145 to 400 mm
Rated voltage	6–24 V, insulated return
Resistance ranges	<ul style="list-style-type: none"> • 3 Ω (empty) to 180 Ω (full) • 240 Ω (empty) to 33.5 Ω (full) • 2 Ω (empty) to 90 Ω (full) • Optional warning contact at 15% remaining volume • Measurement resolution of 39 discrete levels • Alternative resistance ranges can be defined according to specific customer requirements
Mounting geometry	5-hole flange with 54 mm diameter
Electrical connection	6.3 mm x 0.8 mm (2 x) 2.8 mm x 0.8 mm (1 x)* *Only on versions with warning contact

3.2.3 Adjustable Lever-Arm Fuel Level Sender, ALAS II

A2C5 number (packaging)	Item description	Contents
-------------------------	------------------	----------



A2C59510946	Adjustable lever-arm sender with inlet and outlet option, 180-2.5 ohms (generic, 10 units/pack)	Sensor assy
A2C59510973	Adjustable lever-arm sender with inlet and outlet option, 33.5-240 ohms (generic, 10 units/pack)	Sensor assy
A2C59510975	Adjustable lever-arm sender with inlet and outlet option, 90-2 ohms (generic, 10 units/pack)	Sensor assy
A2C59511479	Lever (generic, 10 per/pack), individually boxed with outer box	Lever assy



A2C59510949	Inlet, 12 mm (10 per/pack), individually boxed with outer box	Connector assy
A2C59510951	Inlet, 10 mm (10 per/pack), individually boxed with outer box	Connector assy
A2C59510953	Inlet, 8 mm (10 per/pack), individually boxed with outer box	Connector assy
A2C59510955	Inlet, 6.5 mm (10 per/pack), individually boxed with outer box	Connector assy



A2C59510950	Outlet, 12 mm (10 per/pack), individually boxed with outer box	Connector assy
A2C59510952	Outlet, 10 mm (10 per/pack), individually boxed with outer box	Connector assy
A2C59510954	Outlet, 8 mm (10 per/pack), individually boxed with outer box	Connector assy
A2C59510956	Outlet, 6.5 mm (10 per/pack), individually boxed with outer box	Connector assy
A2C59510965	Blanking plug (10 per/pack), multipack	Blanking plug assy

Dimensions [mm]

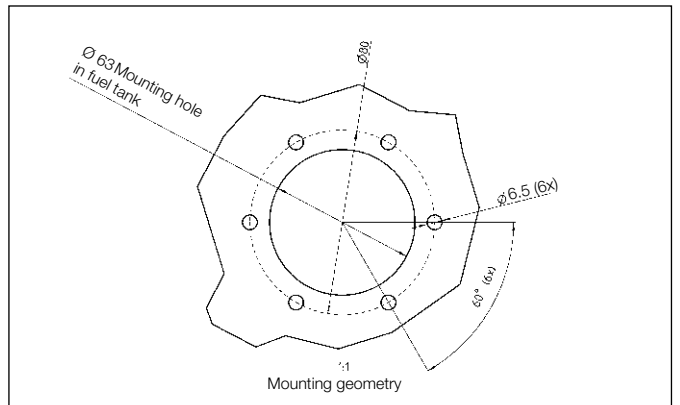
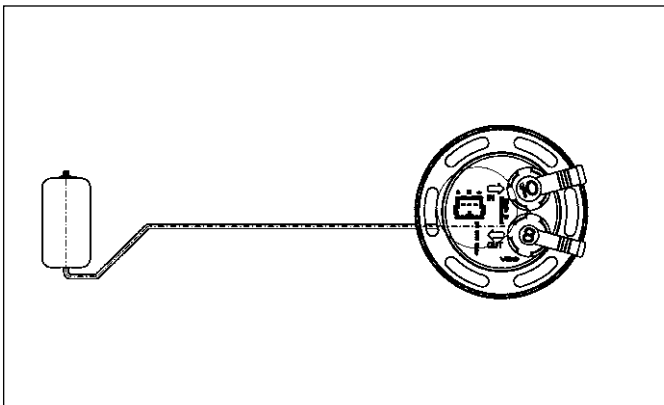
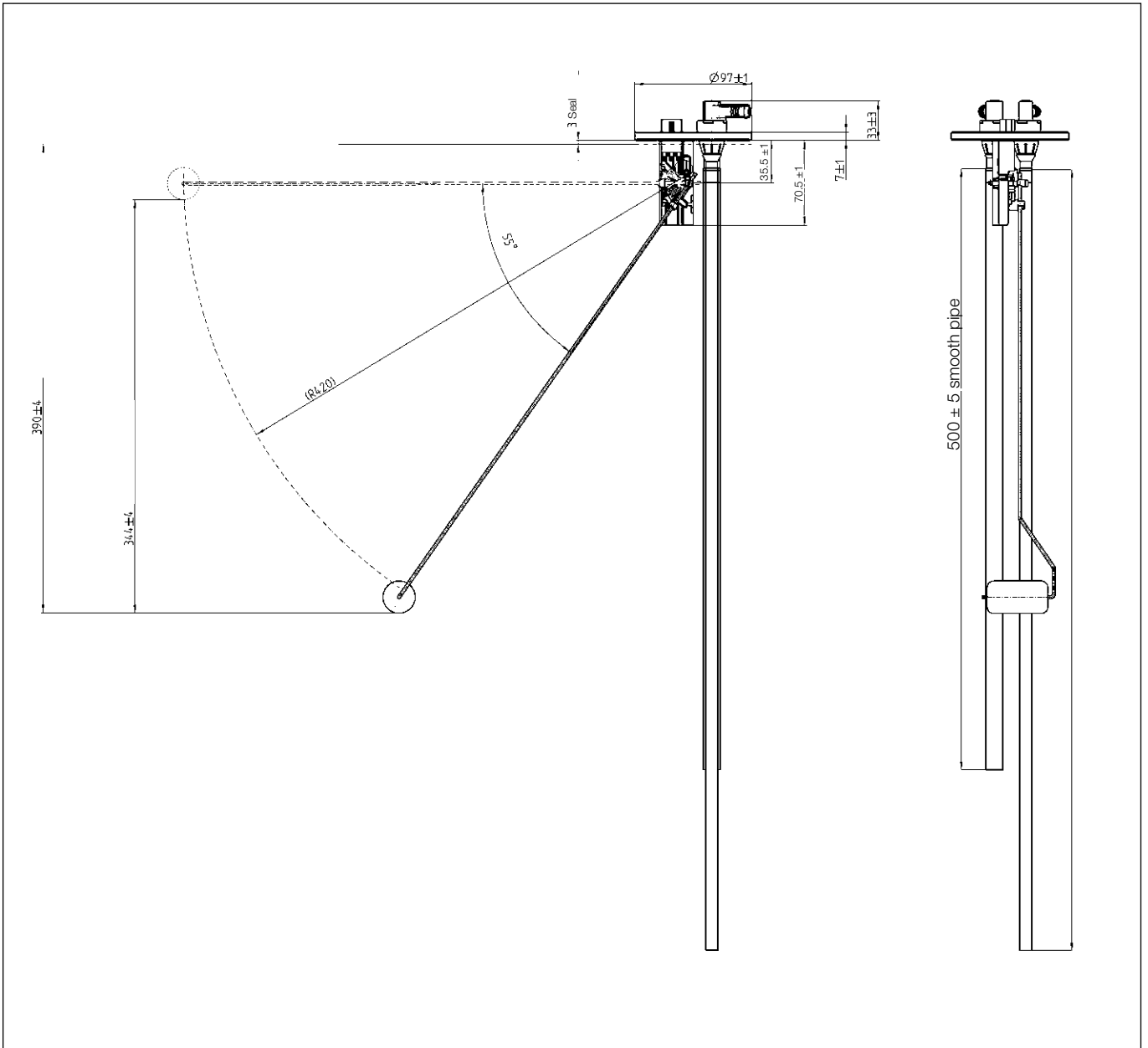



3.3 Water Level Sensors

3.3.1 Fresh Water Level Sensors

3.3.2 Black water Level Sensors

3.3.1 Fresh Water Level Sensors

DIMENSIONS OF SENSOR (MM):

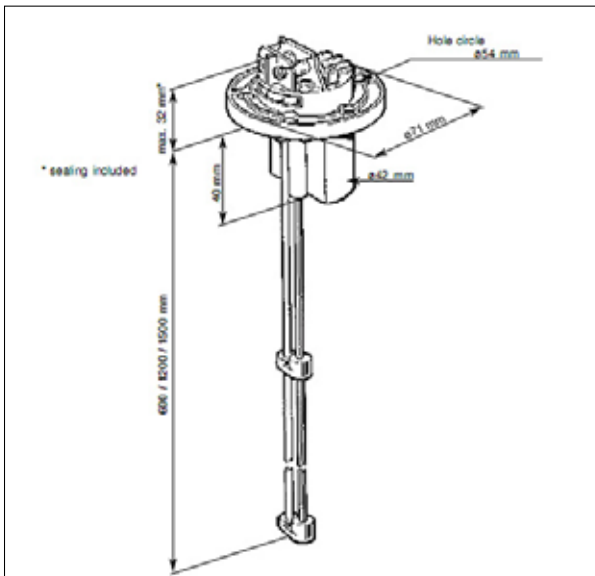

Part number	Tank height
N02-240-402	80 to 600mm
N02-240-404	600 to 1200mm
N02-240-406	1200 1500mm
N05-001-370	Flange

Technical data

Capacitive sensor:	output 4-20mA
For tank height:	80 to 1500 mm
Operating voltage:	da 6V a 24V
Operating temperature:	-30°C a +70°C
Fitting flange:	5 holes Ø 54mm

Lever type fresh water level sensors

INSULATED RETURN, STAINLESS STEEL	
Operating voltage	da 6V a 24V
Tank height	200-600mm
Ohm value	0-180Ω

Part number	Tank height
226-828-001-001K	200 to 600mm



3.3.2 Black Water Level Sensors

Capacitive sensor (galvanic separated) with adjustable warning contact.

DIMENSIONS OF SENSOR (MM):

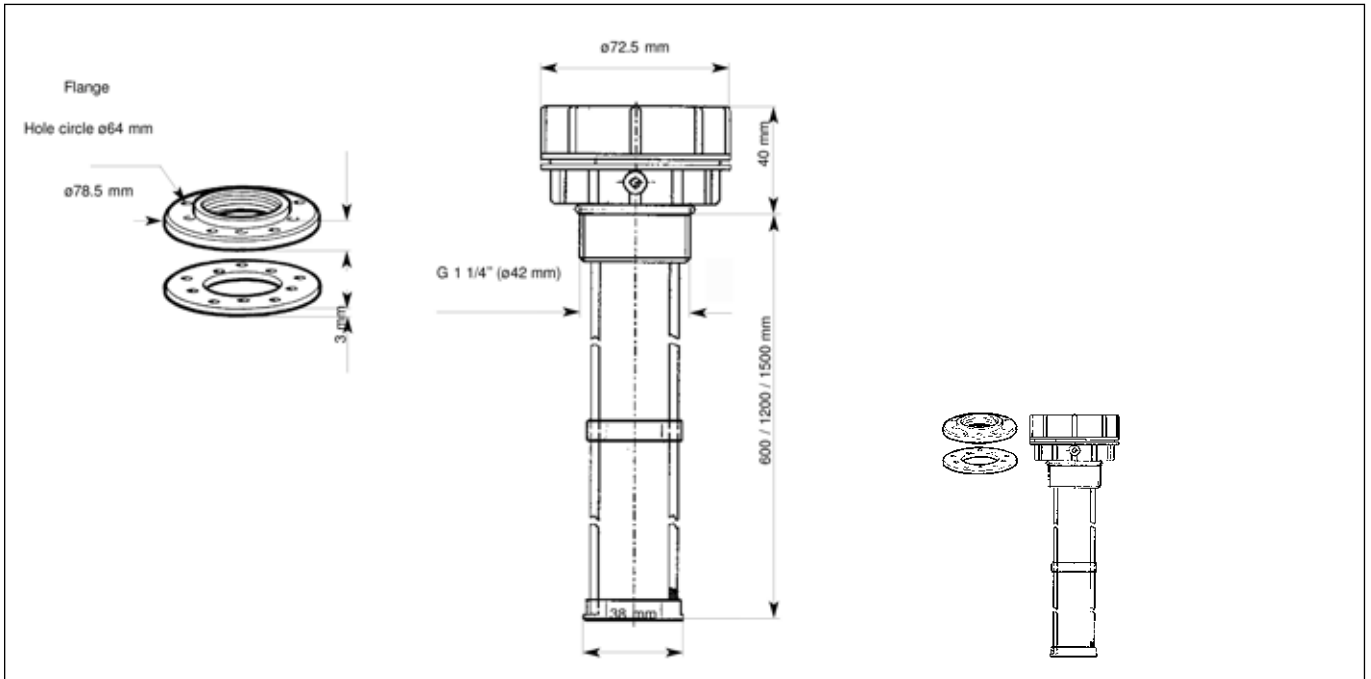

Part number	Tank height
N02-240-902	80 to 600mm
N02-240-904	600 to 1200mm
N02-240-906	1200 to 1500mm
X10-224-000-007	Flange

Technical data

Capacitive sensor:	output 4-20mA
For tank height:	80 to 1500 mm
Operating voltage:	6V-24V
Operating temperature:	-30°C to +70°C



4. Control Systems

- 4.1 Pedal Interface II
- 4.2 AGB III
- 4.3 E-Gas[®] Compact
- 4.4 Actuators

4.1 Pedal Interface II

COMPONENTS, TYPE 1 AND TYPE 2 (KIT INCLUDING HARNESS AND FITTINGS)

Part Number	Description	Type
X10-737-100-001	3-channel analog (tempostat®)	Type 1 Standard
X10-737-101-001	3-channel analog (tempostat® + speed and rev limiter)	Type 1 Enhanced
X10-737-102-001	3-channel analog (tempostat® + speed and rev limiter + engine speed controller)	Type 1 Premium
X10-737-200-001	2-channel analog + 2 switches (tempostat®)	Type 2 Standard
X10-737-201-001	2-channel analog + 2 switches (tempostat® + speed and rev limiter)	Type 2 Enhanced
X10-737-202-001	2-channel analog + 2 switches (tempostat® + speed and rev limiter + engine speed controller)	Type 2 Premium

Technical data	
Rated voltage	12 V / 24 V
Operating voltage	8–32 V
Current consumption	Tmnl. 15 < 1 mA; Tmnl. 30 < 80 mA (< 10 mA standby)
Operating temperature	-40 °C to +85 °C (IEC 68-2-38)

Test specifications	
Low and high temperature	<ul style="list-style-type: none"> • ISO 16750 Part 4, Section 5.1.1.2 and 5.1.2.2 • BS EN 60068-2: 1993 Test Ab • BS EN 60068-2: 1993 Test Bb
Random vibration test in temperature cycle	<ul style="list-style-type: none"> • ISO 16750-3: 2003 Electrical and electronic equipment - Mechanical loads • IEC 68-2-64: 1993, Vibration, broadband random: Method 2 • BS EN 60068-2-14: 2000 Test Nb, Environmental testing
Thermal shock	<ul style="list-style-type: none"> • ISO 16750 Part 4, Section 5.3.3 • BS EN 60068-2-14: 2000 Test Na
Temperature and humidity	<ul style="list-style-type: none"> • ISO 16750 Part 4, Section 5.6.2 • BS EN 60068-2-38: 1999
Temperature cycling	<ul style="list-style-type: none"> • ISO 16750 Part 4, Section 5.3.2 • BS EN 60068-2-14: 2000 Test Nb
Approval acc. to EU directives	Speed limitation devices 92/24 (Enhanced and Premium versions only) EMC 2006/96 EG
Official appointed expert	Tempostat functionality tested by a prescribed testing authority for the approval of motor vehicles and their systems, Germany

INSTALLATION KIT (REPLACEMENT PART)

Part Number: X39-737-300-003

WIRING HARNESS (REPLACEMENT PART)



Part Number: X39-737-300-008

MANUAL CONTROL INTERFACE FOR ENGINE SPEED CONTROLLER (ACCESSORY)

Only for use under protected conditions



Part Number: X39-737-003-003

PEDAL INTERFACE DONGLE (TEST EQUIPMENT)

Only for use under protected conditions

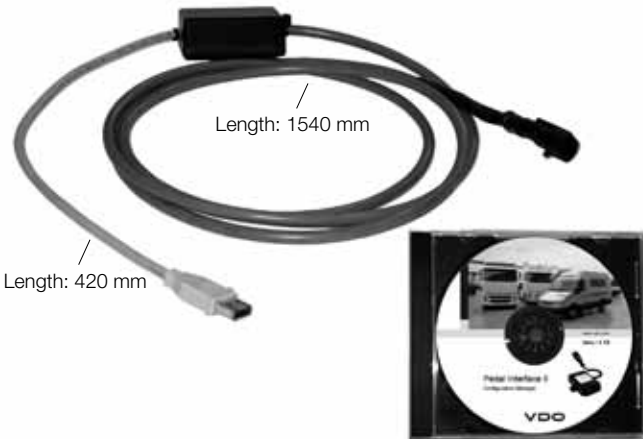

Dongle for workshops

Part Number	Name	Description
X12-737-100-002	Pedal Interface Dongle Level 2	Workshop dongle: Allows access to all functions, including maximum speed limiter.
X12-737-100-003	Pedal Interface Dongle Level 3	This dongle allows access to tempostat® functions and engine speed controller (fixed engine speed control, variable engine speed control, gas pedal position limiter)

STANDARD OPERATING LEVER (ACCESSORY)

System component for tempostat® 12 V, AGB Komfort, E-Gas®, II E-Gas® compact, Pedal Interface II



Part Number: X39-397-106-149

LED OPERATING LEVER, RIGHT - 12 V APPLICATIONS ONLY (ACCESSORY)



Part Number: X39-737-300-004 - X39-737-300-005

OPERATING LEVER, RIGHT, FLEXIBLE (ACCESSORY)



Part Number: X39-737-300-006 - X39-737-300-007

4.2 AGB III

AUTOMATIC SPEED LIMITER

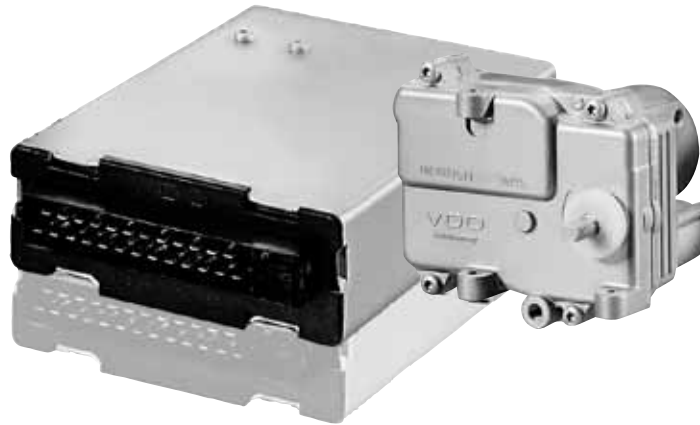

Parts included (complete: 1 = 12 V / 1.1 = 24 V)

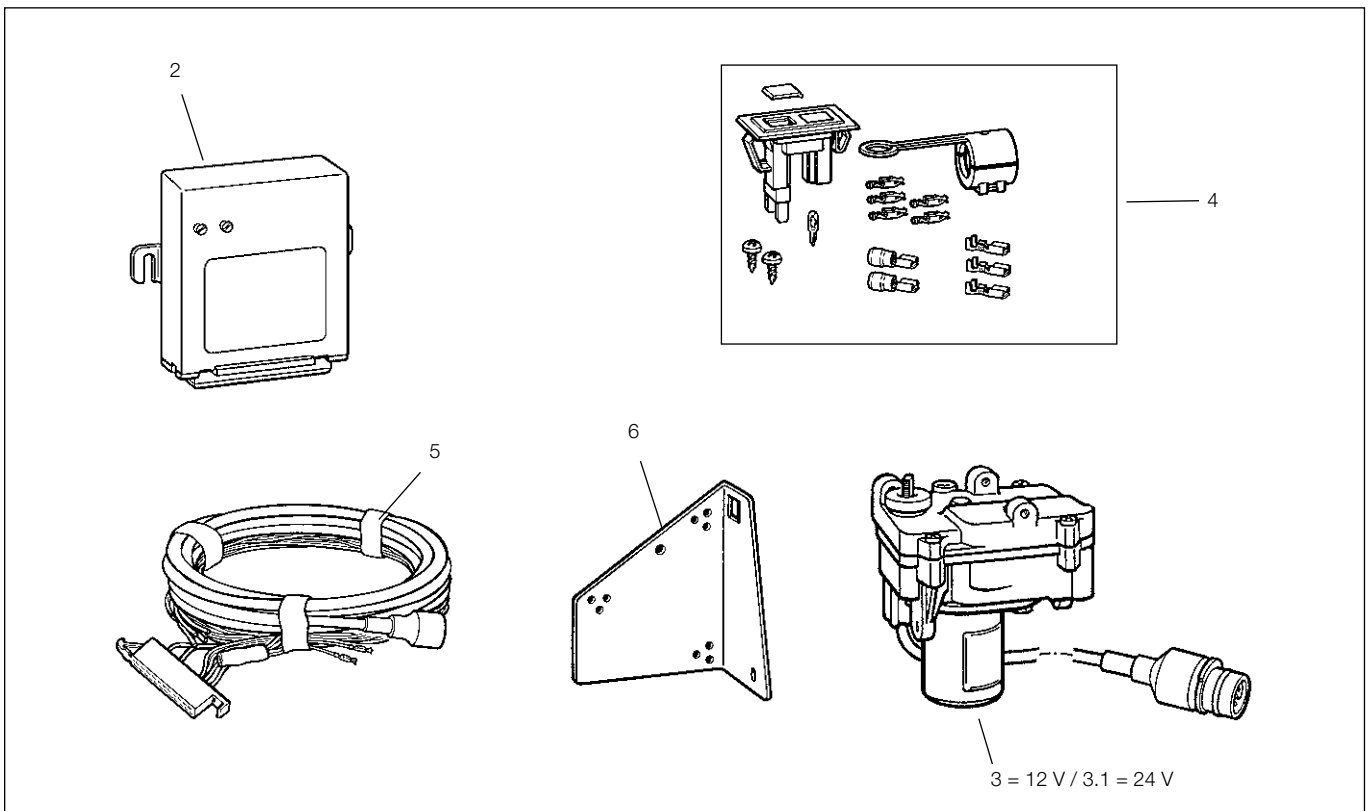

Part Number	Description	Item
X10-397-109-131	AGB III Basic Kit 12 V	1
X10-397-109-132	AGB III Basic Kit 24 V	1.1
REPLACEMENT PARTS		
A2C53091782	Electronic controller 12/24 V	2
408-221-001-001 P	Actuator 12 V	3
408-422-001-014 G	Actuator 24 V	3.1
X39-397-109-027	Electrical set	4
X39-397-109-030	Wiring harness	5
X11-397-001-033	Bracket, actuator	6

4.3 E-Gas[®] Compact

ELECTRONIC CONTROLLER

SYSTEM COMPONENT FOR E-GAS[®] COMPACT

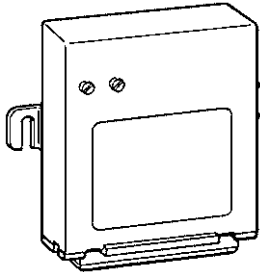

Part Number: 412-413-011-002P*

*Supplied on request - limited availability

Technical data

Rated voltage	12 V / 24 V
Operating voltage	9.5-32 V
Operating temperature	-40 °C to +70 °C
Protection rating	IP53 DIN 40050
Installation location	Passenger compartment
Orientation	Electrical connection facing down (minimum 5°)
Connector	25-pole AMP

Description

This electronic controller has been designed for use in off-highway vehicles.

The system operates the fuel control lever of an internal combustion engine by means of an actuator, which moves according to a set of pre-defined set points. All input and output signals are processed by an integrated 16-bit processor. Thanks to the flexibility of its design, the controller can be programmed to meet a wide range of requirements, such as:

- Pedal-by-wire.
- Engine speed control and limitation.
- Vehicle speed control and limitation.
- Position limitation.

A custom PC-based software tool allows the controller to be accessed as necessary via the diagnostics interface in order to change the calibration or read out diagnostic trouble codes.

The controller complies with the following standards:

- 2006/96/EC Automotive EMC Directive.
- Directive 92/24/EEC relating to speed limitation devices.
- DIN 40839 Interferences conducted along supply lines.

Dimensions [mm]

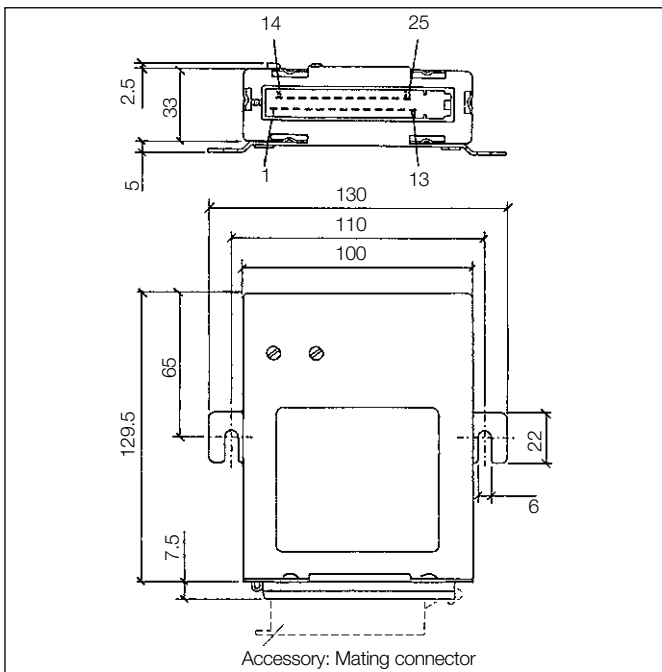

Terminal assignment

- | | |
|----|-------------------------------|
| 1 | Terminal 15 |
| 2 | Motor (-) |
| 3 | Clutch switch |
| 4 | Fixed engine speed control ON |
| 5 | Pedal unit PWM 1 |
| 6 | Prog. limiter |
| 7 | tempostat [®] memo |
| 8 | Brake signal |
| 9 | Rotational speed |
| 10 | Actuator feedback |
| 11 | Pot. connector (+) |
| 12 | Pot. connector (-) |
| 13 | Fault light and button |
| 14 | Terminal 31 (ground) |
| 15 | Motor (+) |
| 16 | tempostat [®] off |
| 17 | Pedal unit PWM 2 |
| 18 | Clutch |
| 19 | tempostat [®] S-B |
| 20 | tempostat [®] S+B |
| 21 | Speed signal |
| 22 | Not connected |
| 23 | Diagnostics K-line |
| 24 | Pot. wiper |
| 25 | Analog input |

Part Number	Product
X11-397-109-003	Mating connector, edge connector, black
X11-397-109-004	Connector sleeve

SET POINT SENDER

SYSTEM COMPONENT FOR E-GAS® II, E-GAS® COMPACT

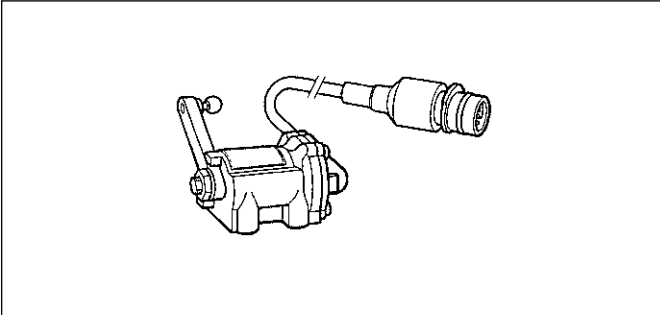

Part Number: 445-804-005-014P

Description

Set point senders use a potentiometer to convert a pedal position into an electrical signal. The potentiometer wiper is positively connected to the driving lever via the potentiometer and drive shaft. The potentiometer housing is positively connected with the aluminum housing. The set point signal is always available. A safety contact (SK) and kick-down contact (KD) are actuated within a predefined range. The safety contact corresponds to a specific potentiometer value. The actuating cam is positively connected with the drive shaft. When the driving lever moves from full-load to no-load, the safety contact is positively opened. Fatigue-resistant contact springs are used.

Technical data

Power supply via electronic controller

Operating temperature	-40 °C to +80 °C
Initial torque	160 Ncm ^{+20 Ncm} _{-30 Ncm}
Final torque	280 Ncm ± 40 Ncm
Kick-down torque	550 Ncm ± 70 Ncm
Hysteresis	50 Ncm ± 20 Ncm at no-load 50 Ncm ± 20 Ncm at full-load
Protection rating	IP66 DIN 40050
Max. tightening torque for fastening screws	8 Nm + 4 Nm (at 9 mm screw-in depth)
Connector	ITT Canon Sure Seal, 7-pin

Dimensions [mm]

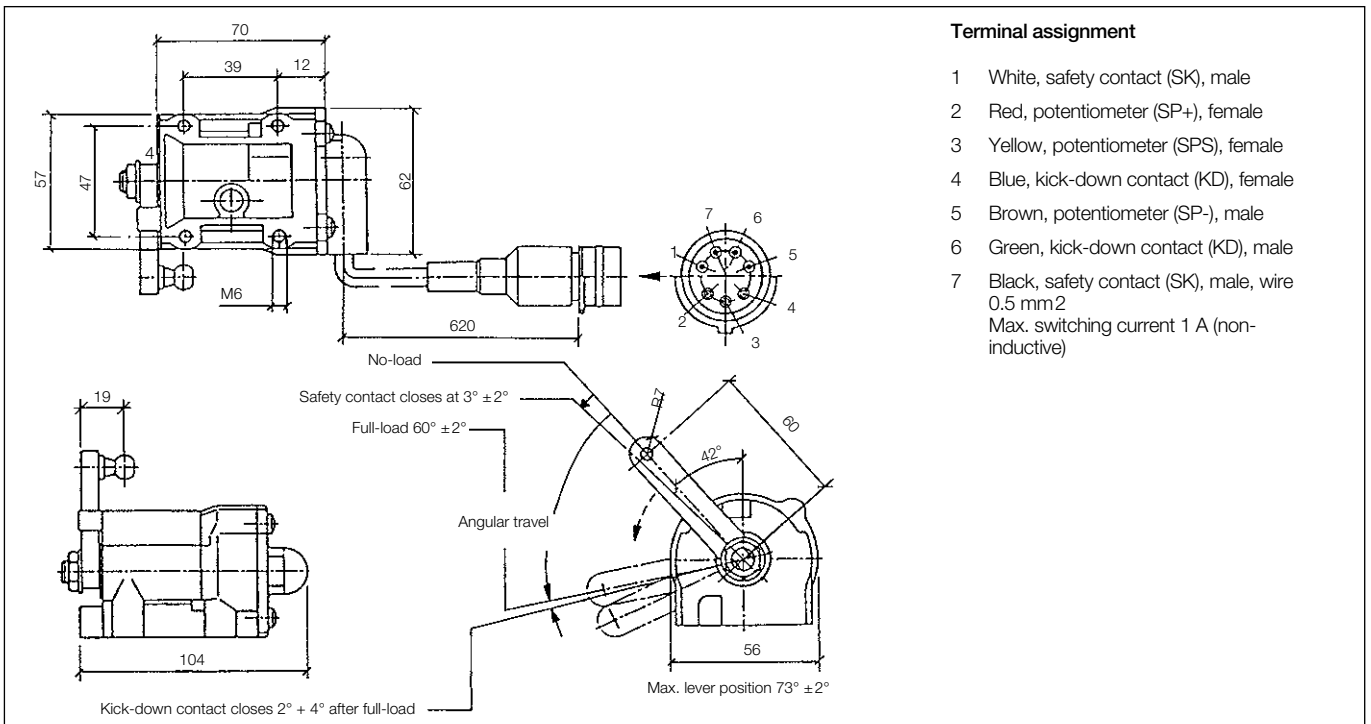

SOFTWARE

Part Number

X12-397-051-001	E-Gas® Compact Testsoftware V.4002 WinXP
X12-397-046-001	E-Gas® Compact Testsoftware V.4002 WinXP Interface Included

ELECTRICAL ACTUATOR

SYSTEM COMPONENT FOR E-GAS® II, E-GAS® COMPACT

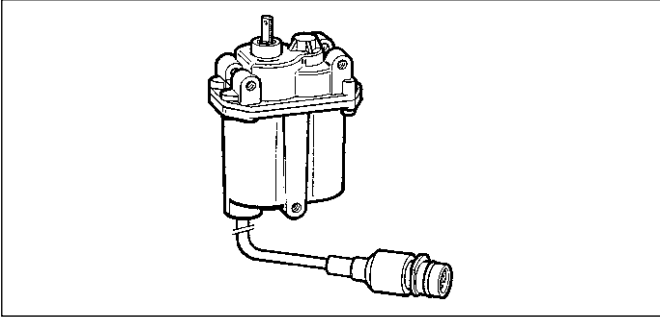

Part Number: 408-411-005-013P (24 V) | 408-211-004-002P (12 V)

Description

This electrical actuator was designed by VDO for the purpose of operating a diesel engine fuel-injection pump lever in conjunction with a VDO electronic controller.

Construction

Watertight cast aluminum housing with PTFE membrane for pressure equalization. Three-stage transmission permanently engaged with output shaft. A conductive plastic potentiometer provides feedback. Features a safety contact that opens when output shaft is at a pre-defined position. Connecting cable with connector.

Technical data

Rated voltage	24 V or 12 V
Rated torque	180 Ncm (used in conjunction with elec. controller)
Actuation time	< 250 ms at rated voltage 100 to 180 Ncm actuating torque
Safety contact switching point	21° to 12.5° (closed at no-load)
Operating temperature	-40 °C to +120 °C (+140 °C max. 1 x 1h)
Protection rating	IP56 DIN 40050
Mechanical angle	120°
Max. tightening torque for drive shaft	10 Nm
Max. tightening torque for fastening screws	8 Nm + 4 Nm (at 9 mm screw-in depth)
Connector	ITT Canon Sure Seal, 7-pin

Dimensions [mm]

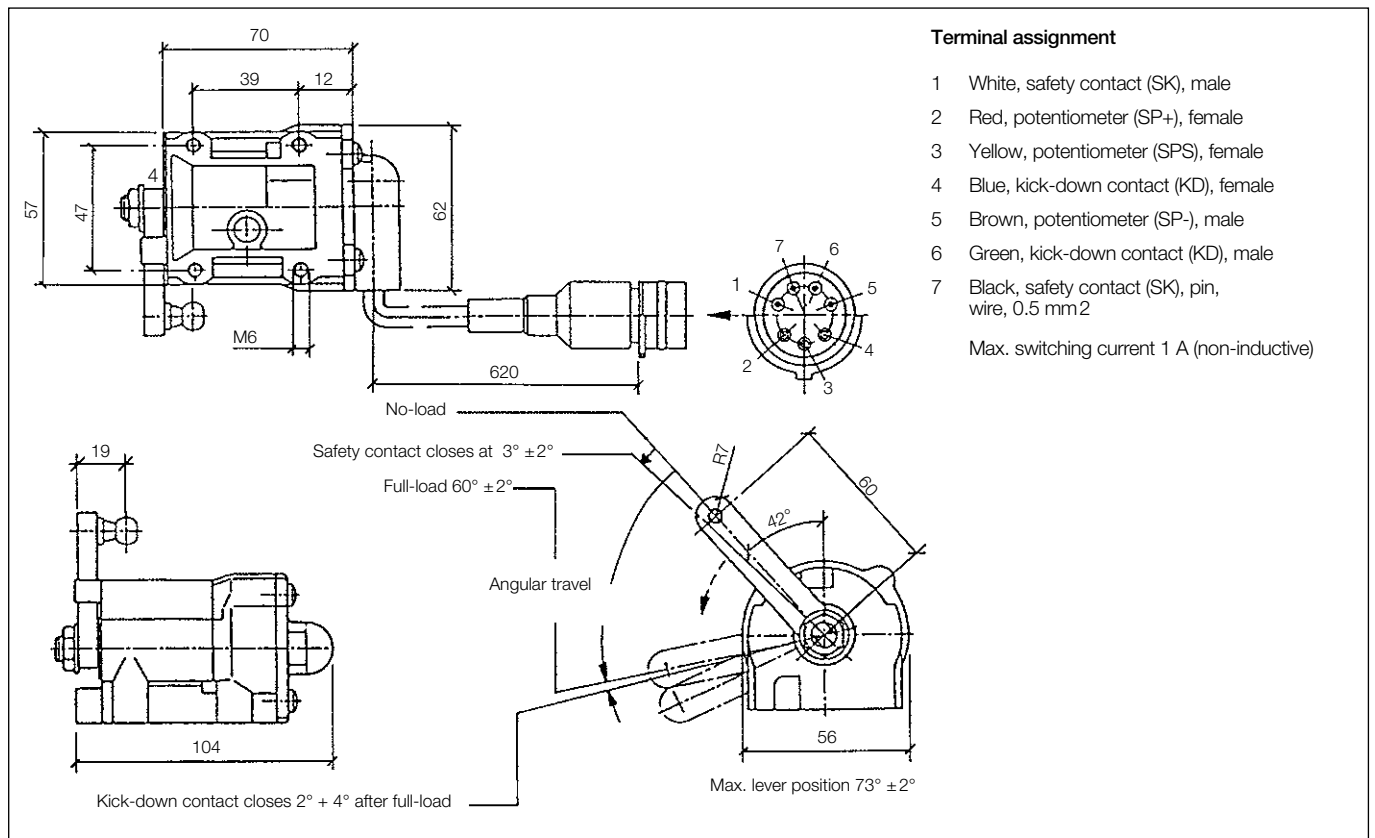

4.4 Actuators

ELECTRICAL ACTUATOR

SYSTEM COMPONENT FOR E-GAS® COMPACT

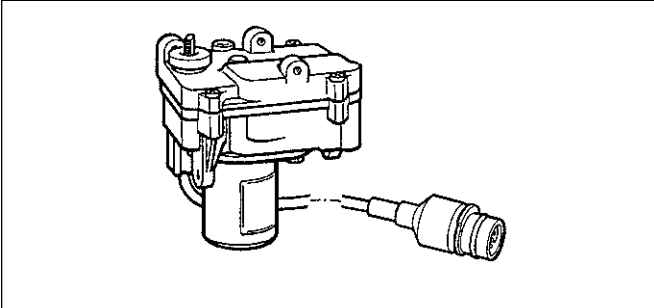

Part Number: 408-422-006-001G

Please refer also to technical customer document 408-422-006-001G.

Description

This electrical actuator was designed by VDO for the purpose of operating a diesel engine fuel-injection pump lever in conjunction with a VDO electronic controller. A pulse-width modulated (PWM) signal is used to control the permanent magnet DC motor.

Construction

Watertight cast aluminum housing with PTFE membrane for pressure equalization. Three-stage transmission transfers force from the DC motor to the output shaft via an electromagnetic clutch. A conductive plastic potentiometer provides feedback. Connecting cable with connector.

Technical data

Rated voltage	24 V
Rated torque	250 Ncm
Closed-to-open stroke time	≤ 1 s
Closed-to-open stroke time (typical)	750 ms
Insulation resistance	≥ 500 kΩ
Dielectric strength	500 V
Operating temperature	-25 °C to +90 °C
Protection rating	IP56 DIN 40050 Part 9
Max. tightening torque for drive shaft	10 Nm
Max. tightening torque for fastening screws	12 Nm (at 9 mm screw-in depth)
Mechanical angle	103° ± 5°
Connector	ITT Canon Sure Seal, 7-pin

Dimensions [mm]

Terminal assignment

- 1 Motor (-)
- 2 Potentiometer (IP-)
- 3 Potentiometer (IPS)
- 4 Potentiometer (IP+)
- 5 Clutch
- 6 Clutch
- 7 Motor (+)

Part Number	Product
X39-397-112-014	2 actuator bracket set (for engine mounting)

Dimensions [mm]

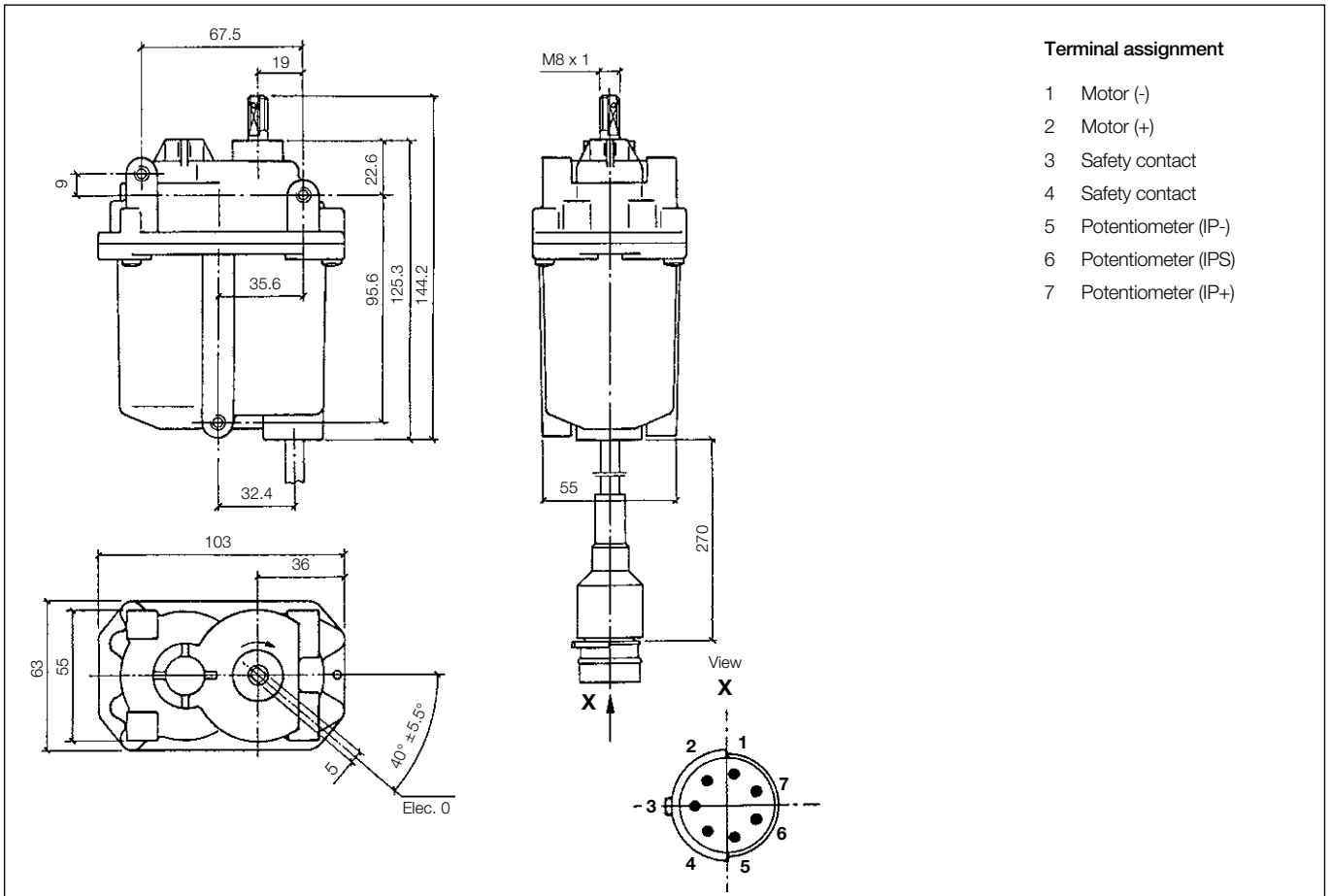

Part Number	Product
240-110-001-001P	Damping elements (set)
993-620-079-1143	Lever (angled)
993-620-082-1143	Lever (straight)

SYSTEM COMPONENT FOR E-GAS® COMPACT, AGB KOMFORT

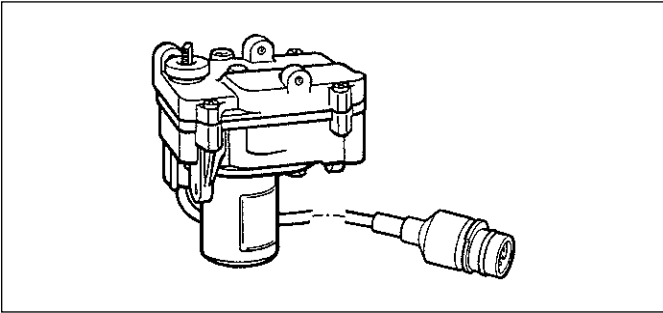

Part Number: 408-221-005-001G

Please refer also to technical customer document 408-221-005-001.

Description

This electrical actuator was designed by VDO for the purpose of operating a diesel engine fuel-injection pump lever in conjunction with a VDO electronic controller. A pulse-width modulated (PWM) signal is used to control the permanent magnet DC motor.

Construction

Watertight cast aluminum housing with PTFE membrane for pressure equalization. Three-stage transmission transfers force from the DC motor to the output shaft via an electromagnetic clutch. A conductive plastic potentiometer provides feedback. Connecting cable with connector.

Technical data

Rated voltage	12 V
Rated torque	400 Ncm counterclockwise (AGB) 300 Ncm clockwise (tempostat®)
Closed-to-open stroke time	≤ 2 s
Insulation resistance	≥ 500 kΩ
Dielectric strength	500 V
Operating temperature	-25 °C to +90 °C
Protection rating	IP56 DIN 40050 Part 9
Max. tightening torque for drive shaft	10 Nm
Max. tightening torque for fastening screws	12 Nm (at 9 mm screw-in depth)
Mechanical angle	103° ± 5°
Connector	ITT Canon Sure Seal, 7-pin

Dimensions [mm]

Terminal assignment

- 1 Motor (-)
- 2 Potentiometer (IP-)
- 3 Potentiometer (IPS)
- 4 Potentiometer (IP+)
- 5 Clutch
- 6 Clutch
- 7 Motor (+)

Part Number	Product
240-110-001-001P	Damping elements (set)
X39-397-112-014	Actuator bracket set (for engine mounting)



4.5 KIBES (Key to Integrated OnBoard Electronic Systems)

In modern vehicles and machines increasing requirements regarding efficiency, comfort and functionality effects the development. Electronic Network Solutions from Continental can meet this future challenge. From fixed over-dimensioned wiring harnesses and

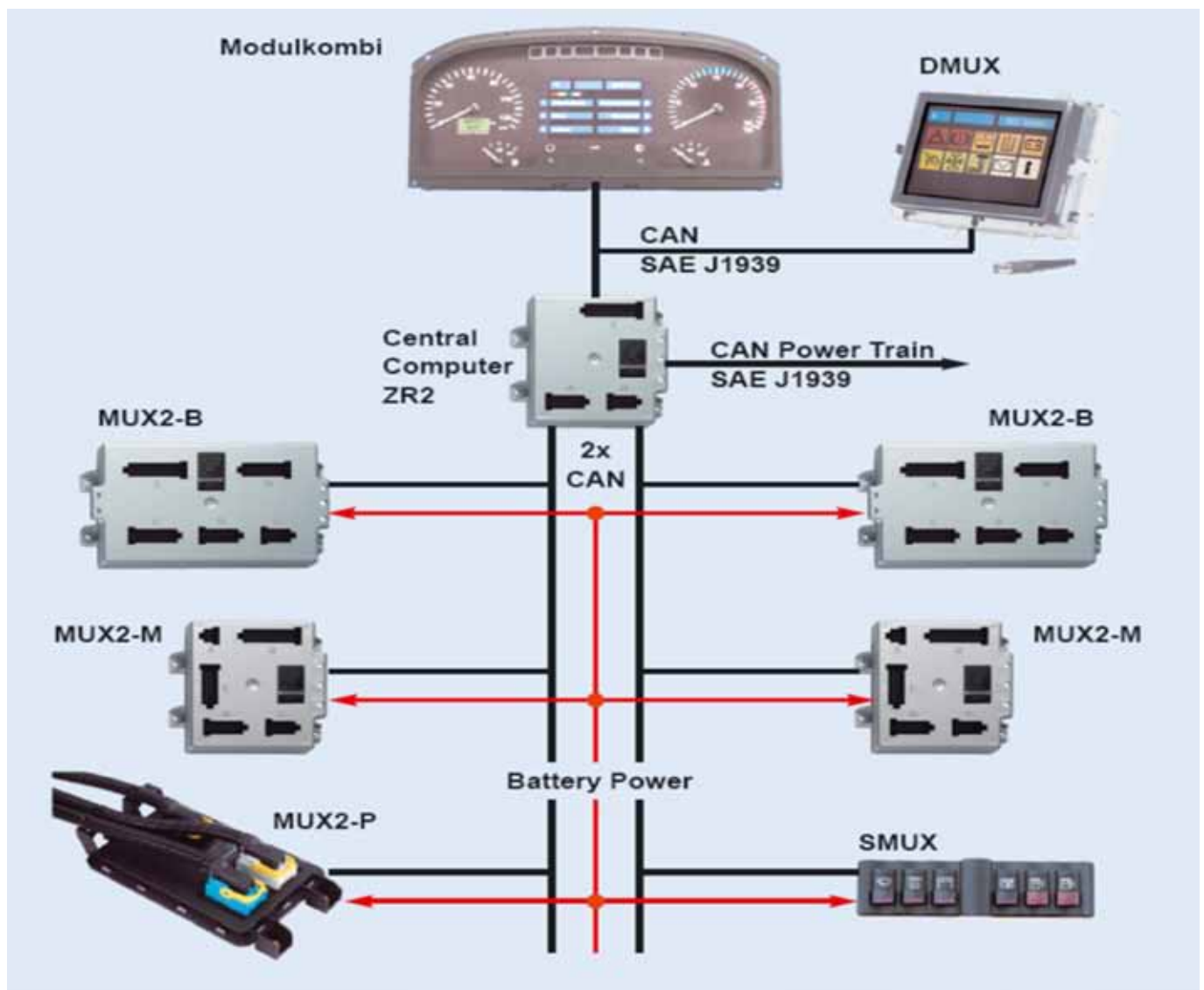
conventional electrics there will be a change to flexible architecture with divided intelligent power and diagnosis, direct interface to the driver display and Gateway to data busses.



Technical Characteristics

Reference Table	MUX2-M	MUX2-B	MUX2-P
			
Dimensions (mm) LxBxH	162 x 165 x 30	228 x 155 x 30	240 x 170 x 40
Nominal voltage	12V and 24V	12V and 24V	12V and 24V
Operating voltage	8-32V	8-32V	8-16 or 16-32V
Operating temperature	-30°C ... +70°C	-30°C ... +70°C	-40°C ... +85°C
IP Protection	IP40	IP40	IP67 IP69K)
SAEJ1455	yes	yes	yes
INPUT digital	12	24	12
analog (parametric)	2	6	12
OUTPUT High Side 12A	-	-	1
10A	-	2	1
6A	-	-	6
5A	-	4	-
3A	14	10	2
1.5A	-	-	1
* HB switch 1A (3A)	-	8	2
Low Side * HB switch	1A (3A)	-	-
* HB switch, one shot	1A (3A)	-	-
* HB switch, one shot	PWM 2 with 1A each	3 with 1A each	2 with 1A - 1 with 3A - 1 with 6A
Max. current at same time	25A	30A	67.5A
No. of Supply Groups (15A)	2	5	5
Solid State Relay with 40 mA each	-	-	2 (4 Pin)

Reference Table SMUX-MASTER - SMUX-SLAVE



Dimensions (mm) LxBxH	155 x 45 x 50
Nominal voltage	12V and 24V
Operating voltage	10.8-32V
Current supply	max. 500mA
Standby current consumption	2.5mA / 24V
Operating temperature	-20°C ... +50°C
Storage temperature	-40°C ... +80°C
IP Protection	IP54 front side IP20 rear side incl. connector
INTERFACES	
CAN	ISO 11898 250 kbit/s
Interface to slave	max. 2 slaves
Switches master	6 switches
Switches slave	6 switches
Dimming (PWM)	Function & night illumination

Technical Characteristics

Reference Table	DMUX32-C	DMUX32-M
		
Dimensions (mm) LxBxH	173.13 x 158.5 x 68.7	173.1 x 158.6 x 68.7
Nominal voltage	24V	24V
Operating voltage	21.5-30V	21.5-30V
Current supply	500mA	300mA
Standby current consumption	5mA	5mA
Operating temperature	-20°C ... +50°C	-20°C ... +70°C
Storage temperature	-40°C ... +80°C	-40°C ... +80°C
IP Protection	IP20	IP20
Weight	approx. 800g	approx. 750g
CAN I_CAN	ISO 11898	ISO 11898
MC_CAN	ISO 11519	ISO 11519
Res_CAN	ISO 11898 (optional)	ISO 11898 (optional)
Diagnostic / Programming	Serial K-Line-Interface according to ISO 9141	
Steering wheel key	ISO 9141	-
Speakers	1 Watt speaker (at 8 W)	-
Video input for cameras	PAL / NTSC	-
Display resolution	320 * 234 pixel	160 * 128 pixel
Visibility	101 * 74 mm	95 * 76 mm
Technologie	Color TFT	Monochrome FSTN
Illumination	CCFL	LED
Dimming	yes	yes
Heating	yes	no

Reference Table	MODULKOMBI
	
Dimensions (mm) LxBxH	155 x 45 x 50
Nominal voltage	12V and 24V
Operating voltage	10.8-32V
Current supply	max. 500mA
Standby current consumption	2.5mA / 24V
Operating temperature	-20°C ... +50°C
Storage temperature	-40°C ... +80°C
IP Protection	IP54 front side IP20 rear side incl. connector
INTERFACES	
CAN	ISO 11898 250 kbit/s
Interface to slave	max. 2 slaves
Switches master	6 switches
Switches slave	6 switches
Dimming (PWM)	Function & night illumination

Reference Table	MODULKOMBI
------------------------	-------------------



HARDWARE	
Processor	2 x 32 Bit RISC
Internal flash	2 x 512 kbyte
External flash	2 Mbyte
External SRAM / External EEPROM	256 kbyte / 32 kbyte
Connector AMP	3 + 1 (+1 reserved) 3 connectors pin compatible to ZR2 family
SOFTWARE	
PLC core package	32-Bit Windows technology
Operating System, Host (PC)	Windows NT 4.0, 2000, XP
OEM-development environment	Modular Base Resource Type (MBRT)
EEProm access	Generic EEPROM
Version Control for PLC projects	yes
Diagnosis	Diagnosis 1B (separate spec.)
Operating System, on target Hardware	OSEK
INTERFACES AND I/O	
• PCAN (powertrain)	Modified powertrain 3 (separate spec.) MTCO, DTDO
Generic CAN Objects	15 rx / 10 tx
• ICAN (instrumentation)	DMUX32-C/M, MOKI, SMUX2000, MTCO, DTDO
• MCAN1 (body can) *	MUX2-B, MUX2-M, SMUX2000
• MCAN2 (body can) *	(max. 2 x 8 nodes), MUX2-P
• KCAN (Karosserie, body)	Karosserie 3 (separate spec.) Door control MTS, Pronova
Generic CAN Objects	10 rx / 5 tx
• XCAN CANopen Application layer (EN50325-4)	Basic driver
IBIS CANopen (VDV/EN13149-4/5/6)	future software enhancement
IBIS Interface (VDV 300; 1984/1992)	yes
RS232 (Modem interface)	Interface only (prepared for optional Remote Diagnostic)
SAE J1587/J1708	Yes (Rx only)
Digital Output (100mA LowSide)	2+7
Digital Input	7 (alternative to 7 Outputs)
Wake Up signals	3
Analog Input	Battery voltage
Diagnostic I/O (blink code)	1 (system status)
EOL End Of Line programming	K-Line interface (KWP2000)
Diagnostic Services	K-Line interface (KWP2000; ASAM)



5. Accelerator Pedals

5.1 Pedals

5.2 Hand-Operated Accelerators and Pedal Sensors

5.1.1 Floor-Mounted Pedal

The floor-mounted pedal is composed of a base-plate for mounting in the passenger compartment and a pre-fitted pedal plate (aluminum ADC12, injection molded, black finish, 66 % nylon, 30 % GFRP). Two return springs are used to replicate the pedal forces and direction-dependent hysteresis; twin return springs are used for added safety. Pedal position feedback is provided by a contactless sensor connected to either an analog or a PWM (pulse width modulated) signal circuit, depending on the variant. The no-load state can be detected either by an optocoupler or mechanically via a microswitch, according to the application.

Product	Engine Type	Sensor Type	Sensor 1	Sensor 2	IVS1	IVS2	Drw
Floor Mounted (FMP) Pedal Angle 39°							
A2C59515512		1x analog, 2x switches	0.4 - 4.0 V		0.6 V NC	0.71 V NO	A
A2C59515514		1x analog, 1x switch	0.4 - 5.15 V		0.7 V NO		
X10-445-001-002	Caterpillar (3000 Series), perkins	1x analog, 1x switch	0.4 - 4.15 V		0.6 V NC		
X10-445-001-004	Cummins Euro 3	1x analog, 2x switches	0.4 - 4.0 V		0.6 V NC	0.71 V NO	
X10-445-001-006	MAN	2x analog, 1x switch	0.4 - 3 V	0.4 - 4.5 V	0.8 V NO		
X10-445-001-007	Scania DEC2	2x analog, 1x switch	0.4 - 4.5 V	0.4 - 3.25 V	0.6 V NO		
X10-445-001-015	Iveco engine	2x analog, 1x switch	0.45 - 4.0 V	0.5 - 4.5 V	0.8 V NO		
X10-445-001-019	Bosch ECU Application	2x analog	0.75 - 4.0 V	0.375 - 2.0 V			
X10-445-050-014	Iveco	1x analog, 1x switch	0.45 - 4.0 V				
Floor Mounted (FMP) Pedal Angle 45°							
A2C59515503		1x analog, 2x switches	0.4 - 4.0 V		0.6 V NC	0.71 V NO	B
A2C59515505		2x analog, 2x switches	0.5 - 4.5 V	4.5 - 0.5 V	0.7 V NC	0.8 V NO	
A2C59515507		1x analog, 1x switch	0.4 - 4.1 V		0.8 V NO		
A2C59515509		Dual Cross PWM	PWM 24% - 76% 200Hz	PWM 76% - 24% 200Hz			
A2C59515510		1x analog, 1x switch	0.5 - 4.5 V		0.6 V NC		
A2C59515511		2x analog	0.55 - 2.1 V	1.1 - 4.2 V			
A2C59515528		Dual Cross PWM	PWM 24% - 76% 200Hz	PWM 76% - 24% 200Hz			
A2C59515531		1x analog, 1x switch	0.4 - 4.1 V		0.8 V NO		
A2C59515565		2x analog	0.55 - 2.1 V	1.1 - 4.2 V			
A2C59515705		1x analog, 2x switches	0.5 - 4.5 V		0.7 V NC	0.8 V NO	
A2C59515725		1x analog, 1x switch	0.4 - 4.1 V		0.8 V NO		
A2C59517960	Mercedes - Special Application	Dual Cross PWM, 1x analog 0.4 - 4V	PWM 22% - 71% 500Hz	PWM 78% - 29% 200Hz			
X10-445-100-002	Caterpillar (3000 Series), perkins	1x analog, 1x switch	0.4 - 4.15 V		0.6 V NC		
X10-445-100-004	Cummins Euro 3	1x analog, 2x switches	0.4 - 4.0 V		0.6 V NC	0.71 V NO	
X10-445-100-006	MAN	2x analog, 1x switch	0.4 - 3 V	0.4 - 4.5 V	0.8 V NO		
X10-445-100-010	UK Customer Application	2x analog	0.4 - 3.25 V	0.4 - 4.5 V			
X10-445-300-003	Cummins	1x analog, 2x switches	0.4 - 4.0 V		0.6 V NC	0.71 V NO	
Floor mounted (FM P) Pedal Angle 31°							
A2C59511729	Customer Specific Interface	1x analog, 1x switch	0.65 - 4.3 V		0.9 V NA		C
A2C59513725		2x analog	0.5 - 4.5 V	4.5 - 0.5 V			
A2C59515517		2x analog	0.4 - 4.5 V	0.4 - 3.0 V			
A2C59515520		2x analog	0.55 - 2.1 V	1.1 - 4.2 V			
X10-445-400-001	VM, MTU, John Deere, Detroit diesel, Deutz, Iveco, Isotta Fraschini	1x analog, 2x switches	0.4 - 4.0 V		0.6 V NC	0.71 V NO	
X10-445-400-004	Cummins Euro 3	1x analog, 2x switches	0.4 - 4.0 V		0.6 V NC	0.71 V NO	

DRAWINGS

FLOOR-MOUNTED PEDAL (FMP) ANGLE 39° - DRAWING A



Technical Data

Operating temperature:	-40 °C to +85 °C
Protection:	IP 6k7k
Installation place:	Interior
Angle of actuation:	17.5° ± 2°

For additional information please refer to the technical drawing of the specific Part. NO.

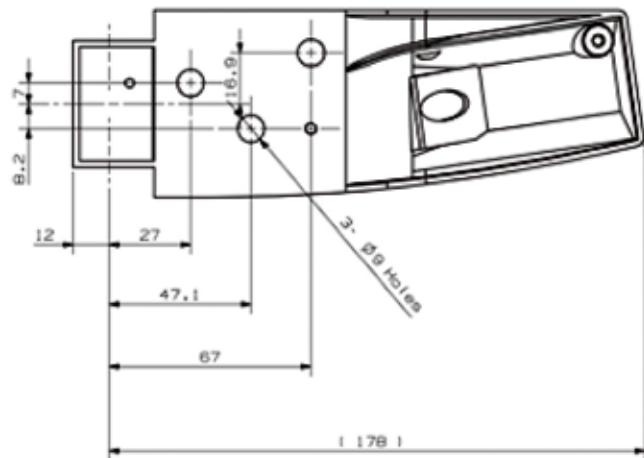
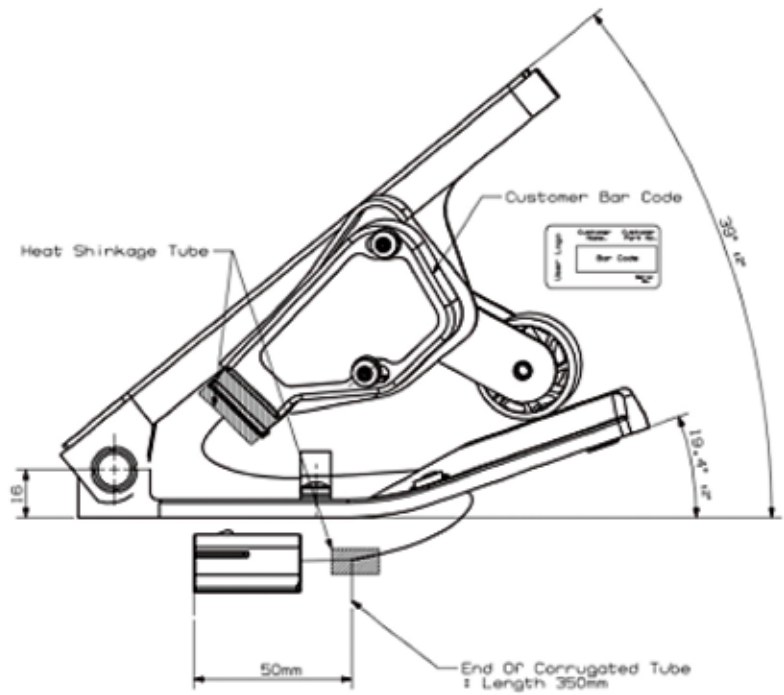
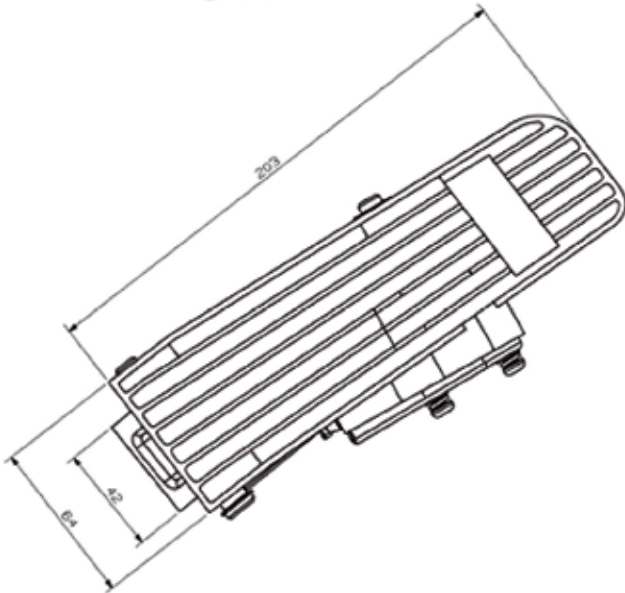

DRAWINGS

FLOOR-MOUNTED PEDAL (FMP) ANGLE 45° - DRAWING B



Technical Data

Operating temperature:	-40 °C to +85 °C
Protection:	IP 6k7k
Installation place:	Interior
Angle of actuation:	20° ± 2°

For additional information please refer to the technical drawing of the specific Part. NO.

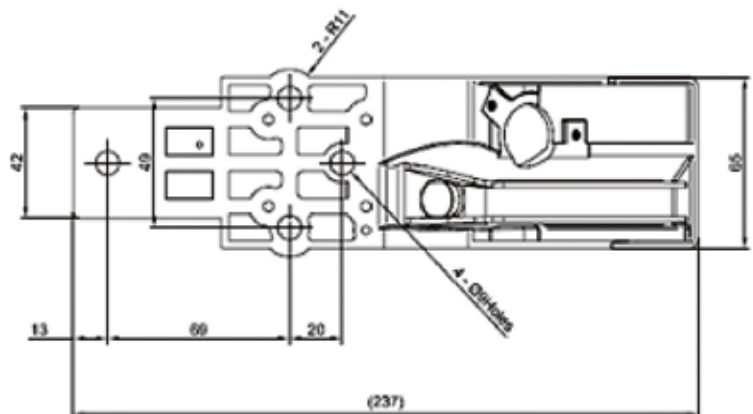
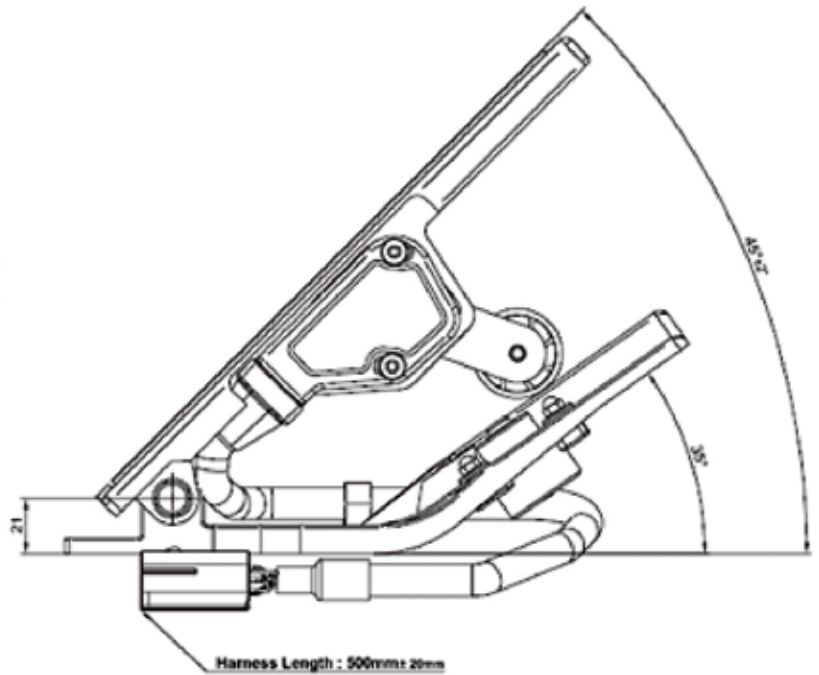
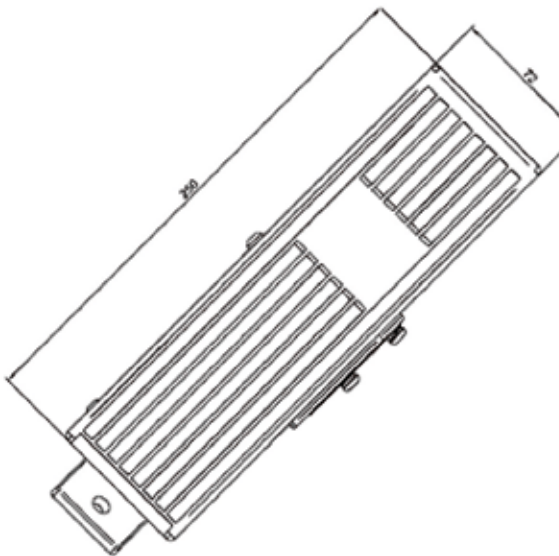

DRAWINGS

FLOOR-MOUNTED PEDAL (FMP) ANGLE 31° - DRAWING C



Technical Data	
Operating temperature:	-40 °C to +85 °C
Protection:	IP 6k7k
Installation place:	Interior
Angle of actuation:	20° ± 2°

For additional information please refer to the technical drawing of the specific Part. NO.

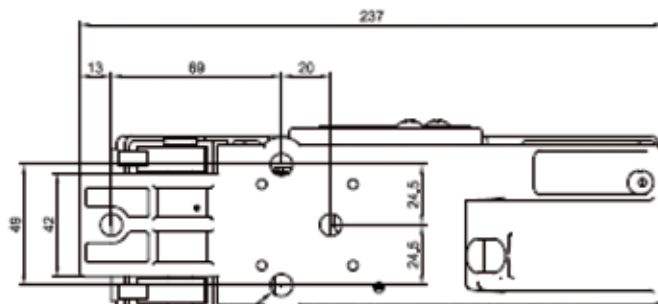
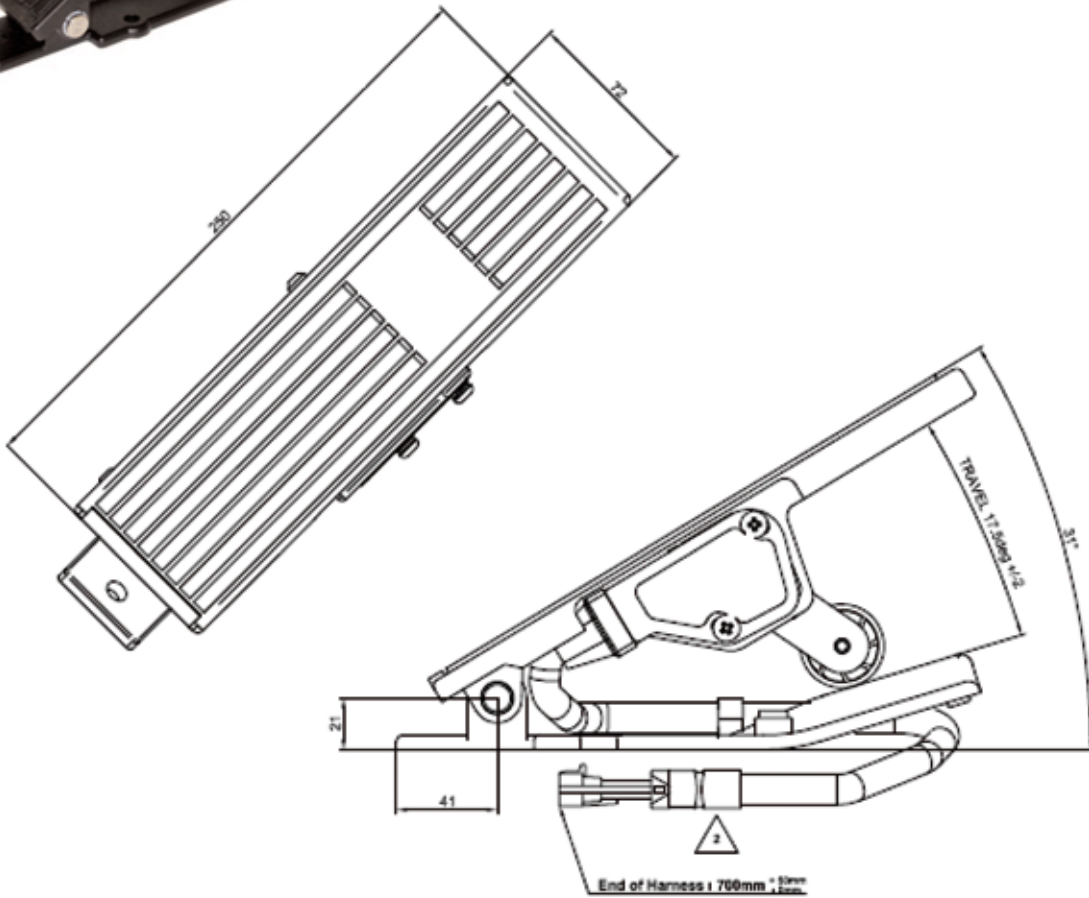

Accessories for vehicle wiring harness (not supplied as standard)

Part Number	Product	Description
		
X39-445-000-004	Kit C	Connector kit: AMP J Series, 6-pin
	Push-on connector	174262-2 (1x)
	Counter	174363-7 (1x)
	Contacts	
	Female	171662-5 (5x)
	Rubber plug	176886-2 (1x)
	Cable seal	172748-2 (5x)
X39-445-000-002	KitA	Connector kit: AMP J Series, 3-pin

NEW GENERATION - FLOOR PEDAL INTEGRATED

Output signals from pedals in this range are generated by contactless sensors. Twin coil springs integrated into the pedal provide added reliability for the pedal return mechanism. A special hysteresis element ensures the best possible experience for the driver when the pedal is operated. Various Hall sensors operate in conjunction with the integrated electronics to generate either analog or pulse width modulated (PWM) signals. The range of sensors is designed to suit every common type of engine interface. Sensors can also be adapted in accordance with customer requirements for specialist applications.

An optional kick-down signal can be generated using a special integrated mechanism. Kick-down is triggered when a specified upper threshold value is exceeded in the analog voltage range or an upper PWM signal threshold is exceeded (no additional signal inputs for engine controller required).

STANDARD TYPE



COMPACT TYPE



Description

Floor-mounted gas pedal for applications in commercial vehicles with electronically controlled engines.

The following variants are available:

- Standard type with 250 mm long foot plate and various pedal angles, available for series production: Q3, 2009.
- Compact type with 164 mm short foot plate and 25° pedal angle, available for series production: Q4, 2009.

Features

- Innovative, low-noise, compact design.
- Rugged construction, suitable for many different applications.
- Compatible with various engine interfaces.
- Contactless, non-wearing sensors.
- Integral twin return springs as per U.S. FMVSS-124.
- Extremely reliable.
- 6-pin connector (Delphi Packard, Type Metri Pack 150) built directly into sensor housing.
- Customer-specific footplates can be accommodated on request.
- Low noise pedal operation at no-load and full-load stops.
- Quiet kick-down.
- Glass fiber-reinforcement of plastic parts subject to mechanical load (PA66GF33).
- Choice of pedal angles (25°, 30°, 35°, 40°, or 45° for compact type, 30°, 35°, 40°, 45° or 50° for standard type).
- Angle of travel, 20°.

Supported engine interfaces (both pedal types)

Single channel analog with or without idle switch	Bosch EDC, MAN, Iveco, Perkins, Scania DEC 2, VM, MTU, John Deere, Detroit Diesel, Deutz, CAT Series 3000
Single channel analog with idle switch (changeover contacts)	Cummins Euro 3 engines, SAE J1843
Dual channel analog	Cummins Euro 4/5, Bosch engine management system (EDC) < 80 mA (< 10 mA standby)
Single PWM	Perkins, CAT
Dual PWM	Mercedes, MAN

NEW GENERATION - INTEGRATED PEDALS

Product	Sensor Type	Engine Type	Sensor 1	Sensor 2	IVS1	IVS2	Drw
FLOOR MOUNTED (FMP) PEDAL INTEGRATED ANGLE 25°							
A2C59513051	2x analog		0.7 - 3.0 [V]	3.0 - 0.7 [V]			D
FLOOR MOUNTED (FMP) PEDAL INTEGRATED ANGLE 40°							
A2C59514825	2x analog		0.5 - 4.5 [V]	4.5 - 0.5 [V]			F
FLOOR MOUNTED (FMP) PEDAL INTEGRATED ANGLE 35°							
A2C59514354	1x analog, 2x switches		0.6 - 4 [V]		1.15 [V] NC	1.15 [V] NO	G
A2C59514355	PWM		PWM 15% - 85% 500Hz				
FLOOR MOUNTED (FMP) PEDAL INTEGRATED ANGLE 45°							
A2C59514051	1x analog, 1x switch	Perkins	0.4 - 4.15 [V]		0.6 [V] NC		H
A2C59514344	1x analog, 1x switch		0.4 - 3 [V]		0.8 [V] NC		

DRAWINGS

FLOOR-MOUNTED PEDAL (FMP) PEDAL INTEGRATED ANGLE 25° (DRAWING D)

The floor mounted pedal consists of a base unit (nylon 66 %, GFK 30 %) with an already mounted pedal plate, that has to be fixed in the passenger compartment. For the simulation of the pedal forces, the path-dependent hysteresis and for the security two return springs are equipped. Depending on the design, the feedback of the pedal position takes place over a non-contact sender whereby the electronic coupling provides an analogue or a PWM signal. The idle position identification be made by an opto coupler or mechanically over a micro switch.

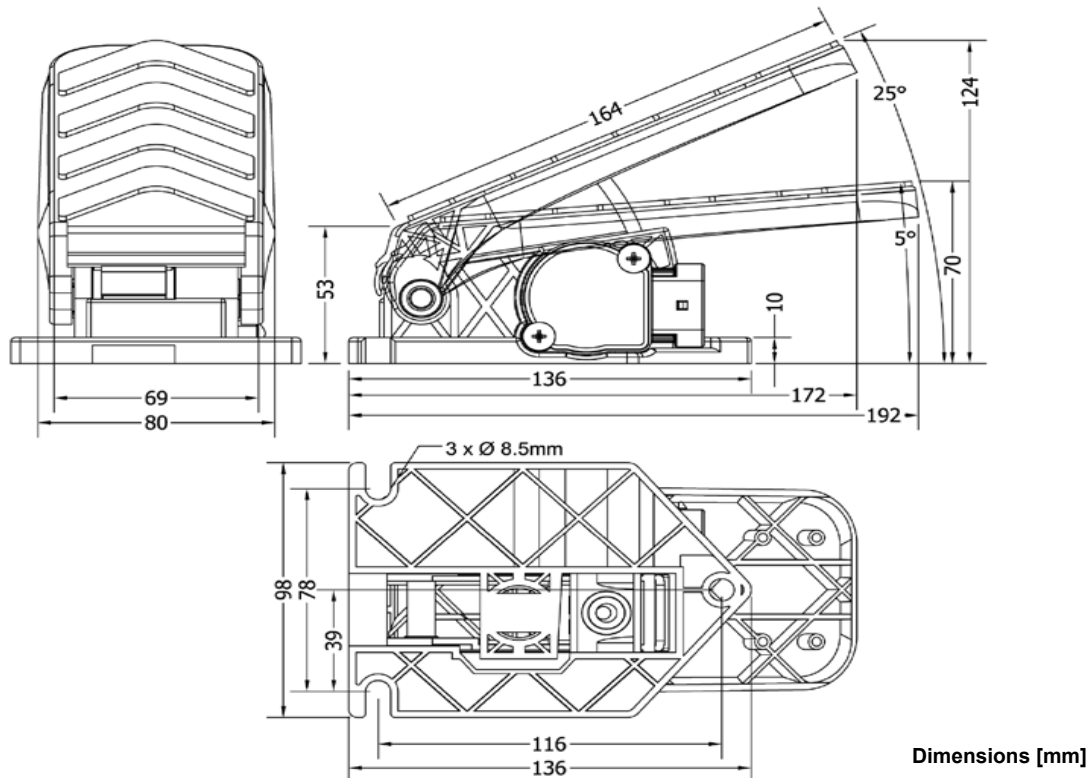

Accessories: Counter connector for vehicle harness (not supplied as standard)

Part Number	Product	Description
A2C59512245	Kit D	Connector assembly: Delphi Metri Pack 150, 6-pole
	Female connector plug assembly	12066317 (1x)
	Female tin plated terminal	12103881 (6x)

DRAWINGS

FLOOR-MOUNTED (FMP) PEDAL INTEGRATED ANGLE 40° (DRAWING F)

Technical Data	
Voltage supply 5 V ± 2 % by electronic controller	
Operating temperature:	-40 °C to +85 °C
Protection:	IP 6k7k
Installation place:	Interior
Angle of actuation:	20° ± 2°

For additional information please refer to the technical drawing of the specific Part. NO.

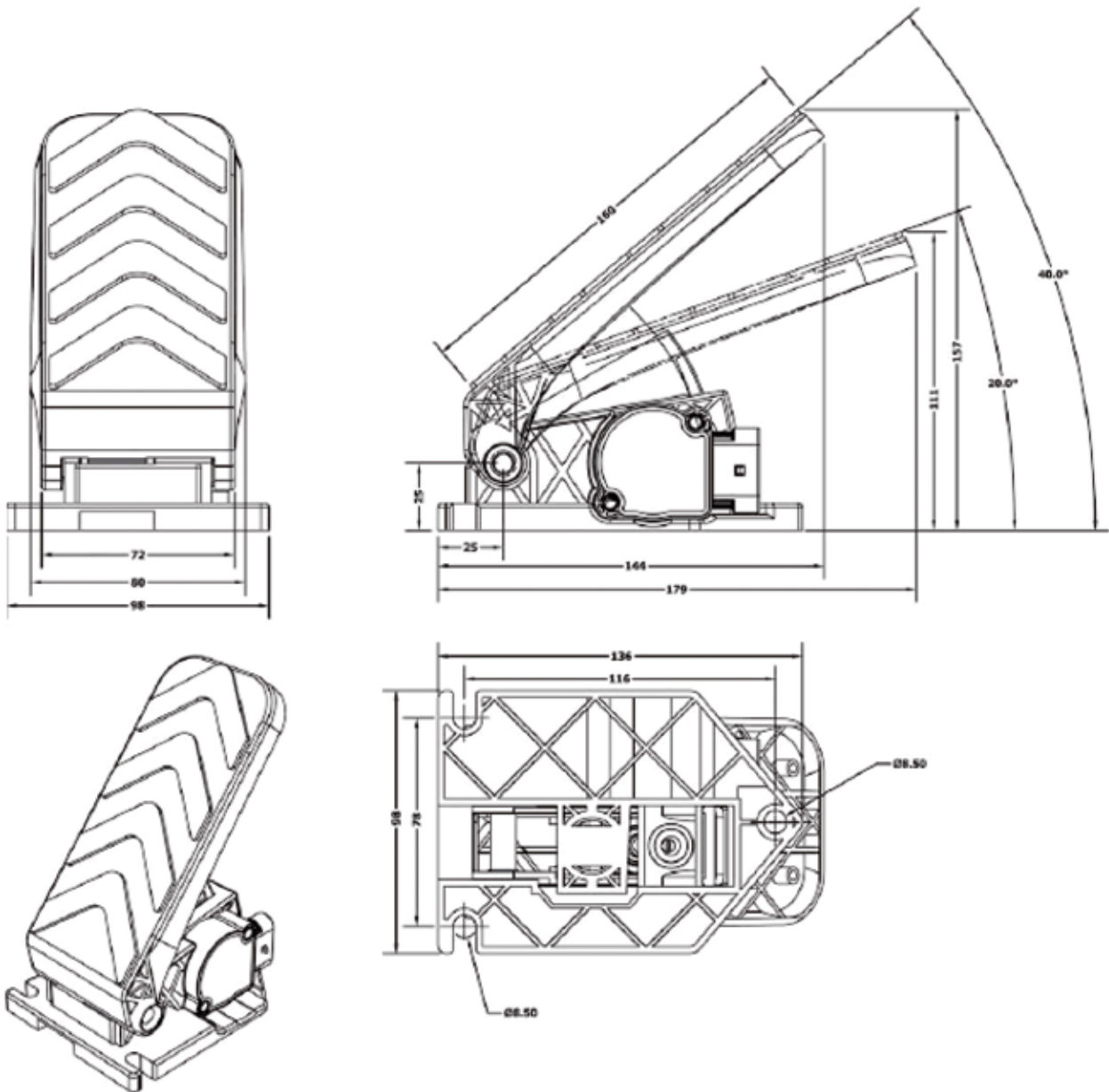

DRAWINGS

FLOOR-MOUNTED (FMP) PEDAL INTEGRATED ANGLE 35° (DRAWING G)

Technical Data	
Voltage supply 5 V ± 2 % by electronic controller	
Operating temperature:	-40 °C to +85 °C
Protection:	IP 6k7k
Installation place:	Interior
Angle of actuation:	20° ± 2°

For additional information please refer to the technical drawing of the specific Part. NO.

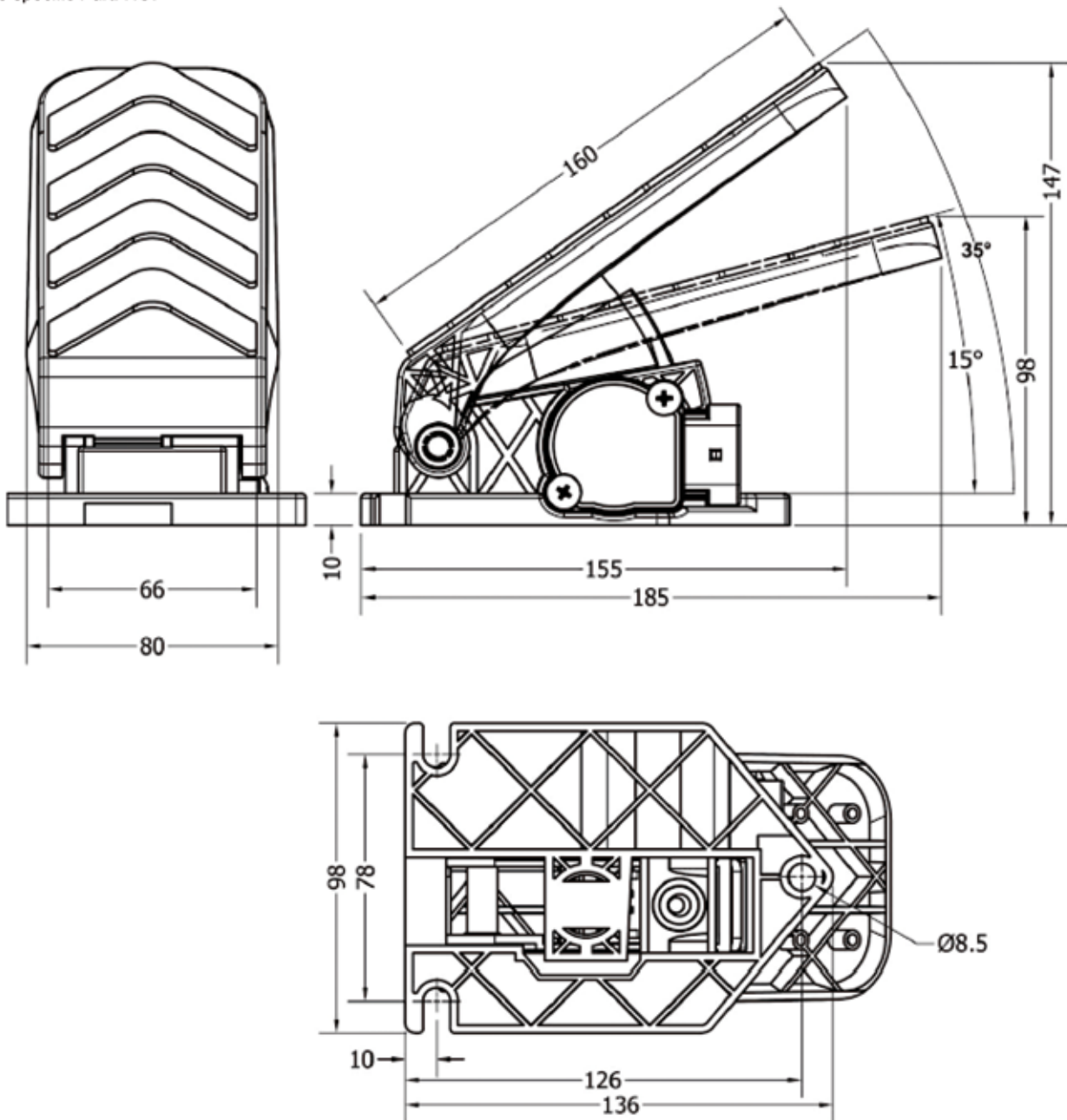

DRAWINGS

FLOOR-MOUNTED (FMP) PEDAL INTEGRATED ANGLE 45° (DRAWING H)

The floor mounted pedal consists of a base unit (nylon 66 %, GFK 30 %) with an already mounted pedal plate, that has to be fixed in the passenger compartment. For the simulation of the pedal forces, the path-dependent hysteresis and for the security two return springs are equipped. Depending on the design, the feedback of the pedal position takes place over a non-contact sender whereby the electronic coupling provides an analogue or a PWM signal. The idle position identification be made by an opto coupler or mechanically over a micro switch.

Technical Data	
Voltage supply 5 V ± 2 % by electronic controller	
Operating temperature:	-40 °C to +85 °C
Protection:	IP 6k7k
Installation place:	Interior
Angle of actuation:	20° ± 2°

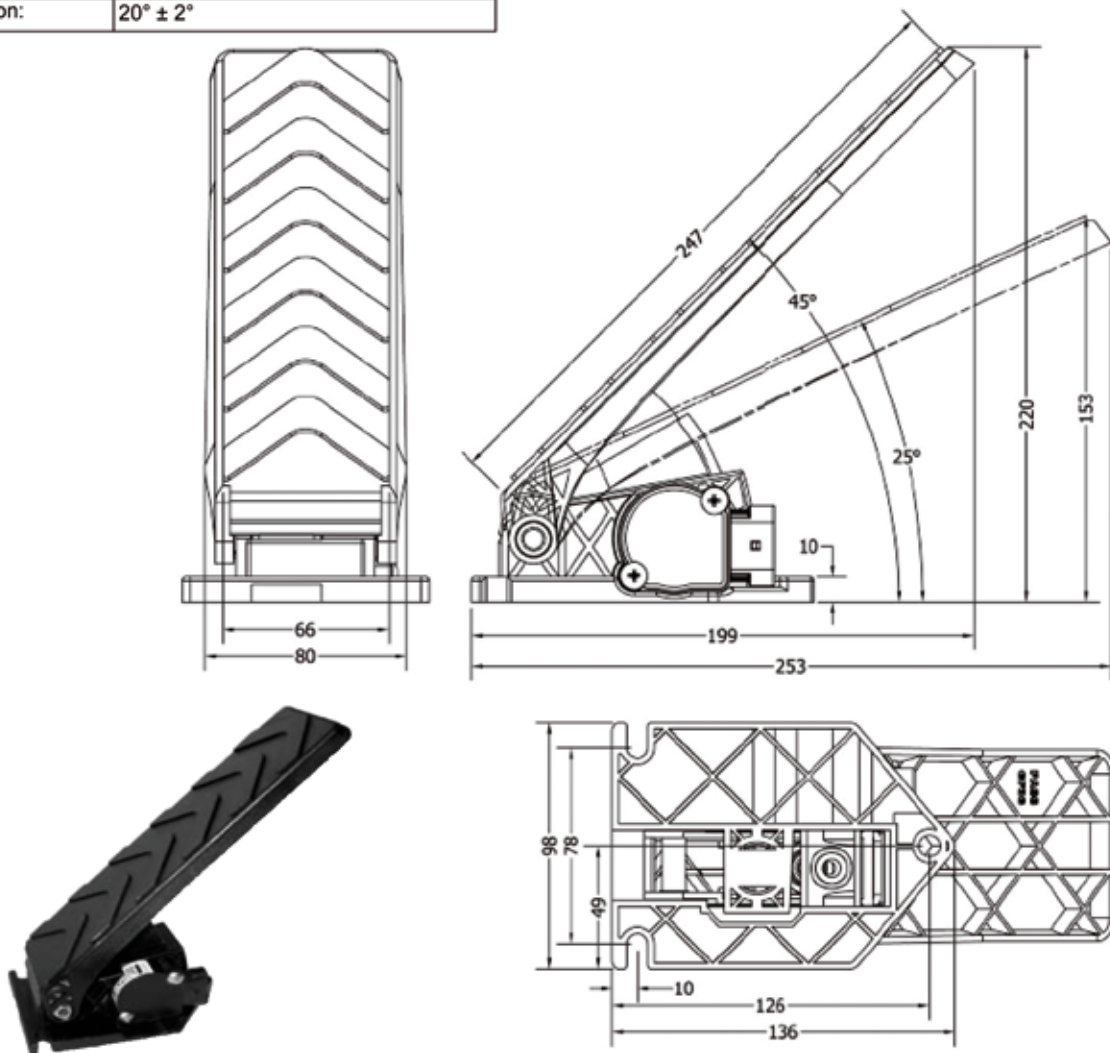

Accessories: Counter connector for vehicle harness (not supplied as standard)

Part Number	Product	Description
		
A2C59512245	Kit D	Connector assembly: Delphi Metri Pack 150, 6-pole
	Female connector plug assembly	12066317 (1x)
	Female tin plated terminal	12103881 (6x)

5.1.2 Suspended Pedal

STEEL LEVER

The suspended pedal consists of a base unit (nylon 66%, GFK 30%) and a pre-fitted pedal lever (stainless steel, SUS 304, polished). Twin return springs are used to replicate the pedal forces and direction-dependent hysteresis and to provide added safety. Pedal position feedback is provided by a contactless sensor connected to either an analog or PWM signal circuit, depending on the variant. The no-load state can be detected either by an optocoupler or mechanically via a microswitch.

Product	Sensor Type	Engine Type	Sensor 1	Sensor 2	IVS1	IVS2	Drw
SUSPENDE PEDAL (SPP) METAL ARM							
A2C59515562	1x analog, 2x switches		0.45 - 3.65 [V]		0.6 [V] NC	0.71 [V] NO	I
A2C59513861	PWM		PWM 7.5% - 92.5%				
A2C59515518	1x analog, 2x switches		0.45 - 3.65 [V]		0.6 [V] NC	0.71 [V] NO	
A2C59515545	2x analog, 2x switches		0.5 - 4.5 [V]	4.5 - 0.5 [V]	0.7 [V] NC	0.8 [V] NO	
X10-445-110-002	1x analog, 1x switches	Perkins, Caterpillar	0.4 - 4.15 [V]		0.6 [V] NC		
SUSPENDE PEDAL (SPP) MODIFIED METAL ARM							
A2C59515508	1x analog, 1x switch		0.4 - 4.15 [V]			0.8 [V] NO	L
A2C59515524	1x analog, 1x switch		0,2 - 4,5 [V]			0,2 [V] NO	L1

DRAWINGS

SUSPENDE PEDAL (SSP) METAL ARM (DRAWING I)

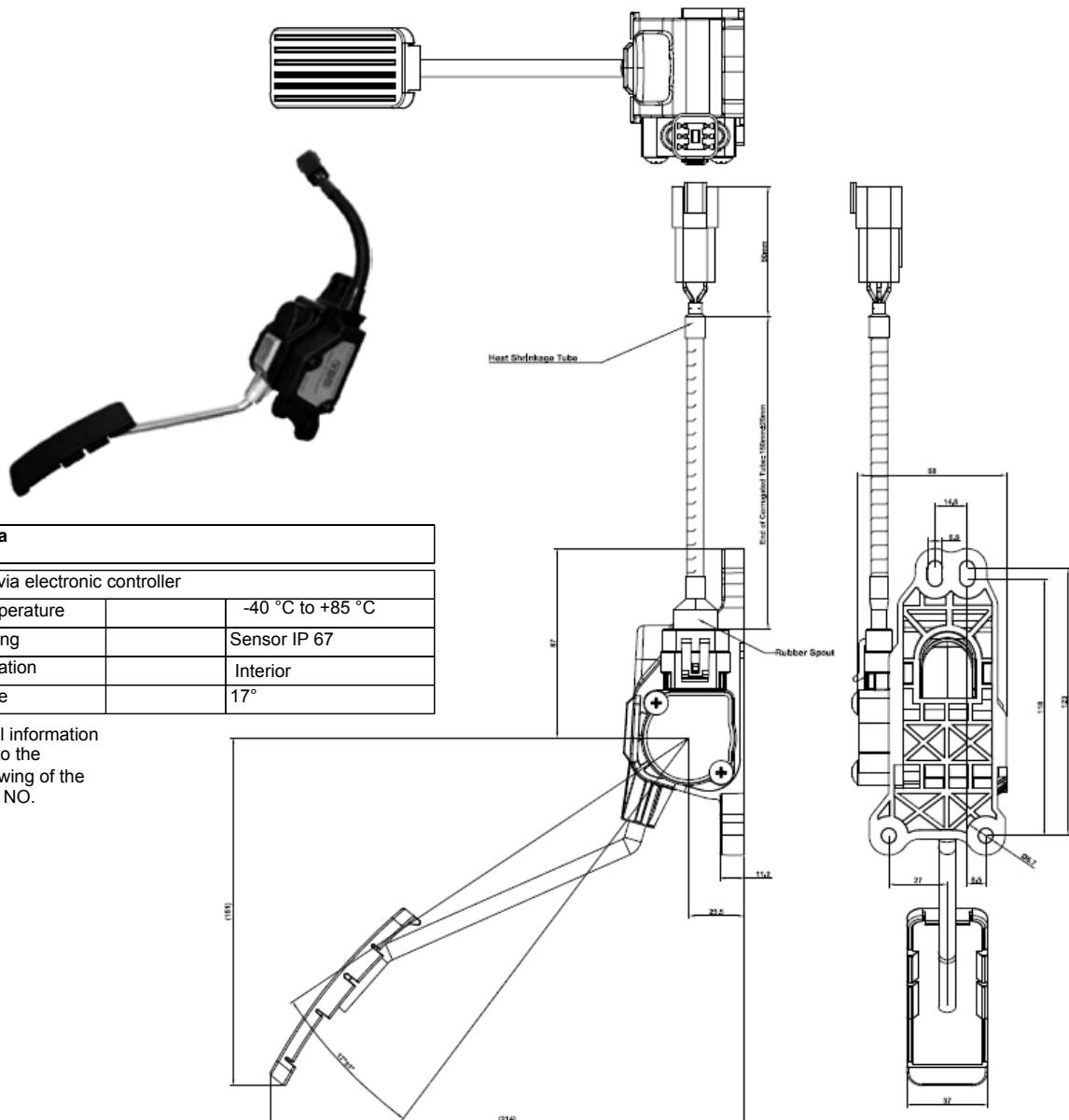

Technical data	
Power supply via electronic controller	
Operating temperature	-40 °C to +85 °C
Protection: rating	Sensor IP 67
Installation location	Interior
Actuation angle	17°

For additional information please refer to the technical drawing of the specific Part. NO.

DRAWINGS

SUSPENDED PEDAL (SSP) MODIFIED METAL ARM (DRAWING L)

Technical data		
Power supply via electronic controller		
Operating temperature		-40 °C to +85 °C
Protection: rating		Sensor IP 67
Installation location		Interior
Actuation angle		17°

For additional information please refer to the technical drawing of the specific Part. NO.

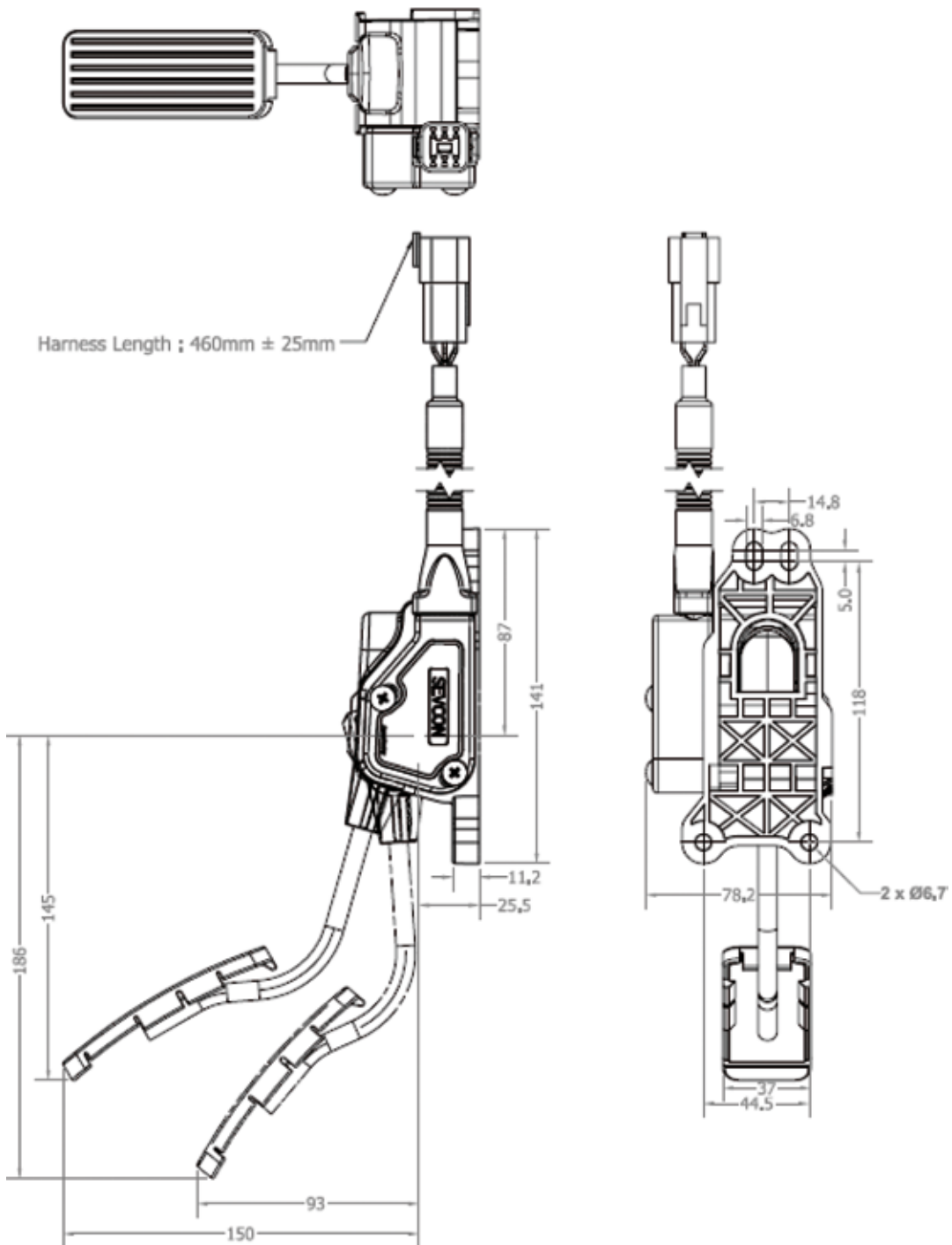

DRAWINGS

SUSPENDED PEDAL (SSP) MODIFIED METAL ARM (DRAWING L1)

Technical data		
Power supply via electronic controller		
Operating temperature		-40 °C to +85 °C
Protection: rating		Sensor IP 67
Installation location		Interior
Actuation angle		17°

For additional information please refer to the technical drawing of the specific Part. NO.

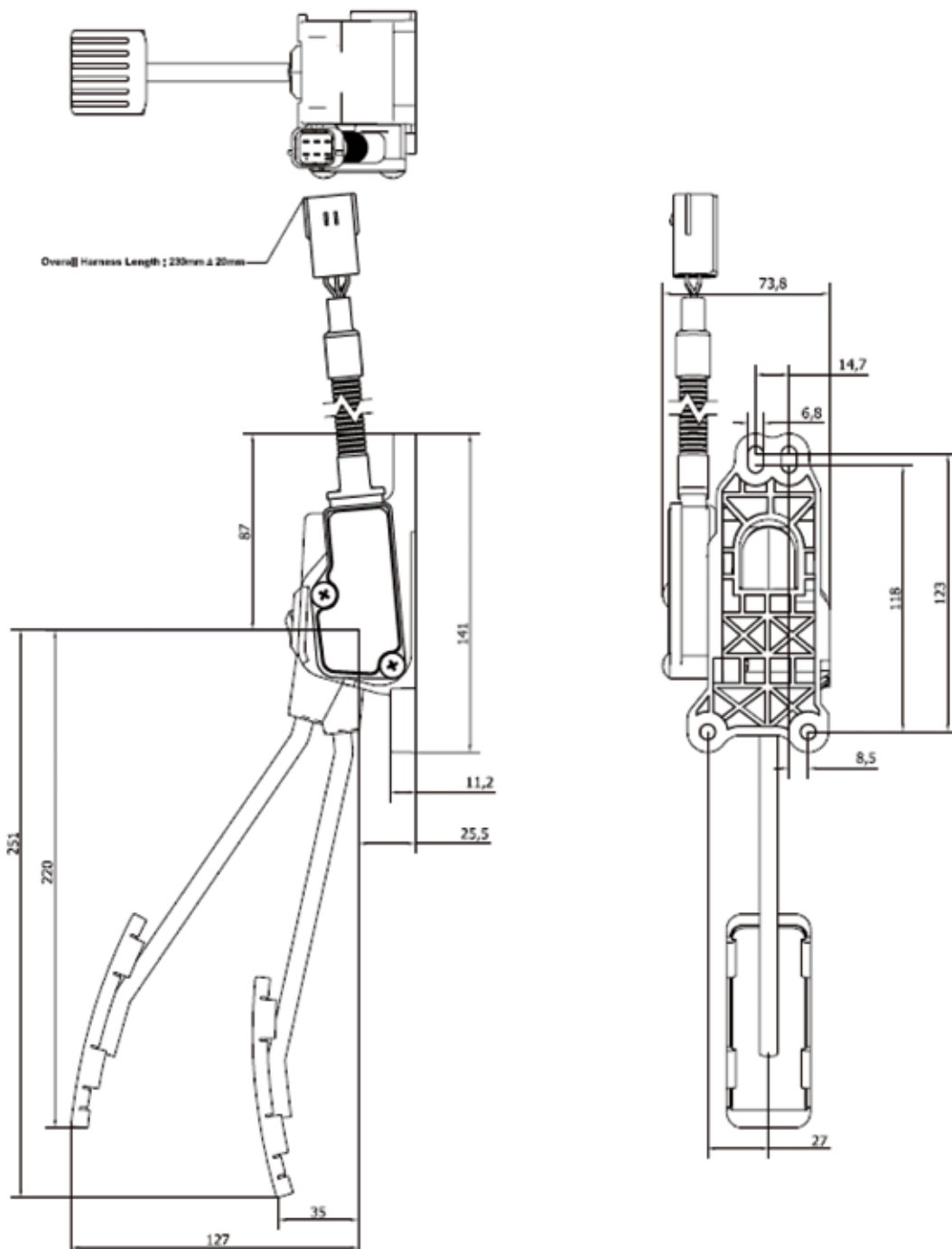

PLASTIC LEVER

The suspended pedal consists of a base unit and a pre-fitted pedal lever (66% nylon, 30% GFRP). Twin return springs are used to replicate the pedal forces and direction-dependent hysteresis and to provide added safety. Pedal position feedback is provided by a contactless sensor connected to either an analog or PWM signal circuit, depending on the variant. The no-load state can be detected either by an optocoupler or mechanically via a microswitch, according to the application.

Product	Sensor Type	Engine Type	Sensor 1	Sensor 2	IVS1	IVS2	Drw
SUSPENDED PEDALS (SPP) PLASTIC ARM							
A2C59512134	1x analog, 2x switches		0.45 - 3.65 [V]		0.6 [V] NC	0.71 [V] NO	M

SUSPENDED PEDAL (SSP) PLASTIC ARM (DRAWING M)

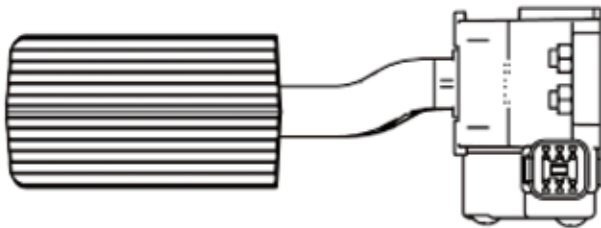

Technical data

Power supply via electronic controller

Operating temperature	-40 °C to +85 °C
Protection: rating	Sensor IP 67
Installation location	Passenger compartment
Actuation angle	20° ± 1°

For additional information please refer to the technical drawing of the specific Part. NO.

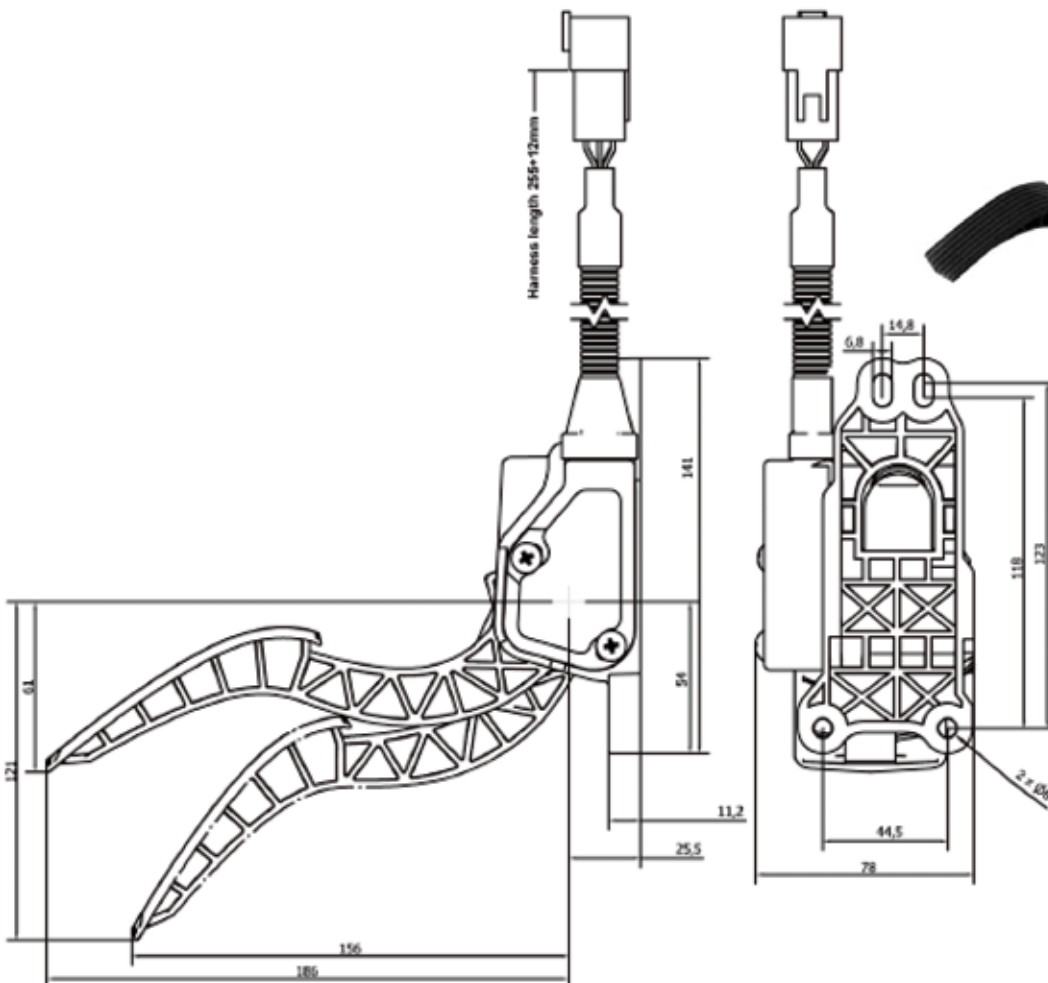

NEW GENERATION - INTEGRATED SUSPENDED PEDALS

Suspended accelerator pedal for use in commercial vehicles with electronically controlled engines for robust and save operation. Two different designs with different pedal arm lengths are available. The electrical signals of the pedal position are provided by a contactless sensor. Two build-in return springs are used for safety and resetting the pedal position. A special designed hysteresis element provides an excellent driving comfort. Different contactless hall sensor electronics provide analogue- or pulse width modulated (PWM) signals. The sensor is designed to manage all common used engine interfaces. For special applications the sensor can be designed to meet the customer requirements. An optional kickdown feeling is realized by using a special mechanism. In this case the upper analogue voltage or PWM value of the signal span is used for kickdown indication (no need of an additional signal input in the engine control unit).

Product	Sensor Type	Engine Type	Sensor 1	Sensor 2	IVS1	IVS2	Drw
SUSPENDED PEDAL (SPP) INTEGRATED PLASTIC SHORT ARM							
A2C59514646	1x analog, 1x switch		0.5 - 4.5 [V]		0.75 [V] NO		J
A2C59513366	2x analog		1.1 - 4.2 [V]	0.55 - 2.1 [V]			
A2C59507638	1x analog, 1x switch		0.5 - 4.5 [V]		0.7 [V] NC		
A2C59515441	2x analog		0.75 - 4.45 [V]	0.375 - 2.275 [V]			
A2C59512909	2x analog		0.75 - 4.2 [V]	0.375 - 2.1 [V]			
A2C59513863	Dual Cross PWM	Mercedes	PWM 82% - 41% 200Hz	PWM 18% - 49% 200Hz			
SUSPENDED PEDAL (SPP) INTEGRATED PLASTIC EXTENDED ARM							
A2C59515205	2x analog		0.5 - 4.5 [V]	4.5 - 0.5 [V]			K
A2C59513641	2x analog		0.5 - 4.5 [V]	4.5 - 0.5 [V]			
A2C59512986	Dual Cross PWM	Mercedes	PWM 82% - 41% 200Hz	PWM 18% - 49% 200Hz			

STANDARD TYPE



VARIANT WITH EXTENDED PEDAL ARM



Features

- Innovative, low-noise, compact design.
- Rugged construction, suitable for many different applications.
- Compatible with various engine interfaces.
- Contactless, non-wearing sensors.
- Integral twin return springs as per U.S. FMVSS-124.
- Extremely reliable.
- 6-pin connector (Delphi Packard, Type Metri Pack 150) built directly into sensor housing.
- Customer-specific footplates can be accommodated on request.
- Low noise pedal operation at no-load and full-load stops.
- Quiet kick-down.
- Glass fiber-reinforcement of plastic parts subject to mechanical load (PA66GF33).
- Angle of travel, 18.5.

DRAWINGS

INTEGRATED SUSPENDED PEDAL WITH PLASTIC SHORT ARM (DRAWING J)

The suspended pedal consists of a base unit (nylon 66 %, GFK 30 %) with an already mounted pedal arm, that has to be fixed in the passenger compartment. For the simulation of the pedal forces, the path-dependent hysteresis and for the security two return springs are equipped. Depending on the design, the feedback of the pedal position takes place over a non-contact sender where by the electronic coupling provides an analogue or a PWM signal. The idle position identification be made by an opto coupler or mechanically over a micro switch.

Technical Data	
Voltage supply 5 V \pm 2 % by electronic controller	
Operating temperature:	-40 °C to +85 °C
Protection:	IP 6k7k
Installation place:	Interior

For additional informatio
the specific Part. NO.

Dimensions [mm]

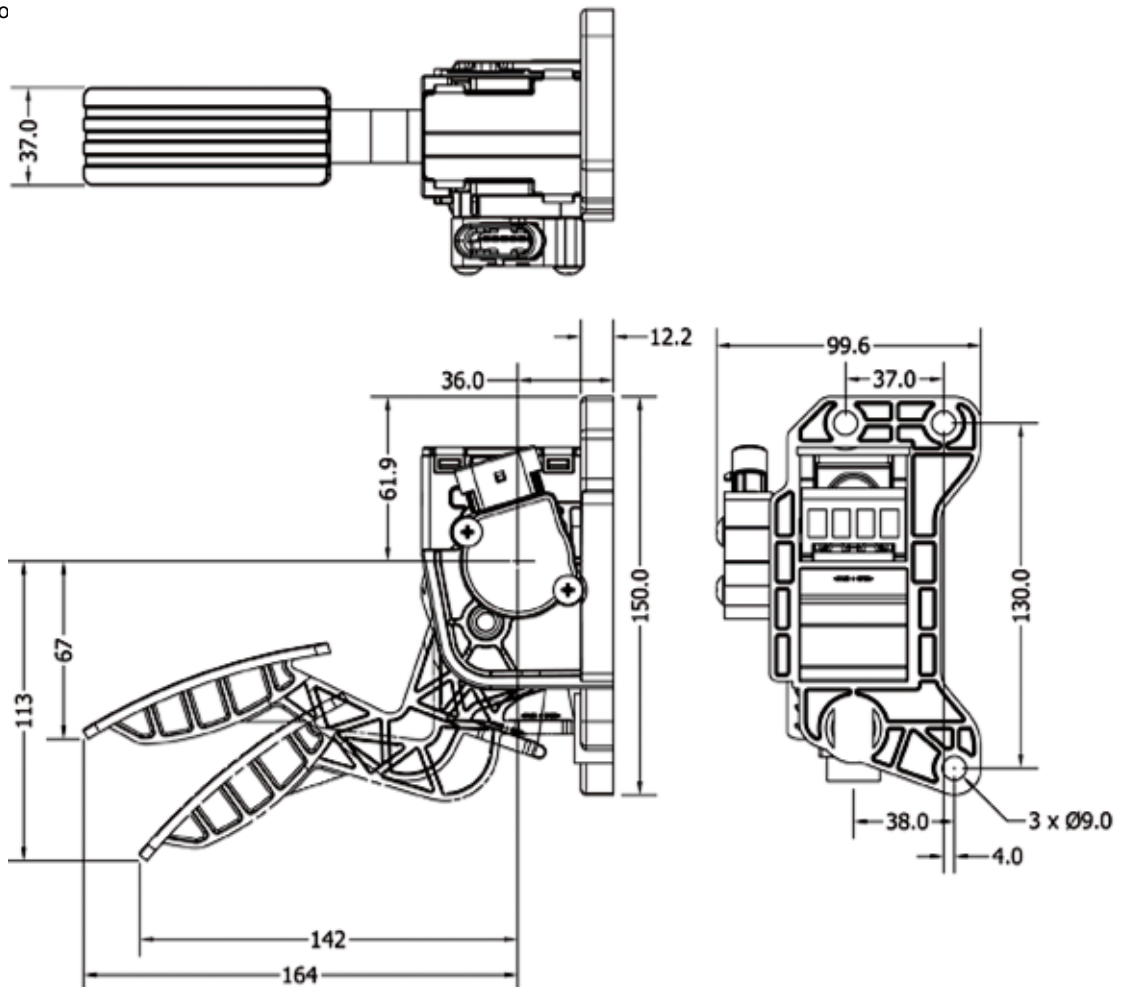

Counter connector for vehicle harness (not part of the delivery)

Part Number	Product	Description
		
A2C59512245	•Kit D	Connector assembly: Delphi Metri Pack 150, 6-pole
	Female connector plug assembly	12066317 (1x)
	Female tin plated terminal	12103881 (6x)

DRAWINGS

INTEGRATED SUSPENDED PEDAL WITH PLASTIC EXTENDED ARM (DRAWING K)

Dimensions [mm]

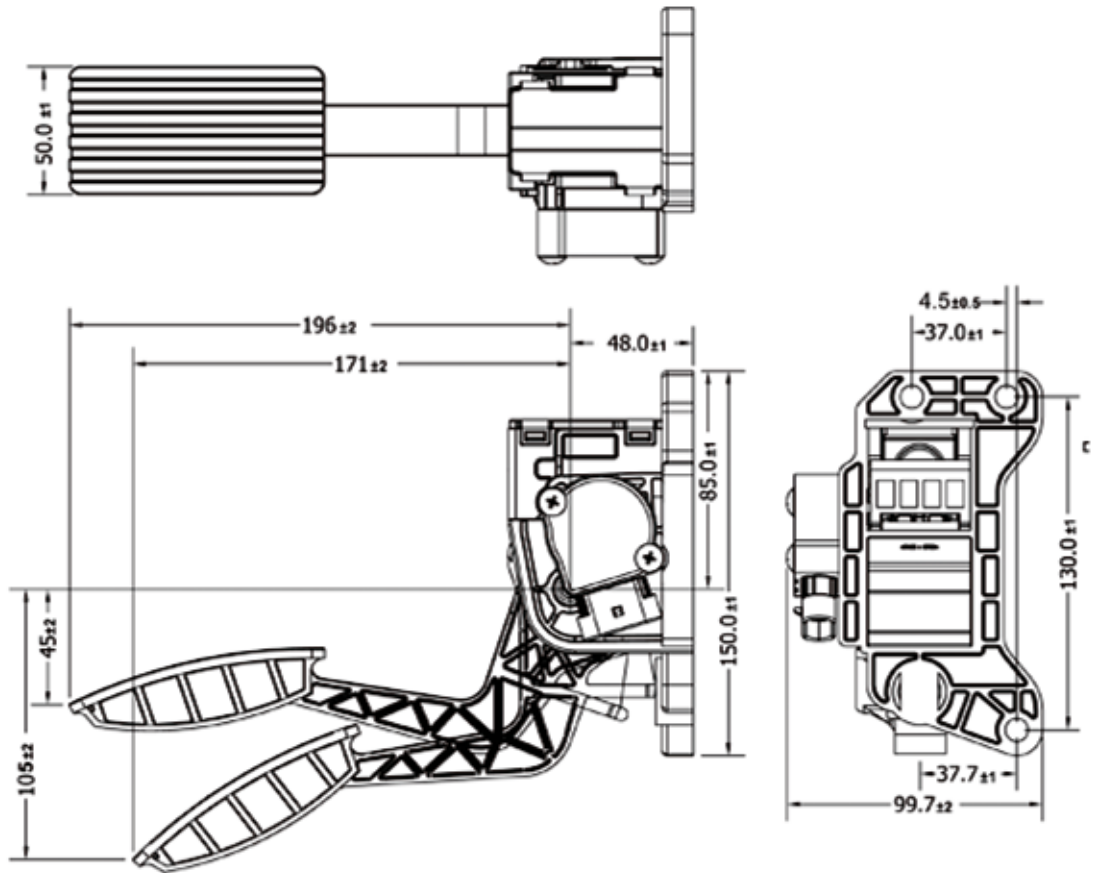

Technical Data	
Voltage supply 5 V ± 2 % by electronic controller	
Operating temperature:	-40 °C to +85 °C
Protection:	IP 6k7k
Installation place:	Interior

For additional information please refer to the technical drawing of the specific Part. NO.

Counter connector for vehicle harness (not part of the delivery)

Part Number	Product	Description
A2C59512245	Kit D	Connector assembly: Delphi Metri Pack 150, 6-pole
	Female connector plug assembly	12066317 (1x)
	Female tin plated terminal	12103881 (6x)



5.1.3 Customer-Specific Solutions

Tractor pedal

Description

This system is designed for applications that demand a rugged and reliable pedal. The pedal features internal, dual-redundant return springs to enable a safe, reliable return action. Information about the position of the pedal is transmitted via a contactless Hall sensor. A range of sensor outputs is available, providing single or dual channel, analog or PWM signals.

Features

- Robust and versatile.
- Range of interface options.
- Contactless, non-wearing sensor.
- Extremely reliable.

Concept

Rugged mechanical parts allow customers to enjoy years of trouble-free service. The bearing for the pedal lever is based on non-wearing, synthetic materials. Angular movement is safely restricted to the desired range, even in tough applications, thanks to sturdy, firmly attached limit stops. Along with the electronic position signal determined by the Hall sensor signals, this makes that the correct idle and full-load positions are always maintained. Carefully specified friction elements provide continuous adjustment across the full adjustment range, which is essential for both safety and drivability.

The sensor is connected directly to the vehicle wiring harness via a 6-pin connector (Delphi Packard Metri Pack 150, IP 67).



Tractor pedal



Dimensions [mm]

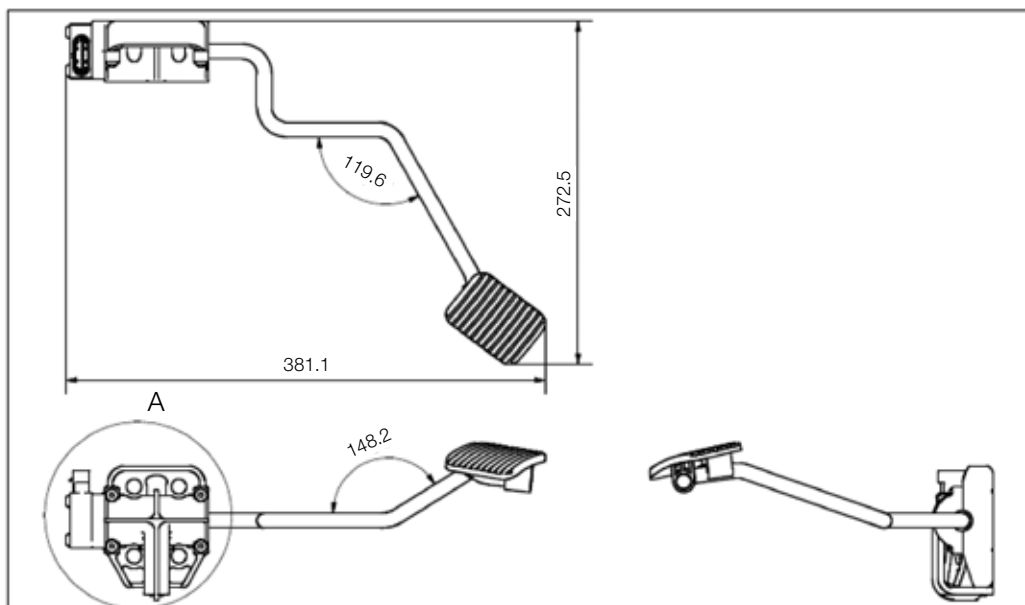
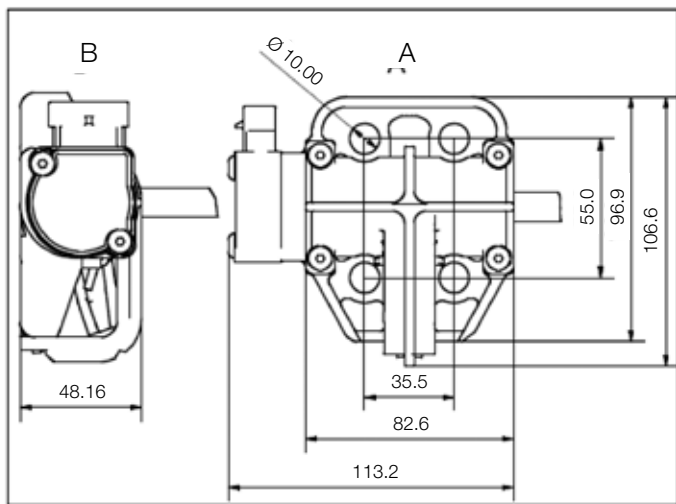

* The illustration shows one possible design option. The pedal arm geometry can be adapted to meet specific customer requirements.

5.2 Hand-Operated Accelerators and Pedal Sensors

HAND-OPERATED ACCELERATORS

Hand-operated accelerators for mounting in cab. Rugged housing (aluminum) for safe operation of the accelerators. No self-actuating return mechanism. Lever position feedback is provided by a contactless sensor connected to either an analog or PWM signal circuit, depending on the variant. The no-load state is detected either by an optocoupler or mechanically via a micro-switch, according to the version.

Product	Sensor Type	Engine Type	Sensor 1	Sensor 2	IVS1	IVS2	Drw
HAND OPERATED ACCELERATORS							
X10-445-650-002	1x analog, 1x switch	Perkins, Caterpillar	0.4 - 4.15 [V]		0.6 [V] NC		
X10-445-650-004	1x analog, 2x switch	VW, MTU, John Deere, Deutz, Iveco, Isotta Fraschini	0.4 - 4.0 [V]		0.6 [V] NC	0.71 [V] NO	○

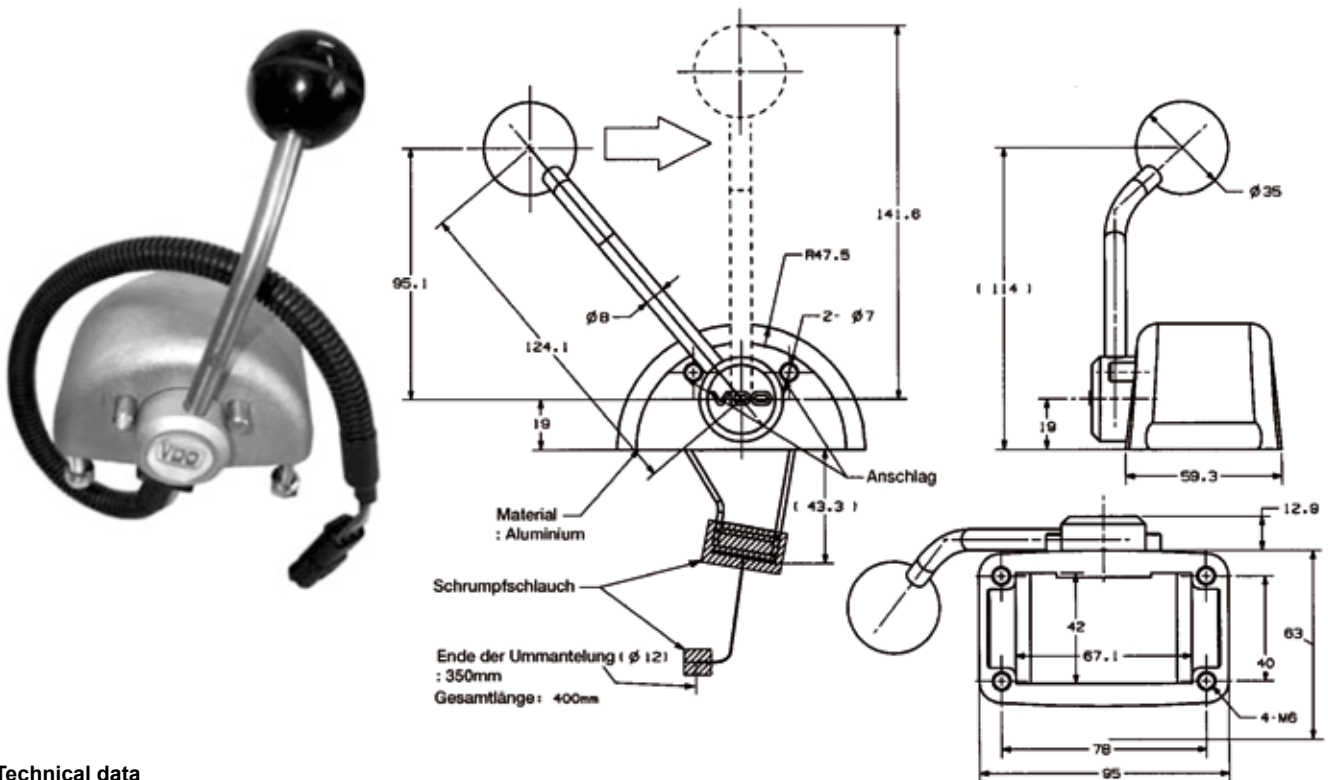

Technical data

Power supply via electronic controller	
Operating temperature	-40 °C to +85 °C
Protection rating	Sensor IP 67
Installation location	Passenger compartment
Actuation angle	92°

For additional information please refer to the technical drawing of the specific Part. NO.

Accessories for vehicle wiring harness (not supplied as standard)

Part Number	Product	Description
	 PLUG	
X39-445-000-004	Kit C	Connector kit: AMP J Series, 6-pin
	Push-on connector	174262-2 (1x)
	Counter	174363-7 (1x)
	Contacts	
	Female	171662-5 (5x)
	Rubber plug	176886-2 (1x)
	Cable seal	172748-2 (5x)

SENSOR ASSEMBLED WITH LEVER

Product	Sensor Type	Engine Type	Sensor 1	Sensor 2	IVS1	IVS2	Drw
SENSOR ASSEMBLED WITH LEVER							
A2C59516925	2x analog		0.5 - 4.5 [V]	0.5 - 4.5 [V]			N
A2C59515502	2x analog		0.5 - 4.5 [V]	4.5 - 0.5 [V]			
A2C59513193	2x analog		0.75 - 3.93 [V]	0.375 - 1.965 [V]			
A2C59513591	PWM	Caterpillar	PWM 15% - 85% 500Hz				
A2C59515079	1x analog, 1x switch		0.5 - 4.5 [V]		1.15 [V] NC		
A2C59516775	1x analog, 1x switch	Perkins	0,4 - 4 [V]		0,6 [V] NC		

Dimensions [mm]

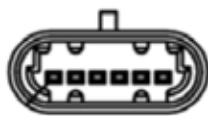
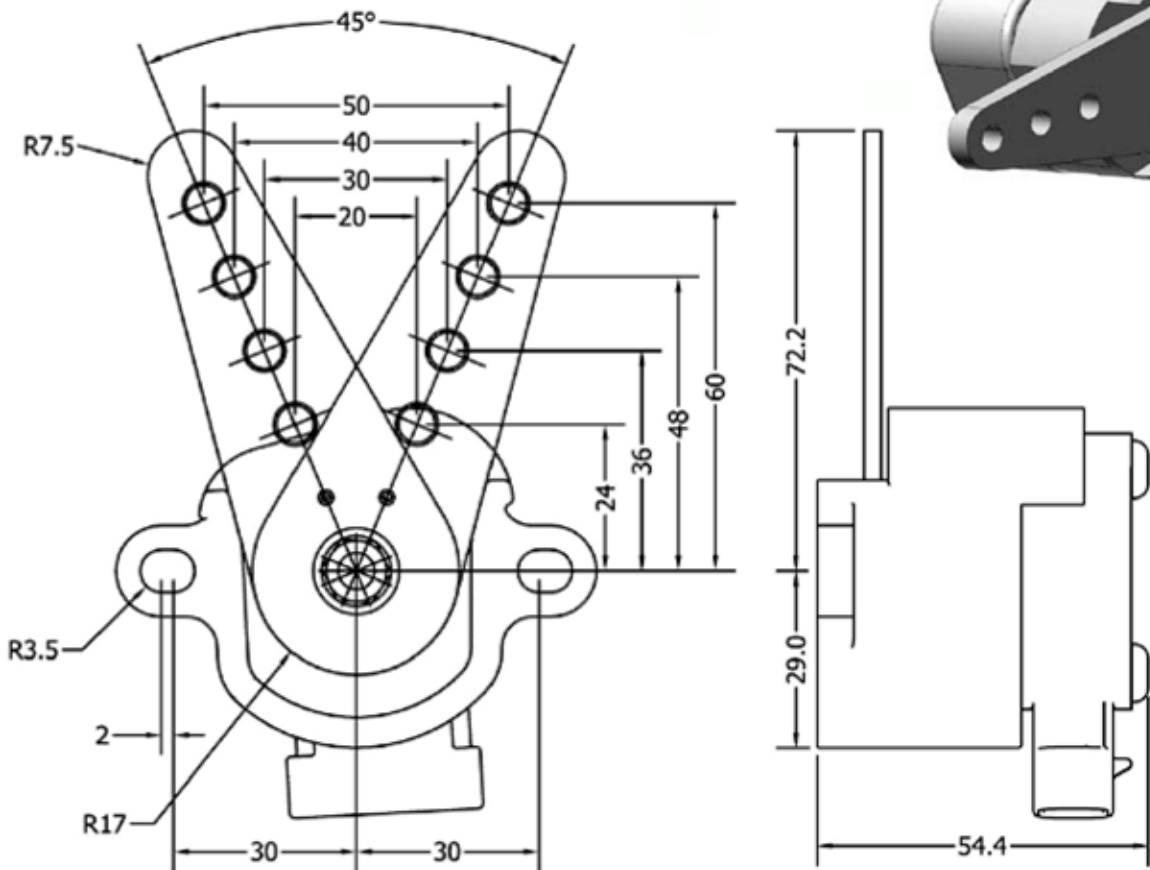

Technical data	
Power supply via electronic controller (+5 VDC ± 2 %)	
Operating temperature	-40 °C to +85 °C
Protection rating	Sensor IP 67
Installation location	Passenger compartment

For additional information please refer to the technical drawing of the specific Part. NO.

Accessories for vehicle wiring harness (not supplied as standard)

Part Number	Product	Description
A2C59512245	Kit D	Delphi Metri Pack 150
	Connector	12066317 (1x)
	Terminal	12103881 (6x)

EXTERNAL ACCELERATOR ASSEMBLIES*

ACCELERATION SENSOR ASSEMBLY (AA1) WITH SENSOR HS1

For adaptation of accelerator pedal sensors to existing accelerator pedals provided by customers. Robust and save linkage of accelerator pedals. Standard part and various designs available on customer request. Comprises two return springs.



Part No. A2C59515529

Technical data	
Power supply: (+12 VDC ± 2 %)	
Operating temperature	-40 °C to +85 °C
Protection rating	Sensor IP 67
Installation location	Passenger compartment
Output Signal	0.4 – 5.15V
Idle Switch	0.7 V, Normally Open

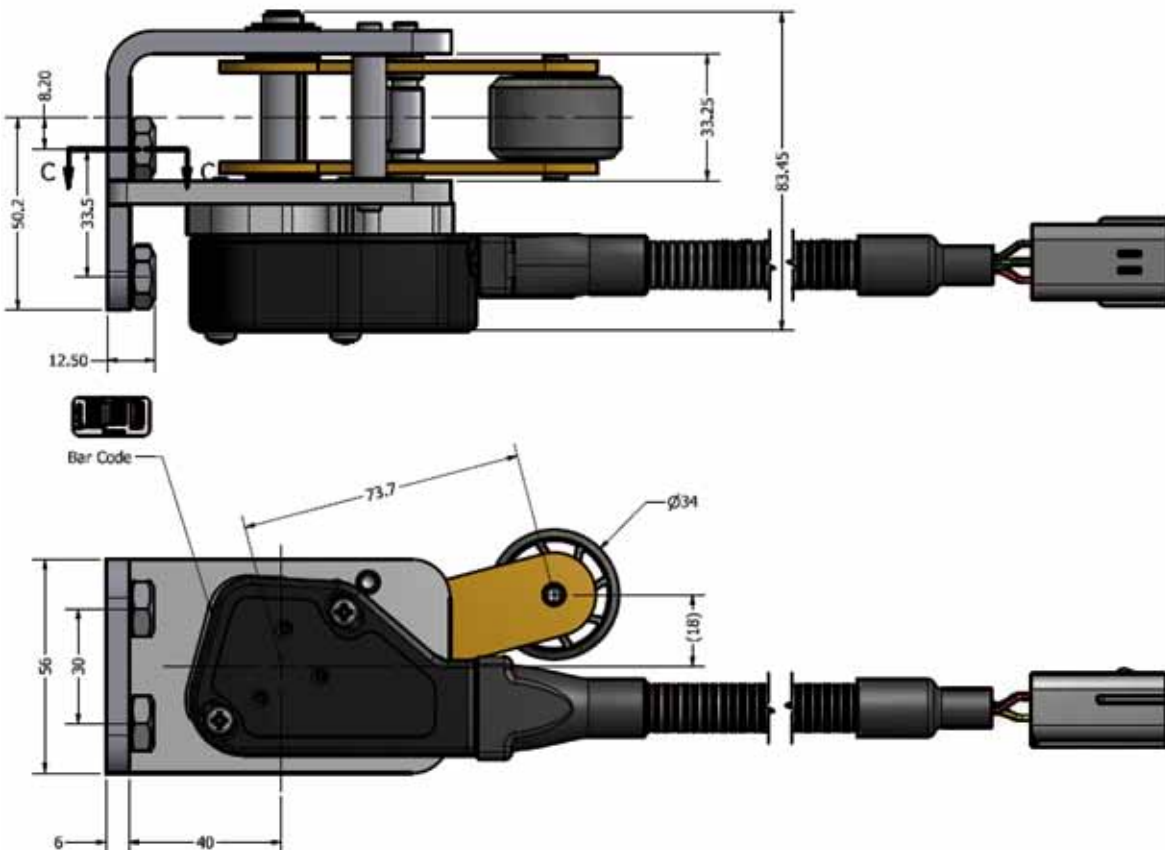

** Only available for series production application on request



6. Screen Washer Systems

CONTAINER SYSTEM, 4 LITERS

Comprises:

- 1 container, 4 l
- 1 container cap
- 1 bracket for container
- 1 filter
- 1 Mono Pump or Dual Pump

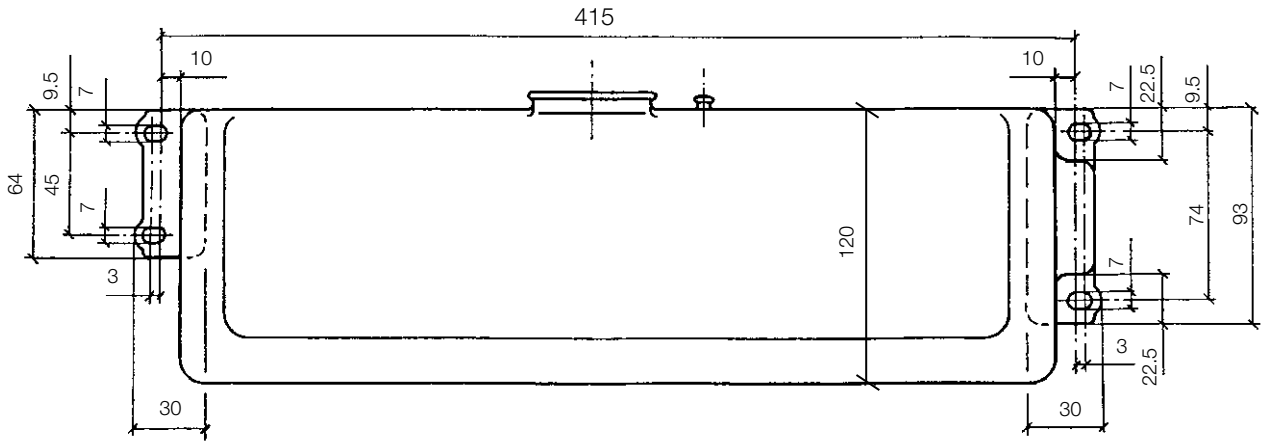
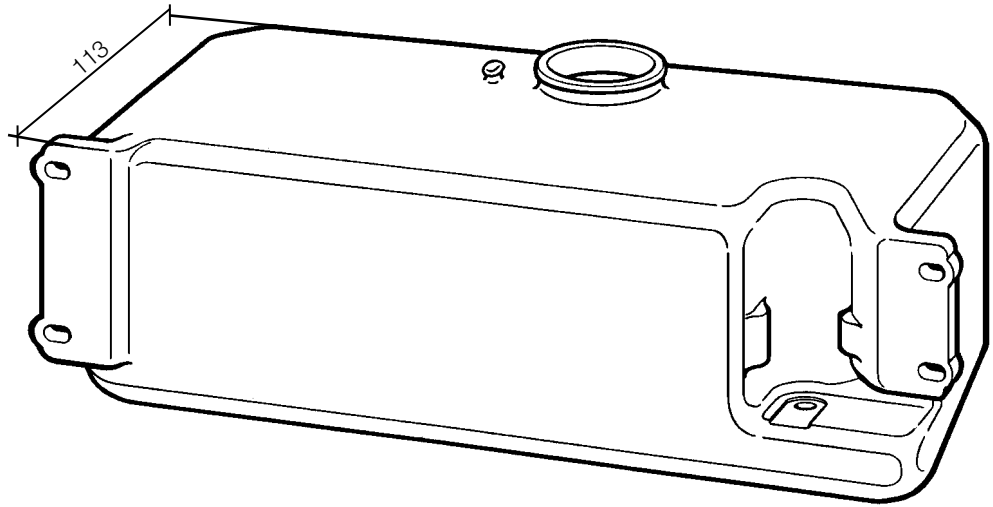

Part Number	Product	Units per pack
X10-246-001-012	VDO Mono Pump 12 V	6
X10-246-001-013	VDO Mono Pump 24 V	6
X10-246-001-014	VDO Dual Pump 12 V	6

Technical data

CONTAINER	
Dimensions	120 x 442 x 113 mm
Volume	4 l
Material	Temperature resistant from -30 °C to +100 °C Weatherproof, ageing resistant
VDO MONO PUMP 12 V	
Pressure	P = 2.2 bar
Flow rate	v = 2.0 l/min.
Current consumption	I max. = 4.5 A
VDO MONO PUMP 24 V	
Pressure	P = 1.8 bar
Flow rate	v = 1.0 l/min.
Current consumption	I max. = 1.2 A
VDO DUAL PUMP 12 V	
Pressure	P = 2.1 bar
Flow rate	v = 2.0 l/min.
Current consumption	I max. = 4.5 A

CONTAINER SYSTEM, 6 LITERS

Comprises:

- 1 container, 6 l
- 1 container cap
- 1 bracket for container
- 1 filter
- 1 Mono Pump
or Dual Pump

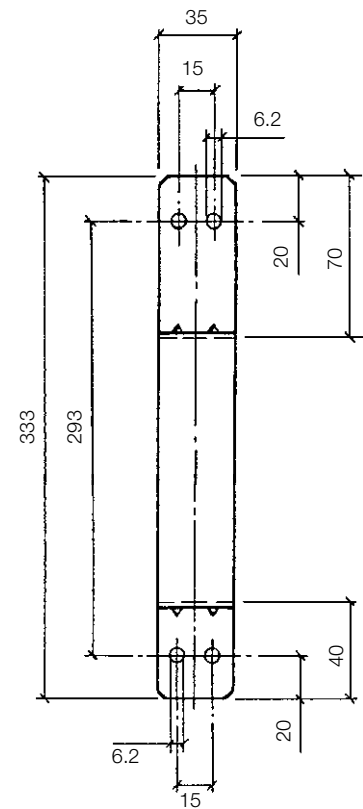
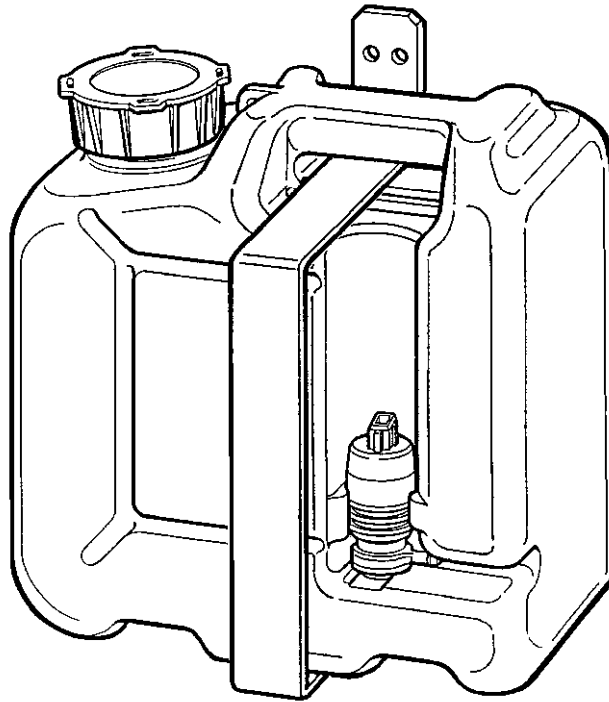

Part Number	Product	Units per pack
X10-246-001-015	VDO Mono Pump 12 V	10
X10-246-001-016	VDO Mono Pump 24 V	10
X10-246-001-017	VDO Dual Pump 12 V	10

Technical data

CONTAINER	
Dimensions	270 x 270 x 130 mm
Volume	6 l
Material	Temperature resistant from -30 °C to +100 °C Weatherproof, ageing resistant
VDO MONO PUMP 12 V	
Pressure	P = 2.2 bar
Flow rate	v = 2.0 l/min.
Current consumption	I max. = 4.5 A
VDO MONO PUMP 24 V	
Pressure	P = 1.8 bar
Flow rate	v = 1.0 l/min.
Current consumption	I max. = 1.2 A
VDO DUAL PUMP 12 V	
Pressure	P = 2.1 bar
Flow rate	v = 2.0 l/min.
Current consumption	I max. = 4.5 A



7. Customer-Specific Solutions

7.1 Control Units and Electronic Network Solutions (ENS)

7.2 Custom Solutions

7.1 Control Units and Electronic Network Solutions (ENS)

Modern vehicles and machines are expected to provide increasingly high levels of efficiency, comfort, and functionality. Our smart onboard electronics system and control unit solutions make it possible to master this challenge.

Control units

We have extensive expertise in the development of control units for specific applications and individual requirements.

Electronic network solutions

Our network solutions for onboard vehicle electronics replace conventional electrics and bulky fixed wiring harnesses. Featuring flexible multiplex architectures, our state-of-the-art networks offer high performance and reliable diagnostics using distributed intelligence techniques. Drivers can access all relevant information at any time via a direct interface. Standard data buses enable easy connection of a variety of components.

Significant system cost reductions

Our onboard electronics system radically reduces the number of cables, connections, plugs, relays, and fuses installed in a vehicle. This significantly increases vehicle reliability and helps lower the cost of wiring, while also reducing the overhead associated with quality checks, documentation, and servicing. Alongside these savings, the costs related to procurement, inventory, and administration can also be trimmed.



Control unit

7.2 Custom Solutions

7.2.1 Panel Design and Build*

From idea to finished panel

The panel forms the basis of each cockpit system and can be supplied in metal or plastic, as required. The complete system comprises the panel, instruments, switches, indicator lamps, and wiring harness and is delivered ready for installation. The instruments used come from our comprehensive VDO instrument range. Our versatile panel solutions can accommodate round or square instruments, digital displays, and audio systems with equal ease.

For us, designing instrument panels is all about meeting specific customer requirements. We work closely with our customers, developing their ideas to create the best possible panel for their needs.



Instrument panel for construction machinery developed to customer specifications

* Only available for series production applications on request



8. Radio and speakers

The RDS Tuner is equipped with a **Worldwide platform**. AM and FM frequency and spacing for Europe/USA/LATAM/ASIA configuration is accessible through radio menu by final user. International vehicle manufacturers do not care anymore what radio to be installed without knowing vehicle final destination.

The upper level models are equipped with **DAB** Tuner for the digital technology of radio, assuring the highest quality of the sound.

Each radio has a **backup memory** system to keep the memory of all the user settings and preset stations when main power is down.

Bluetooth® functionality is now built-in: a truly integrated voice mixing from your mobile phones onto the in-car speakers, and streaming MP3 files from your smartphone.

8.1 Radio

Explore the new generation of radios - the result of an outstanding experience since decades. Vehicle sound systems from VDO have earned a strong reputation within the world of infotainment. This new range applies the harmony of pure aesthetic and sound to all kind of current music sources.

Various impressive models to choose from.

VDO vehicle audio systems are a crowning achievement of our successful continuous product optimization process. Their rugged, reliable construction makes them ideal for every application, from cruising the highway to the tough off-road environment.

The handling of the new VDO radios goes without further explanations by clear design, big buttons and turn keys with grip.

Ease of use was a key priority, alongside high quality. The intuitive interface provides straightforward access to a sophisticated range of functionality and delight by handling a complex world in such a easy way.

Our new vehicle radios are available in different versions, including the top-of-the-range model with Bluetooth and Can-Bus integrated.

Each version is available in both 12 Volts and 24 Volts variant.

New radios

The radio portfolio has been extended by creating two radio ranges. VDO branded and Continental branded. The two ranges are very similar, just the backlighting color and brand logo are different. Continental has an orange display backlighting. VDO has a blue display backlighting.

RDS-Tuner with USB 2.0

TR711U-BU / TR722U-BU
TR7411U-OR / TR7422U-OR

12 / 24 Volts RDS Worldwide tuner, back-up memory for settings and radio presets, USB 2.0 host and AUX input for portable media players.



RDS-Tuner with Bluetooth and USB 2.0

TR712UB-BU / TR723UB-BU
TR7412UB-OR / TR7423UB-OR

12 / 24 Volts RDS Worldwide tuner, back-up memory for settings and radio presets, integrated Bluetooth® handsfree unit and A2DP, USB 2.0 host and AUX input for portable media players.



RDS-Tuner with CD/MP3 and USB 2.0

CD716U-BU / CD726U-BU
CD7416U-OR / CD7426U-OR

12 / 24 Volts RDS Worldwide tuner, back-up memory for settings and radio presets, CD player with MP3/WMA playback, USB 2.0 host and AUX input for portable media players



DAB-Tuner with CD/MP3, Bluetooth and USB 2.0

CDD718UB-BU / CDD728UB-BU
CDD7418UB-OR / CDD7428UB-OR

12 / 24 Volts RDS/DAB/DAB+/DMB Worldwide tuner, back-up memory for settings and radio presets, CD player with MP3/WMA playback, integrated Bluetooth® handsfree unit and A2DP, USB 2.0 host and AUX input for portable media players.



	TR7411U-OR TR711U-BU	TR7422U-OR TR722U-BU	TR7412UB-OR TR712UB-BU	TR7423UB-OR TR723UB-BU
DESIGN:				
Clear, functional design	•	•	•	•
Black matt finished front panel	fixed	fixed	fixed	fixed
LCD, orange/blue illumination	dot	dot	dot	dot
RADIO RECEPTION:				
DAB/DAB+ (digital radio)				
RDS tuner - FM with AF/AM	•	•	•	•
Region setting (EU/USA/LATAM/ASIA)	•	•	•	•
TA Traffic Announcement	•	•	•	•
Autostore (AST)	•	•	•	•
CD PLAYER:				
Deck mechanism				
CD/MP3/WMA				
Scan/Repeat/Track/Random Play, Previous/Next, ID3 tags display				
Electronic Shock Protection (ESP)				
BLUETOOTH:				
Mobile phone functionality HSP/HFP			•	•
Play music from mobile acc. To A2DP/AVRCP			•	•
Internal and external microphone			•	•
USB HOST:				
Front mounted USB connector	standard	standard	standard	standard
USB 1.1/2.0 supported	•	•	•	•
MP3/WMA format supported	•	•	•	•
Max. portable mass storage devices	up to 8 GB	up to 8 GB	up to 8 GB	up to 8 GB
GENERAL:				
Dimensions (W x H x D) in mm	185x55,5x108	185x55,5x108	185x55,5x108	185x55,5x108
Antenna socket (ISO/DIN)	DIN	DIN	DIN	DIN
Operating voltage	12 V	24 V	12 V	24 V
Max. output power	4 x 40 W	4 x 10 W	4 x 40 W	4 x 10 W
Backup memory	•	•	•	•
AUX input	front	front	front	front
Telephone mute (low/high level)	low	low	low	low
Steering wheel remote control	•	•	•	•
Built-in CAN input				

	CD7416U-OR CD716U-BU	CD7426U-OR CD726U-BU	CDD7418UB-OR CDD718UB-BU	CDD7428UB-OR CDD728UB-BU
DESIGN:				
Clear, functional design	•	•	•	•
Black matt finished front panel	fixed	fixed	fixed	fixed
LCD, orange/blue illumination	dot	dot	dot	dot
RADIO RECEPTION:				
DAB/DAB+ (digital radio)			•	•
RDS tuner - FM with AF/AM	•	•	•	•
Region setting (EU/USA/LATAM/ASIA)	•	•	•	•
TA Traffic Announcement	•	•	•	•
Autostore (AST)	•	•	•	•
CD PLAYER:				
Deck mechanism	•	•	•	•
CD/MP3/WMA	•	•	•	•
Scan/Repeat/Track/Random Play, Previous/Next, ID3 tags display	•	•	•	•
Electronic Shock Protection (ESP)	•	•	•	•
BLUETOOTH:				
Mobile phone functionality HSP/HFP			•	•
Play music from mobile acc. To A2DP/AVRCP			•	•
Internal and external microphone			•	•
USB HOST:				
Front mounted USB connector	standard	standard	standard	standard
USB 1.1/2.0 supported	•	•	•	•
MP3/WMA format supported	•	•	•	•
Max. portable mass storage devices	up to 8 GB	up to 8 GB	up to 8 GB	up to 8 GB
GENERAL:				
Dimensions (W x H x D) in mm	185x54,5x162	185x54,5x162	185x54,5x162	185x54,5x162
Antenna socket (ISO/DIN)	DIN	DIN	DIN	DIN
Operating voltage	12 V	24 V	12 V	24 V
Max. output power	4 x 40 W	4 x 10 W	4 x 40 W	4 x 10 W
Backup memory	•	•	•	•
AUX input	rear	rear	rear	rear
Telephone mute (low/high level)	low	low	low	low
Steering wheel remote control	•	•	•	•
Built-in CAN input				



8.2 Loudspeakers

The Loudspeakers VDO return faithfully the pure sound that music deserves. Their power and their sensitivity are compatible with all types of radio.



2 ways loudspeakers

Code	Diameter	Power	Sensitivity
051-018-011	130mm	150W	87dB

Description

- Waterproof loudspeakers 13cm - 2 way , the design specification for permanent use outside.
- Magnets and connections protected against moisture.
- Treatment plastic parts anti - UV , ASA.
- Mounting accessoires in stainless steel.
- Diameter 130mm.
- Tweeter: 36mm Neodymium.
- Nominal Impedance: 4 ohm.
- Maximum Power 150w.
- Nominal Power 30w.
- Frequency Range: 70Hz - 20kHz.
- Performance: 87db.
- Weight: 550gr + 10.
- Protection degree: IP65.
- Resistant to salty water steam (CEI EN 60068-2-11).
- Color: White (RAL9003).



Code	Diameter	Power	Sensitivity
HP1021	100mm	50W(15W nominal)	89dB
HP1321	130mm	60W(15W nominal)	89dB

Description

- Loudspeakers 13cm - 2ways.
- Cone in polipropylene.
- Aluminium coils.
- Mounting accessoires in stainless steel.
- Livery in pairs.



Code	Diameter	Power	Sensitivity
HP1021/B	100mm	50W(15W nominal)	86dB

Description

- Cone in polipropylene.
- Aluminium coils.
- Livery in pairs.
- Bulk Packaging: 30pcs/box.



2 ways marine loudspeakers

Code	Diameter	Power	Sensitivity
HPW1321/16	130mm	60w (15W nominal)	87dB

Description

- Cone in polipropylene.
- Aluminium coils.
- Livery with white grid and fixing screws.
- White Color (RAL 9003).



Loudspeaker grids

Code	Description	Diameter
051-018-001	White grid	130mm
051-018-000	Black round grid for HP 100mm	100mm
XRC-1-96-101	Black sqared grid for HP 100mm	100mm

Description

- Loudspeakers 13cm - 2ways.
- Cone in polipropylene.
- Aluminium coils.
- Mounting accessoires in stainless steel.
- Livery in pairs.



8.3 Accessories

Antennas

Code	Description	Color	Rod	Inclination	Cable length
10-121	AM/FM rigid antenna for roof mount	Black	Fiberglass 375 mm	0° - 70°	2,50 mt
10-123 (TBC)	AM/FM rigid antenna for roof mount	Black	Fiberglass 348 mm	0° - 90°	2,30 mt
10-124	AM/FM flexible antenna for roof mount	Black	Rubber 190 mm	0° - 90°	2,30 mt
10-125E	15dB Amplified AM/FM antenna windscreen	Black	280 mm	-	1,50 mt
2910000088600	14dB Amplified rigid DAB/AM/FM antenna for roof mount	Black	PVC plus metal 405 mm	-	4,50 mt

Cables and Adapters

Code	Description	Cable length
561-060	Extended DIN (male/female plugs) coaxial cable	3500 mm
2910000075300	FAKRA to DIN adapter for passive antenna	
2910000075400	FAKRA to DIN adapter with power for amplified antenna	
413-8070	Cable RCA 3 male outlets/ 3 outlets M	10 m
413-8072	Cable RCA 3 male outlets/ 3 outlets M	1,2 m
413-8075	Cable RCA 3 male/ 3 outlets MA	5 m
413-2155	Cable RCA adapter fem/fem	
413-1RCAC05	RCA video cable 1 male outlet	5 m
413-2RCA015	RCA cable 2 male outlets /2 outlets M	1,5 m
413-2RCA05	RCA cable 2 male outlets /2 outlets M	5 m
413-2RCA15	RCA cable 2 male outlets /2 outlets M	15 m
413-2RCA20	RCA cable 2 male outlets /2 outlets M	20 m
413-3RCA15	Cable RCA 3 male outlets/ 3 outlets M	15 m
413-3RCA20	Cable RCA 3 male outlets/ 3 outlets M	20 m
413-2JRCA05	Audio cable Jack/RCA	5 m
413-2JRCA10	Audio cable Jack/RCA	10 m
413-2JRCA15	Audio cable Jack/RCA	15 m

9. Rearview systems

The VDO Rearview systems are a good choice to increase safety in the workplace and to compensate for the risks associated with the vehicles mobility. VDO offers a wide range of products, which are able to meet all needs.



9.1 Standard Line

Colour Rear View Kit 12/24V



- Applications: Heavy Duty Vehicles Agriculture/ Off-Highway/Special Vehicles.
- Automatic switching of rear view system when rear gear is engaged.
- Accessories and mounting cables included (Connecting cable 20 m).

Part number	Description
A2C59517757	Kit colour camera A2C59517750 + Colour monitor 7" A2C59517754

Monitor



- 7" Colours Wide(16:9) TFT-LCD Monitor 1440 × 234 Pixels.
Mode: Nor./ Mir. and Up/ Down Image Reversing.
With quad version, various visualizations (A2C59517753).
- 10 ~ 32V DC Free Voltage supply.
- 4 camera inputs (A2C59517753).
- 3 camera inputs (A2C59517754).
- 3/4 ch. Trigger function (auto power ON).
- Auto bright: built-in CDS sensor.
- Auto detection of vehicle movement.
- Accepts PAL, NTSC and SECAM formats.
- 6 languages (English, German, Italian, French, Spanish, Japanese) OSD.
- Automatic rear-gear activable distance marker (A2C59517753).
- AV In for VCR, VCD, DVD, DVR.
- Optional button illumination through back lighting LEDs.
- Built-in speaker.
- Rainproof (IP 54).
- Vibration resistant (4G).
- Sun Visor with urethane protection (pat. pend.).

Technical data	
Screen format	7" Wide / 155mm × 89mm
Resolution	1440 (W) × 234(H) mm
Dot Pitch	0.107(W) × 0.370(H)mm
View angle	Up 40° / Down 60° - Left 60° / Right 60°
Input formats	NTSC / PAL / SECAM
Input channels	3-4 cameras / AV Input (opt.)
Supply	DC 10~32V Free Voltage
Current consumption	Max 14 Watt
Operating temperature	from -20°C to +70°C
Storage temperature	from -30°C to +85°C
Dimension	Mm 186(W) × 132(H) × 25(D)
Weight	kg 0.6

Part number	Description	Type	Input	Operating T	Dimension mm (WxHxD)	TV System
A2C59517753	7" Color QUAD Monitor	TFT LCD	4 TLC	-20°C +70°C	186x132x25	PAL/NTSC/SECAM
A2C59517754	7" Color Monitor	TFT LCD	3TLC	-20°C +70°C	186x132x25	PAL/NTSC/SECAM

Rear Cameras



- 1/3" Sensor Sony Super HAD CCD.
- 420 TV lines (270,000 / 320,000 Pixels) / 0 Lux at F2.0 (with LED ON).
- Normal and mirror mode.
- LEDs IR for night vision.
- Auto IRIS lens.
- Audio function.
- 100% Waterproof design (IP68).
- Alluminium diecast housing rustproof and vandalproof.
- Vibration resistant (10G).
- Operating temperature from -30°C to +60°C (A2C59517750).
- Operating temperature from -50 to +60°C (A2C59517749).
- Wide View Angle 150° (120° for A2C59517749).
- Side installation possible (only A2C59517749).
- Heating system built-in.
- Sun shield (only AC59517750).
- Dimension: mm 70(W)x42(H)x55(D) (A2C59517750).
- Dimension: mm 60(W)x55(H)x78.5(D) (A2C59517749).
- Weight: kg 0.3.

Part number	Description	View angle	PAL Res. (pixel)	Operating T	Dimension mm (WxHxD)	IP
A2C59517749	Rear camera, grey case, colour	120°	320K	-50°C +60°C	60 x 55 x 78.5 mm	68
A2C59517750	Rear camera, black case, colour	150°	320K	-30°C +60°C	70 x 42 x 55 mm	68
A2C59517759	Side view camera, grey case, colour	120°	320K	-50°C +60°C	60 x 55 x 78.5 mm	68



Fit for marine use, can be mounted aft for mooring and maneuvering, and for displaying the engine room as well.

- Colour rear camera.
- White case.
- Waterproof (IP68).
- Wide view angle (150°).
- IR LED for night vision.
- Anti-fog system.

Part Number	Description	View angle	PAL Res. (pixel)	Operating T	Dimension mm (WxHxD)	IP
A2C59517756	Rear camera, white case, colour	150°	320K	-30°C +60°C	70 x 42 x 55 mm	68

Accessories

Part Number	Descrizione
A2C59517751	10mt cable with connectors for A2C cameras
A2C59517752	20mt cable with connectors for A2C cameras
A2C59517755	ITA-A2C rearview systems adapter cable
A2C59517761	5mt extension cable for A2C cameras
A2C59517764	50mt extension cable
ITA-C82-ACC-000	18mt extension cable for ITA cameras
ITA-C82-ACC-001	5mt extension cable for ITA cameras



9.2 Pro Line



Colour Rear View Kit 12/24 V

- Applications: Heavy Duty Vehicles Agriculture/ Off-Highway/Special Vehicles.
- Automatic switching of rear view system when Rear gear is engaged.
- Accessories and cables included.

Part number	Description
2910000117500	Kit colour 7" Wireless: camera 2910000119500 + monitor 7" 2910000118600
2910000117400	Kit colour 9" Sensitive: camera 2910000119000 + monitor 9" 2910000118200
2910000117300	Kit colour 7" Waterproof: camera 2910000119000 + monitor 2910000118300
2910000117200	Kit colour 7" Sensitive: camera 2910000119000 + monitor 2910000118100
2910000117100	Kit colour 7" Plus: camera 2910000119000 + monitor 2910000117700
2910000117000	Kit colour 10,1": camera 2910000118700 + monitor 2910000117800
2910000116900	Kit colour 7": camera 2910000118700 + monitor 2910000117700
2910000116800	Kit colour 5": camera 2910000118700 + monitor 2910000117600



Wireless Monitor

- 7" Colours Wide (16:9) TFT-LCD monitor.
- Digital Wireless video reception: 2,4 GHz (2400-2483 MHz), max. 100mt range.
- Mode Normal / Mirror.
- 10 – 32 V DC Free Voltage supply.
- 4 camera inputs.
- 1 Watt built in speaker.
- Automatic rear-gear activation.
- Remote control, display holder incl.
- Detachable Sun Visor.

Technical data	
Screen format	7" Wide
Resolution	800 x 480 pixels
View angle	Up 50° / Down 60° / Left 70° / Right 70°
Brightness	400 cd/m2
Input channels	4 cameras
Power supply	DC 10-32 V Free Voltage
Current consumption	Max. 6 Watt
Operating temperature	from -20°C to +50°C
Storage temperature	from -30°C to +80°C
Dimensions	182 x 122 x 26 mm (WxHxD)

Part number	Description	Type	Input	Operating T	Dimension mm (WxHxD)	TV System
2910000118600	7" Colour Wireless Monitor	TFT LCD	4 TLC	-20°C +50°C	182x122x26	PAL/NTSC



Sensitive Monitor

- 7" / 9" Colours Wide (16:9) TFT-LCD monitor.
- Sensitive buttons.
- LED backlight for buttons.
- Quad model available.
- Mode Normal / Mirror.
- 10 – 32 V DC Free Voltage supply.
- 3 / 4 camera inputs.
- 1 Watt built in speaker.
- Automatic rear-gear activation.
- Waterproof IP69K model available.
- Vibration resistant 7,5 g.
- Remote control, display holder incl.
- Detachable Sun Visor.

Technical data	
Screen format	7" / 9" Wide
Resolution	800 x 480 pixels
View angle	Up 50° / Down 60° / Left 70° / Right 70°
Brightness	400 cd/m2 for 7" version, 350 cd/m2 for 9" version
Input channels	3 cameras (4 cameras in QUAD version)
Power supply	DC 10-32 V Free Voltage
Current consumption	Max. 6 Watt (Max. 25 Watt in QUAD version)
Operating temperature	from -20°C to +70°C
Storage temperature	from -30°C to +80°C

Part number	Description	Type	Input	Operating T	Dimension mm (WxHxD)	TV System
2910000118500	9" Colour Sensitive Quad Monitor	TFT LCD	4 TLC	-20°C +70°C	232x156x82	PAL/NTSC
2910000118400	7" Colour Waterproof Sensitive Quad Monitor	TFT LCD	4 TLC	-20°C +70°C	198x132x76	PAL/NTSC
2910000118300	7" Colour Waterproof Sensitive Monitor	TFT LCD	3 TLC	-20°C +70°C	197x132x69	PAL/NTSC
2910000118200	9" Colour Sensitive Monitor	TFT LCD	3 TLC	-20°C +70°C	232x156x82	PAL/NTSC
2910000118100	7" Colour Sensitive Monitor	TFT LCD	3 TLC	-20°C +70°C	195x128x94	PAL/NTSC

Standard Monitor



- 5" / 7" / 10,1" Colours Wide (16:9) TFT-LCD monitor.
- LED backlight for buttons.
- Quad model available.
- Mode Normal / Mirror.
- 10 – 32 V DC Free Voltage supply.
- 2 / 3 / 4 camera inputs.
- 1 Watt built in speaker.
- Automatic rear-gear activation.
- Vibration resistant 4 g.
- Remote control, display holder incl.
- Detachable Sun Visor.

Technical data	
Screen format	5" / 7" / 10,1" Wide
Resolution	800 x 480 pixels for 5" and 7" versions, 1024x600 for 10,1" version
Brightness	350 cd/m ² for 5" version, 250 cd/m ² for 7" and 10,1" versions
Input channels	2 cameras (4 cameras in QUAD version)
Power supply	DC 10-32 V Free Voltage
Operating temperature	from -20°C to +70°C
Storage temperature	from -30°C to +80°C

Part number	Description	Type	Input	Operating T	Dimension mm (WxHxD)	TV System
2910000118000	10,1" Colour Quad Monitor	TFT LCD	4 TLC	-20°C +70°C	255x170x72	PAL/NTSC
2910000117900	7" Colour Quad Monitor	TFT LCD	4 TLC	-20°C +70°C	180x121x72	PAL/NTSC
2910000117800	10,1" Colour Monitor	TFT LCD	2 TLC	-20°C +70°C	255x170x72	PAL/NTSC
2910000117700	7" Colour Monitor	TFT LCD	2 TLC	-20°C +70°C	180x121x72	PAL/NTSC
2910000117600	5" Colour Monitor	TFT LCD	2 TLC	-20°C +70°C	141x103x25	PAL/NTSC

Wireless Cameras



- Digital Wireless transmission: max. 120mt Range (swiveling antenna).
- Wide view angle 120°.
- 420 TV lines (512x582 pixels).
- 12 LEDs IR for night vision (max. 7mt).
- Sensibility <0,1 Lux.
- DC 12-24V power supply.
- Max. consumption: 300 mA.
- Mirror function.
- Automatic settings.
- Integrated microphone.
- High protection IP69K.
- Vibration resistant 10g.
- Operating T: from -20°C to +70°C.
- Dimensions: mm 87(W)x72(H)x66(D).
- Weight: 330 g.

Part number	Description	View Angle	PAL Res. (pixels)	Operating T	Dimension mm (WxHxD)	IP
2910000119500	Colour Rear camera Wireless, black case	120°	300K	-20°C +70°C	87x72x66	69K



Rear Cameras

- 1/3" CCD colour sensor (1/3" CMOS colour sensor for 2910000118700).
- Wide view angles 120°, 150°.
- 420 TV lines.
- LEDs IR for night vision (max. 10mt).
- Sensibility <0,1 Lux.
- DC 12V power supply (from monitor).
- Max. consumption: 300 mA.
- Mirror function (excl. version 2910000118700).
- Automatic settings.
- Integrated microphone.
- Motorized shutter and integrated heating (only version 2910000118800).
- 100% Waterproof design (IP68, IP69K).
- Vibration resistant 10g (6g for 2910000118700).
- Aluminium diecast housing.
- Operating T: from -20°C to +70°C.
- Weight: 380 g.

Part number	Description	View Angle	PAL Res. (pixels)	Operating T	Dimension mm (WxHxD)	IP
2910000118800	Colour Rear camera, motorized heated, silver cas	150°	300K	-20°C +70°C	87x71x60	69K
2910000119000	Colour Rear camera, Inox silver case	120°	300K	-20°C +70°C	41x72x57	69K
2910000118700	Colour Rear camera, silver case	120°	320K	-20°C +70°C	75x62x59	68



Side Cameras

- Side mounting against blind spots.
- 1/3" CCD Sharp sensor (2910000118900)
1/4" CCD colour sensor (2910000119100).
- Wide view angles 170°, 150°.
- 420 TV lines (512x582 pixels).
- LEDs IR for night vision (max. 10mt).
- Sensibility <0,1 Lux.
- DC 12V power supply (from monitor).
- Max. consumption: 300 mA.
- Mirror function (only 2910000118900).
- 360° adjustable lens (only 2910000119100).
- Automatic settings.
- 100% Waterproof design (IP69K).
- Vibration resistant 10g.
- Alluminium diecast housing ABS support for 2910000118900.
- Operating T: from -20°C to +70°C.
- Weight: 270 g.

Part number	Description	View Angle	PAL Res. (pixels)	Operating T	Dimension mm (WxHxD)	IP
2910000118900	Colour Side camera, mirror, black case	170°	300K	-20°C +70°C	106x78x98	69K
2910000119100	Colour Side camera, adjustable lens, black case	150°	300K	-20°C +70°C	69x57x42	69K



Snap-fit Cameras

- Suitable for mounting into bumpers.
- 1/3" CCD colour sensor.
- 120° view angle.
- 420 TV lines (512x582 pixels).
- 9 LEDs IR for night vision, max. 8mt (only version 2910000119300).
- Sensibility <0,1 Lux.
- DC 12V power supply (from monitor).
- Max. consumption: 200 mA.
- High protection IP67.
- Vibration resistant 10g (6g for 2910000118700).
- Operating T: from -20°C to +70°C.
- Weight: 80 g.

Part number	Description	View Angle	PAL Res. (pixels)	Operating T	Dimension mm (WxHxD)	IP
2910000119200	Colour Snap-fit camera, night vision, black case	120°	300K	-20°C +70°C	49x31, Ø31	67
2910000119300	Colour Snap-fit camera, black case	120°	300K	-20°C +70°C	63x24, Ø31	67



Accessories

Part number	Description
2910000119600	5mt extension cable for all wired products
2910000119700	10mt extension cable for all wired products
2910000119800	20mt extension cable for all wired products
2910000119900	Trailer cable for mounting on trucks, 1 camera input, 5mt monitor cable
2910000120000	Wireless transmitter for one camera, to use each camera with 2910000117500
2910000120100	Wireless receiver for one monitor, to use each monitor with 2910000119500
2910000120200	Kit Wireless transmitter and receiver for one camera and one monitor
2910000120300	Rear sensor kit for camera system: control box, 4 parking sensors

10. Product Solutions and Applications

	CANcockpit	Ocean Link	Centrobase 300/500	Modulcockpit II	Viewline	Instrument panels	Sensors	Fuel systems	Pedals	Actuators	AGB III	Pedal Interface II	Screen washer systems	Audio systems	Marine sensors	Control units and electronic network solutions (ENS)
ON-HIGHWAY																
Cars	•		•		•		•		•	•		•	•	•		
Mobile cranes	•		•	•	•	•	•	•	•	•		•	•	•		•
Buses	•		•	•	•	•	•	•	•	•	•	•	•	•		•
Trucks	•		•	•	•	•	•	•	•	•	•	•	•	•		•
Special-purpose vehicles	•		•	•	•		•	•	•	•	•	•	•	•		
OFF-HIGHWAY																
Construction vehicles	•		•	•	•	•	•	•	•	•	•	•	•	•		
Agricultural vehicles	•		•		•	•	•	•	•	•	•	•	•	•		
Industrial trucks				•	•	•	•	•				•	•	•		
Forestry vehicles	•		•	•	•	•	•	•	•	•	•	•	•	•		
Special-purpose vehicles	•		•	•	•	•	•	•	•	•	•	•	•	•		
LEISURE VEHICLES																
Power sports vehicles								•			•	•				•
Motorcycles							•	•			•	•				
LEISURE BOATS																
Engine-powered and sailing boats		•			•	•	•	•						•	•	
Boat engines		•			•	•	•	•							•	
STATIONARY MACHINERY																
Engines					•	•	•	•		•						
Generators				•	•		•	•				•				
Compressors				•	•		•	•				•				
Engine-powered equipment				•	•		•	•								

Note

Italian Office:

Continental Automotive Trading Italia Srl
Via G. Matteotti, 62
20092 Cinisello Balsamo (MI), Italy
Tel. +39 02356801
Fax +39 02 35680325
vdo.it@continental-corporation.com
www.vdo.it
VDO - A Trademark of the Continental Corporation

Head Quarter:

Continental Automotive GmbH
Sodener Strasse, 9
65824 Schwalbach, Germany
Tel. +49 6196 870
Fax +49 6196 86571

The information provided in this brochure contains only general descriptions or performance characteristics which may not always apply in actual applications in the manner described and/or which can change as a result of the further development of the product. The information contained here is merely a technical description of the product and is especially not intended to guarantee any specific quality or service life. An obligation to provide desired characteristics only exists if this has been expressly agreed in the terms of contract. The right is reserved to alter the delivery options and make technical changes.

Continental Trading GmbH | English © 2013 | Italian Market Edition 2016

The logo consists of the letters 'VDO' in a bold, blue, sans-serif font. The 'V' and 'D' are connected at the top, and the 'O' is a simple circle.